

# peerless-AV™



COMPLETE LINE OF AUDIO VISUAL MOUNTING SOLUTIONS

PRODUCT CATALOG 2012

# TABLE OF CONTENTS

Customer Care.....	pg# 2
Installation Safety and Sales Training.....	pg# 3
Custom Solutions.....	pg# 4

## FLAT PANEL MOUNTS

### Flat Panel Mounts Table of Contents Tab

Find The Perfect Mounting Solution.....	pg# 5
Flat Panel Universal Mount Chart.....	pg# 6-10
Ultra Slim Universal Flat, Tilt, Articulating & Motorized Wall Mounts.....	pg# 11-23
<b>SMARTMOUNT<sup>XT</sup></b> Universal Flat, Tilt & Articulating Wall Mounts.....	pg# 24-32
<b>SmartMount<sup>®</sup></b> Universal Flat, Tilt, Pivot & Articulating Wall Mounts.....	pg# 33-58
Display-Specific Flat & Tilt Wall Mounts.....	pg# 59-60
Peerless PRO Flat, Tilt, Fixed Tilt, Pivot & Articulating Wall Mounts.....	pg# 61-77
Universal Tablet Mounts.....	pg# 78-79
<b>ONEMount<sup>™</sup></b> Modular Wall Mount.....	pg# 80
PLA Series Articulating Wall Arms.....	pg# 81-84
In-wall Mounts.....	pg# 85-87
Rotational Mounts.....	pg# 88
Corner Mounts.....	pg# 89-90
Conversion Kits.....	pg# 91
Ceiling Mounts.....	pg# 92-98
Desktop Mounts.....	pg# 99-111
Stands & Carts.....	pg# 112-125
Outdoor Mounts, Enclosures & Wind Rated Mounts.....	pg# 126-132

## PROJECTOR & WHITEBOARD MOUNTS

### Projector Mounts Table of Contents Tab

Spider <sup>®</sup> Universal Projector Adapter Intro .....	pg# 133
Projector Mount and Accessories Selection Guide .....	pg# 134
Projector Mounts.....	pg# 135-149
Security Projector Mounts.....	pg# 150
Projector Enclosure.....	pg# 151
Extension Columns.....	pg# 152
Short Throw Projector Mounts.....	pg# 153
Whiteboard Mounts.....	pg# 154-155

## AV ACCESSORIES

### AV Accessories Table of Contents Tab

Cables.....	pg# 157-162
Cable Management Channel.....	pg# 163
AV Component Rack Systems.....	pg# 164-165
AV Shelves.....	pg# 166-167
AV Component Shelves.....	pg# 168
AV Component Shelf Accessory Brackets.....	pg# 169
Game Console Security Mounts & Covers.....	pg# 170-171
Speaker Mounts.....	pg# 172-175
Camera Mounts.....	pg# 176

## DIGITAL SIGNAGE

### Digital Signage Table of Contents Tab

Video Wall Mounts.....	pg# 177-180
Digital Menu Board Kit.....	pg# 181
Portable Video Wall Cart.....	pg# 182
Dual Display Ceiling Mounts.....	pg# 183
Media Player Storage Mounts.....	pg# 184

## HOSPITALITY MOUNTS

### Hospitality Mounts Table of Contents Tab

Set Top Box Storage Mounts .....	pg# 185
Pull-out Swivel Wall Mount .....	pg# 186
Desktop Swivel Mounts .....	pg# 187
Display Base Lock-down Security Kits .....	pg# 188

## MOUNTING ACCESSORIES

### Mounting Accessories Table of Contents Tab

Mount Accessories .....	pg# 189
Ceiling Plates & Accessories .....	pg# 190-192
Extensions & Accessories .....	pg# 193-194
Arms & Wall Plates.....	pg# 195
Wall Plates & Hardware.....	pg# 196
In-Wall Accessories Boxes .....	pg# 197
Shelves and Casters.....	pg# 198
Security and Safety.....	pg# 199
Enclosure Accessories.....	pg# 200

Index by Model Number.....	pg# 201-204
Terms & Conditions.....	pg# 205



CALL: 630-375-5100  
800-865-2112



FAX: 630-820-8537  
800-359-6500



E-MAIL:  
info@peerless-av.com



ONLINE:  
www.peerless-av.com

Follow us on





## LOOK FOR THESE SYMBOLS...



Flat Panel Mounts



VESA® Pattern



Mounting Pattern



Distance From Wall



Distance From Ceiling



Height Adjustment



Tilt



Tilt | Swivel | Roll



Landscape to portrait



Projector Mounts



Mounting Pattern



Distance From Ceiling



Distance From Wall



Tilt | Swivel | Roll



Quick Ship Item



Max Load



UL Listed



Made in USA



TUV Rheinland



TUV/GS



RoHS



European Conformity



Seismic Safety



Multiple Boxes



Scan this QR code\* to view a video about Peerless-AV on your Smartphone or tablet, or visit [videos.peerless-av.com](https://videos.peerless-av.com).

\*Download a free QR Reader at your devices' app store.





# CUSTOMER CARE

## PEERLESS-AV™ CUSTOMER CARE

 CALL: 630-375-5100  
800-865-2112

 FAX: 630-820-8537  
800-359-6500

 E-MAIL:  
[info@peerless-av.com](mailto:info@peerless-av.com)

 ONLINE:  
[www.peerless-av.com](http://www.peerless-av.com)

## WHEN YOU INSIST ON PEERLESS-AV™, YOU GET MORE THAN GREAT AUDIO VISUAL SOLUTIONS

At Peerless-AV™ customer service is more than a promise; it's a commitment to excellence. Our Customer Care team sets us apart because we set you apart.

### FIRST-CLASS CUSTOMER CARE

The Peerless-AV results-driven customer care team is first-class. Our commitment to comprehensive and ongoing training provides you with the finest customer service in the industry. Each of our representatives is cross-trained and equipped with full product and technical expertise of the Peerless-AV portfolio, providing you with one-call resolution to your inquiry. Coast-to-coast, from 7 a.m. to 7 p.m. CST, Peerless-AV customer care representatives are here to assist you.

### STATE-OF-THE-ART TECHNOLOGY

Our dedication to service includes providing the latest advances in customer care technology. From online chat support to multi-screen order monitoring and processing, Peerless-AV Customer Care team is fully equipped to serve your needs.

With Electronic Data Interchange (EDI), your network can speak directly to our network, quickly managing your inventory and ordering. The Peerless-AV fulfillment team is dedicated specifically to online orders, ensuring every order is fulfilled promptly and accurately.

### B2B PARTNER PORTAL

The Peerless-AV Partner Portal provides comprehensive order and account information, as well as an easy way to get quick answers to the most common account questions, including order tracking and pricing. Register today to receive your login name and password for 24/7 access to your account.



INTEGRATED  
PARTNER  
PROGRAM

The Peerless-AV Integrated Partner Program rewards reseller sales representatives with great benefits and elite privileges that recognize your value to our organization. Partners are first to receive new product announcements, access to exclusive product lines, priority contact with industry-leading customer service, technical support and engineering services, all delivered in a password-protected website. The features and benefits of the program ensure you are well informed, better educated, and totally dialed-in to Peerless-AV. Contact your Peerless-AV representative for more information on joining the Integrated Partner Program.

**peerless-AV™**



## COMPREHENSIVE INSTALLATION AND SALES TRAINING PROGRAMS TARGET YOUR NEEDS

Our Comprehensive Installation Safety and Sales Training Programs provide you with optimum installation and safety procedures as well as an understanding of how to maximize attachment rates and profits. Training is available at novice, intermediate, and advanced levels, and courses are tailored to your specific needs. You won't find this anywhere else but with Peerless-AV™.

### INSTALLATION SAFETY TRAINING PROGRAM

The Installation Safety Training Program is compliant with standards established for continuing education for system integrators and installers. Accredited by organizations including ICIA, CEDIA and NSCA, this on-site, value-added course demonstrates the importance of proper installation techniques and safety, and addresses efficient methods to reduce the risk of faulty installations. You receive customized, hands-on sessions to fit your installation needs, and detailed leave-behind resources that can be referred to again and again. This course is a must for novice, intermediate or seasoned installation professionals.

### SALES TRAINING PROGRAM

The Sales Training Program focuses on selling strategies for dealers, distributors and retailers to increase attachment rates and profits in the mounting solutions and AV accessories categories. This course, driven by the very latest in market trends, leaves you with a complete understanding of the product benefits, features, and strategic advantages that the carried product assortment allows. This on-site session, a complementary training for Peerless-AV resellers, provides your sales team with a solid understanding of how to sell mounting solutions offered in your portfolio. Your team will get answers to the most commonly asked questions and are provided with resources, such as leave behind materials that will assist with technical information, including mounting hole patterns and other various reference tools, that help increase attachment rates.



**TAKE ADVANTAGE OF  
PEERLESS-AV™ VALUE-ADDED  
TRAINING PROGRAMS TODAY!**

### INSTALLATION SAFETY TRAINING PROGRAM

To reserve your session time for Peerless-AV Installation Safety Training Program call 800-865-2112, Ext. 400 or e-mail [training@peerless-av.com](mailto:training@peerless-av.com)

### SALES TRAINING PROGRAM

To reserve your session time for Peerless-AV Sales Training Program call 800-865-2112, Ext. 420 or e-mail [training@peerless-av.com](mailto:training@peerless-av.com).

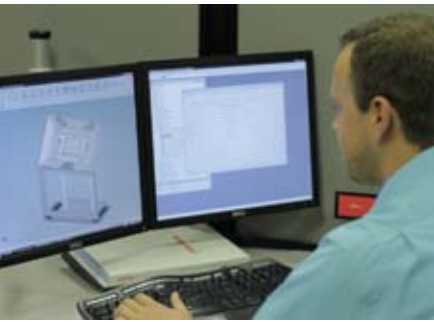

# CUSTOM SOLUTIONS

## PEERLESS-AV™ CUSTOM SOLUTIONS

For more information on developing your custom solution, contact Peerless-AV Customer Care, your Sales Representative or a Project Manager at 800-865-2112 or [info@peerless-av.com](mailto:info@peerless-av.com).

## CUSTOM SOLUTIONS FOR ANY INSTALLATION

Peerless-AV™ is the industry leader in custom AV solutions. In fact, our very first television mount was developed as a 'custom inquiry.' Over the years we've developed innovative audio visual solutions for a wide variety of applications: hotels, stadiums, airports, schools, churches, retail stores, entertainment venues, bars, restaurants and more. Just because it doesn't exist yet, doesn't mean we can't design and manufacture it for you.

### THE PEERLESS-AV CUSTOM TEAM MAKES IT EASY

#### CUSTOM PROJECT MANAGERS

The Peerless-AV Custom Solutions team provides a single point of contact who oversees the project every step of the way, ensuring the timely and ideal solution for your custom project.

#### DEDICATED ENGINEERS

Peerless-AV employs one of the industry's largest and most experienced custom engineering and support staffs, applying skills from a diversity of backgrounds.

#### STATE-OF-THE-ART DESIGN AND PRODUCTION

The Peerless-AV Custom Solutions product development team maintains its own high-tech engineering and manufacturing equipment so you never have to 'wait your turn' as you do with companies that outsource production. Utilizing FEA Simulation software for predictive modeling allows our engineering team to virtually test design performance before prototypes are produced.

Laser CNC machining equipment offers rapid turnaround design prototypes, and faster finished products, making it easy for you to get a custom solution, even on a tough deadline.

### DESIGN. DEVELOP. DEPLOY.

Our D3 process takes you from initial concept to final solution with our experienced and dedicated custom team who works closely with you every step of the way.

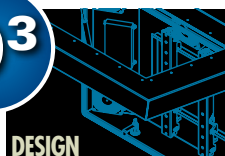

DESIGN

**Contact:** Contact your Sales Representative or Peerless-AV Custom Product Team at 800-865-2112 or [info@peerless-av.com](mailto:info@peerless-av.com).

**Discovery:** Your Custom Project Manager works closely with you to define the particulars of your project.

**Concept Development:** The preliminary concept is developed along with a cost estimate and project schedule.



DEVELOP

**Prototype:** Once the concept is approved, our dedicated custom engineering staff creates a working prototype.

**Prototype Approval:** You evaluate the working prototype.

**Final Product Development:** Dedicated custom engineers finalize the details of your project and schedule resources for the production run.

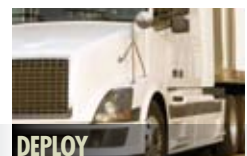

DEPLOY

**Delivery Details:** Final pricing and delivery information is provided.

**Production Run:** Your custom mounting solution is produced in our state-of-the-art 319,000 - square-foot facility. Our entire custom team is under one roof, ensuring your product is produced with the professional quality you expect from Peerless-AV.

**Final Delivery:** Your product is shipped to wherever you need it, anywhere in the world.



## FLAT PANEL MOUNTS TABLE OF CONTENTS

### Ultra Slim Universal Flat, Tilt, Articulating & Motorized Wall Mounts

<b>SUF640P Model</b> Universal Ultra Slim Flat Wall Mount for 23" to 46" Ultra-thin Flat Panel Displays ...	pg# 11
<b>SUF650P Model</b> Universal Ultra Slim Flat Wall Mount for 32" to 56" Ultra-thin Flat Panel Displays ...	pg# 12
<b>SUF660P Model</b> Universal Ultra Slim Flat Wall Mount for 37" to 65" Ultra-thin Flat Panel Displays ..	pg# 13
<b>SUF641 Model</b> Universal Ultra Slim Flat Wall Mount for 23" to 46" Ultra-thin Flat Panel Displays ...	pg# 14
<b>SUF651 Model</b> Universal Ultra Slim Flat Wall Mount for 32" to 56" Ultra-thin Flat Panel Displays ..	pg# 15
<b>SUF661 Model</b> Universal Ultra Slim Flat Wall Mount for 37" to 65" Ultra-thin Flat Panel Displays ..	pg# 16
<b>SUT632P Model</b> Universal Ultra Slim Tilt Wall Mount for 22" to 40" Ultra-thin Flat Panel Displays ...	pg# 17
<b>SUT645P Model</b> Universal Ultra Slim Tilt Wall Mount for 32" to 46" Ultra-thin Flat Panel Displays ...	pg# 18
<b>SUT660P Model</b> Universal Ultra Slim Tilt Wall Mount for 37" to 60" Ultra-thin Flat Panel Displays ...	pg# 19
<b>SUA737/SUA746PU Models</b> Universal Ultra Slim Articulating Wall Arm for 32" to 46" Ultra-thin Flat Panel Displays ...	pg# 20
<b>SUA751PU Model</b> Universal Ultra Slim Articulating Wall Arm for 37" to 55" Ultra-thin Flat Panel Displays ...	pg# 21
<b>SUA761PU Model</b> Universal Ultra Slim Articulating Wall Arm for 42" to 65" Ultra-thin Flat Panel Displays ...	pg# 22
<b>MM746PU Model</b> Ultra Slim Motorized Wall Mount for 23" to 46" Ultra-thin Flat Panel Displays ...	pg# 23

### SMARTMOUNTXT™ Universal Flat, Tilt & Articulating Wall Mounts

<b>SFX645 Models</b> SmartmountXT™ Universal Flat Wall Mount for 32" to 46" Flat Panel Displays .....	pg# 24
<b>SFX650 Models</b> SmartmountXT™ Universal Flat Wall Mount for 32" to 55" Flat Panel Displays .....	pg# 25
<b>SFX660 Models</b> SmartmountXT™ Universal Flat Wall Mount for 46" to 70" Flat Panel Displays .....	pg# 26
<b>STX645 Models</b> SmartmountXT™ Universal Tilt Wall Mount for 32" to 46" Flat Panel Displays .....	pg# 27
<b>STX650 Models</b> SmartmountXT™ Universal Tilt Wall Mount for 32" to 55" Flat Panel Displays .....	pg# 28
<b>STX660 Models</b> SmartmountXT™ Universal Tilt Wall Mount for 46" to 70" Flat Panel Displays .....	pg# 29
<b>SAX755PU Model</b> SmartmountXT™ Articulating Wall Arm for 40" to 52" Flat Panel Displays .....	pg# 30
<b>SAX762PU Model</b> SmartmountXT™ Articulating Wall Arm for 40" to 63" Flat Panel Displays .....	pg# 31
<b>SAX772PU Model</b> SmartmountXT™ Articulating Wall Arm for 50" to 71" Flat Panel Displays .....	pg# 32

### SmartMount® Universal Flat Wall Mounts

<b>SF630 Models</b> SmartMount® Universal Flat Wall Mount for 10" to 24" Flat Panel Displays .....	pg# 33
<b>SF632 Models</b> SmartMount® Universal Flat Wall Mount for 22" to 40" Flat Panel Displays .....	pg# 34
<b>SF640 Models</b> SmartMount® Universal Flat Wall Mount for 23" to 46" Flat Panel Displays .....	pg# 35
<b>SF650 Models</b> SmartMount® Universal Flat Wall Mount for 32" to 56" Flat Panel Displays .....	pg# 36
<b>SF660 Models</b> SmartMount® Universal Flat Wall Mount for 37" to 63" Flat Panel Displays .....	pg# 37
<b>SF670 Models</b> SmartMount® Universal Flat Wall Mount for 42" to 71" Flat Panel Displays .....	pg# 38
<b>SF680 Models</b> SmartMount® Universal Flat Wall Mount for 61" to 102" Flat Panel Displays .....	pg# 39

### SmartMount® Universal Tilt, Pivot & Articulating Wall Mounts

<b>ST630 Models</b> SmartMount® Universal Tilt Wall Mount for 10" to 24" Flat Panel Displays .....	pg# 40
<b>ST632 Models</b> SmartMount® Universal Tilt Wall Mount for 22" to 40" Flat Panel Displays .....	pg# 41
<b>ST635 Models</b> SmartMount® Universal Tilt Wall Mount for 13" to 37" Flat Panel Displays .....	pg# 42
<b>ST640 Models</b> SmartMount® Universal Tilt Wall Mount for 23" to 46" Flat Panel Displays .....	pg# 43
<b>ST650 Models</b> SmartMount® Universal Tilt Wall Mount for 32" to 56" Flat Panel Displays .....	pg# 44
<b>ST660 Models</b> SmartMount® Universal Tilt Wall Mount for 37" to 63" Flat Panel Displays .....	pg# 45
<b>ST670 Models</b> SmartMount® Universal Tilt Wall Mount for 42" to 71" Flat Panel Displays .....	pg# 46
<b>ST680 Models</b> SmartMount® Universal Tilt Wall Mount for 61" to 102" Flat Panel Displays .....	pg# 47
<b>SP730P/SP735P Models</b> SmartMount® Pivot Wall Mounts for 10" to 26" Flat Panel Displays .....	pg# 48
<b>SP740P/SP746PU Models</b> SmartMount® Pivot Wall Mounts for 22" to 46" Flat Panel Displays .....	pg# 49
<b>SP850 Models</b> SmartMount® Pull-out Pivot Wall Mount for 26" to 65" Flat Panel Displays .....	pg# 50
<b>SA730P Models</b> SmartMount® Articulating Wall Arm for 10" to 24" Flat Panel Displays .....	pg# 51
<b>SA735P Models</b> SmartMount® Articulating Wall Arm for 10" to 26" Flat Panel Displays .....	pg# 52
<b>SA740P Models</b> SmartMount® Articulating Wall Arm for 22" to 40" Flat Panel Displays .....	pg# 53
<b>SA746PU Model</b> SmartMount® Articulating Wall Arm for 26" to 46" Flat Panel Displays .....	pg# 54
<b>SA752P(U) Models</b> SmartMount® Articulating Wall Arm for 32" to 52" Flat Panel Displays .....	pg# 55
<b>SA761P(U) Models</b> SmartMount® Articulating Wall Arm for 37" to 60" Flat Panel Displays .....	pg# 56
<b>SA763PU Model</b> SmartMount® Articulating Wall Arm for 37" to 63" Flat Panel Displays .....	pg# 67
<b>SA771P(U) Models</b> SmartMount® Articulating Wall Arm for 37" to 71" Flat Panel Displays .....	pg# 58

### Display-Specific Flat & Tilt Wall Mounts

<b>SF16D/SF24D Models</b> Display-Specific Flat Wall Mount for up to 71" Flat Panel Displays .....	pg# 59
<b>ST16D/ST24D Models</b> Display-Specific Tilt Wall Mount for up to 71" Flat Panel Displays .....	pg# 60

### Peerless PRO Flat & Tilt Wall Mounts

<b>PF630 Model</b> Universal Flat Wall Mount for 10" to 24" Flat Panel Displays .....	pg# 61
<b>PF632 Model</b> Universal Flat Wall Mount for 22" to 40" Flat Panel Displays .....	pg# 62
<b>PF640 Model</b> Universal Flat Wall Mount for 23" to 46" Flat Panel Displays .....	pg# 63
<b>PF660 Model</b> Universal Flat Wall Mount for 37" to 60" Flat Panel Displays .....	pg# 64
<b>PT630 Model</b> Universal Tilt Wall Mount for 10" to 24" Flat Panel Displays .....	pg# 65
<b>PT632 Model</b> Universal Tilt Wall Mount for 22" to 40" Flat Panel Displays .....	pg# 66
<b>PT640 Model</b> Universal Tilt Wall Mount for 23" to 46" Flat Panel Displays .....	pg# 67
<b>PT660 Model</b> Universal Tilt Wall Mount for 37" to 60" Flat Panel Displays .....	pg# 68

continue...

peerless-AV™

CALL: 630-375-5100  
800-865-2112

FAX: 630-820-8537  
800-359-6500

E-MAIL:  
info@peerless-av.com

ONLINE:  
www.peerless-av.com

FLAT PANEL MOUNTS





...continued

**Peerless PRO**

**Fixed Tilt, Pivot & Articulating Wall Mounts**

**PFT640/PFT660 Models**  
Universal Fixed Tilt Wall Mount  
for 23" to 60" Flat Panel Displays.....pg# 69

**PP730 Models**  
Pivot Wall Mount  
for 10" to 24" Flat Panel Displays.....pg# 70

**PP740 Models**  
Pivot Wall Mount  
for 22" to 40" Flat Panel Displays.....pg# 71

**PA730P Models**  
Articulating Wall Arm  
for 10" to 24" Flat Panel Displays.....pg# 72

**PA735F Models**  
Articulating Wall Arm  
for 10" to 26" Flat Panel Displays.....pg# 73

**PA740 Models**  
Articulating Wall Arm  
for 22" to 40" Flat Panel Displays.....pg# 74

**PA746F Model**  
Articulating Wall Arm  
for 26" to 46" Flat Panel Displays.....pg# 75

**PA760 Model**  
Articulating Wall Arm  
for 37" to 60" Flat Panel Displays.....pg# 76

**PS-1/PS-2 Models**  
Swivel and Tilt Wall Mount  
for 32" to 71" Flat Panel Displays.....pg# 77

**Universal Tablet Mounts**

**PTM200 Models**  
Universal Tablet Cradle.....pg# 78

**PTM400 Models**  
Universal Desktop Tablet Mount.....pg# 79

**ONEMount® Modular Wall Mount**

**ONE-TP Models**  
OneMount® Modular Wall Mount  
for 23" to 84" Flat Panel Displays.....pg# 80

**PLA Series**

**Articulating Wall Arms**

**PLA50(-UNL) Models**  
PLA Series Articulating Wall Arm  
for 32" to 65" Flat Panel Displays.....pg# 81

**PLA60(-UNL) Models**  
PLA Series Articulating Wall Arm  
for 37" to 65" Flat Panel Displays.....pg# 82

**PLAV60(-UNL) Models**  
PLA Series Articulating Wall Arm  
with Vertical Adjustment  
for 37" to 65" Flat Panel Displays.....pg# 83

**PLAV70(-UNL) Models**  
PLA Series Articulating Dual Wall Arm  
with Vertical Adjustment  
for 42" to 71" Flat Panel Displays.....pg# 84

**In-wall Mounts**

**Rotational Mounts**

**IM740P Models**  
In-wall Mount  
for 22" to 40" Flat Panel Displays.....pg# 85

**IM760P(U) Models**  
In-wall Mount  
for 32" to 71" Flat Panel Displays.....pg# 86

**IB40 Models**  
In-wall Box  
for up to 40" Flat Panel Displays.....pg# 87

**RM1 Model**  
Rotational Mount Interface  
for up to 71" Flat Panel Displays.....pg# 88

**CM850 Models**  
Corner Mount  
for 32" to 60" Flat Panel Displays.....pg# 89

**CM50/CM60 Models**  
Corner Mount  
for 32" to 60" Flat Panel Displays.....pg# 90

**Conversion Kits**

**Ceiling Mounts**

**PLCK-UNL/ PLCK-1 Models**  
Conversion Kit  
for up to 65" Flat Panel Displays.....pg# 91

**PC930A/B/C Models**  
Ceiling Mount  
for 15" to 24" Flat Panel Displays.....pg# 92

**PC932A/B/C Models**  
Ceiling Mount  
for 15" to 37" Flat Panel Displays.....pg# 93

**LCC-18(-C)/LCC-36(-C) Models**  
Ceiling Mount  
for 13" to 29" Flat Panel Displays.....pg# 94

**PLCM Models**  
Ceiling Mount  
for 32" to 71" Flat Panel Displays.....pg# 95

**MDJ Models**  
Multi-display Ceiling Mounts  
for 32" to 50" Flat Panel Displays.....pg# 96-97

**PLB-1 Model**  
Dual-Display Ceiling Mount  
for 30" to 65" Flat Panel Displays.....pg# 98

**Desktop Mounts**

**PLT-BLK Model**  
Tabletop Stand  
for 32" to 50" Flat Panel Displays.....pg# 99

**LCH-100 Model**  
Height-Adjustable Desktop Mount  
for 10" to 30" Flat Panel Displays.....pg# 100

**LCV-100 Model**  
Height-Adjustable Desktop Mount  
for 10" to 30" Flat Panel Displays.....pg# 101

**LCT100S Model**  
100-Series Desktop Mount  
for 12" to 30" Flat Panel Displays.....pg# 102

**LCT-101 Model**  
Articulating Desktop Mount  
for 10" to 30" Flat Panel Displays.....pg# 103

**LCT-202/LCT-203 Models**  
Dual-Monitor Desktop Mount  
for 10" to 27" Flat Panel Displays.....pg# 104

**LCZ-2F430B Model**  
Dual-Monitor Desktop Mount  
for 20" to 30" Flat Panel Displays.....pg# 105

**LCZ-3F419B Model**  
Triple-Monitor Desktop Mount  
for 14" to 24" Flat Panel Displays.....pg# 106

**LCZ-4F4G30B/LCZ-4F430B Models**  
Quad-Monitor Grommet/Desktop Mount  
for 20" to 30" Flat Panel Displays.....pg# 107

**LCT420A/LCW420A Models**  
420-Series Desktop Mount  
for 12" to 30" Flat Panel Displays.....pg# 108

**LCT620A/LCW620A Models**  
620-Series Desktop Mount  
for 12" to 30" Flat Panel Displays.....pg# 109

**LCT620AD/LCW620AD Models**  
620D-Series Desktop Mount  
for 12" to 30" Flat Panel Displays.....pg# 110

**ACC329 Model** Laptop Cooling Tray  
for most Laptop Computers.....pg# 111

**Stands & Carts**

**SC550/SC550GL Models**  
Floor Cart  
for 42" to 58" Flat Panel Displays.....pg# 112

**SC551GL Model**  
Floor Cart  
for 42" to 55" Flat Panel Displays.....pg# 113

**SS560/SR560 Models**  
Floor Stand/Cart  
for 32" to 65" Flat Panel Displays.....pg# 114

**SC560DPB/DPS/SS560DPB-1/DPS-1 Models**  
Floor Stand/Cart  
for 32" to 65" Flat Panel Displays.....pg# 115

**SS560F Model**  
Floor Stand  
for 32" to 65" Flat Panel Displays.....pg# 116

**SS560DPB/DPS Models**  
Floor Stand  
for 32" to 65" Flat Panel Displays.....pg# 117

**FPZ-600 Model**  
Floor Stand  
for 32" to 70" Flat Panel Displays.....pg# 118

**FPZ-670 Model**  
Floor Stand  
for 50" to 71" Flat Panel Displays.....pg# 119

**SS560FK/SC560FK Models**  
Floor Stand/Cart  
for 32" to 65" Flat Panel Displays.....pg# 120

**SS550P/SGL Models**  
Floor Stand  
for 32" to 65" Flat Panel Displays.....pg# 121

**FPZ-640 Model**  
Floor Stand  
for up to 52" Flat Panel Displays.....pg# 122

**FPZ-646/FPZ655 Models**  
Floor Stand  
for 32" to 55" Flat Panel Displays.....pg# 123

**COL Models**  
Pedestal Mount  
for 32" to 50" Flat Panel Displays.....pg# 124

**LCFS-100 Models**  
Pedestal Stand  
for 10" to 30" Flat Panel Displays.....pg# 125

**Outdoor Mounts**

**Enclosures**

**EPT650 Models**  
Outdoor Universal Tilt Wall Mount  
for 32" and 55" Flat Panel Displays.....pg# 126

**ESA746PU Models**  
Outdoor Articulating Wall Arm  
for 26" and 46" Flat Panel Displays.....pg# 127

**ESA763PU Models**  
Outdoor Articulating Wall Arm  
for 37" and 63" Flat Panel Displays.....pg# 128

**FPE Models**  
Indoor/Outdoor Protective Enclosures  
for 40" to 55" Flat Panel Displays.....pg# 129

**EWMU Models**  
Wind Rated Tilt Wall Mount  
for 32" to 65" Outdoor DFlat Panel Displays ... pg# 130

**ECMU Models**  
Wind Rated Tilt Ceiling Mount  
for 32" to 65" Outdoor DFlat Panel Displays ... pg# 131

**EPMU Models**  
Wind Rated Tilt Pedestal Mount  
for 32" to 65" Outdoor DFlat Panel Displays ... pg# 132

## MountFinder™ @ [www.peerless-av.com](http://www.peerless-av.com)

It is easy to select the perfect mounting solution for any application with the help of the most advanced mount-to-display compatibility resource in the industry – the Peerless-AV MountFinder™. Found at [www.peerless-av.com](http://www.peerless-av.com), this easy-to-use compatibility tool searches thousands of models to find the perfect mounting solution based on your precise needs.

It is simple: answer a few basic questions and you can be assured you just purchased the best mount for the installation.

### WILL THE MOUNT FIT YOUR DISPLAY?

There are three ways to find the mounting solution best suited to the display or projector of choice.

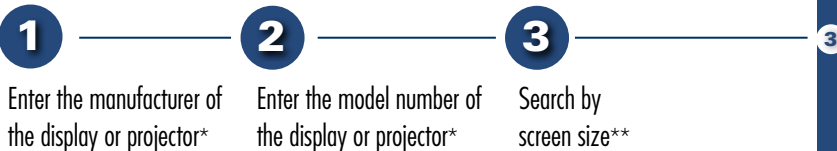

\*This search option will provide you with mounting solutions that passed compatibility tests with the flat panel display.

\*\*It is recommended that you know the manufacturer and model number of the flat panel screen prior to purchasing a mount to ensure 100% compatibility.

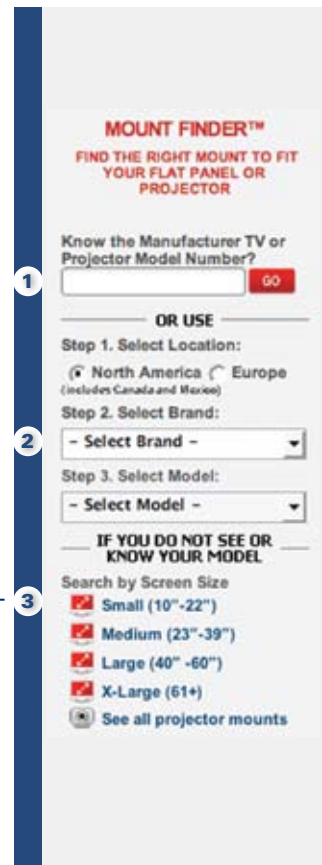

### WHAT ARE THE APPLICATION STYLES AND FUNCTIONALITY REQUIRED FOR YOUR INSTALLATION?

Find the best mounting solution for your application by sorting the compatibility results with the 'Quick Search' selection menu on the right-hand side of your display.

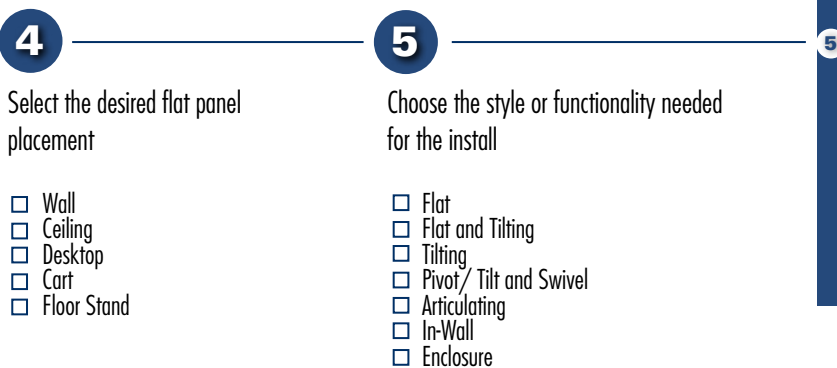

Select the desired flat panel placement

- Wall
- Ceiling
- Desktop
- Cart
- Floor Stand

Choose the style or functionality needed for the install



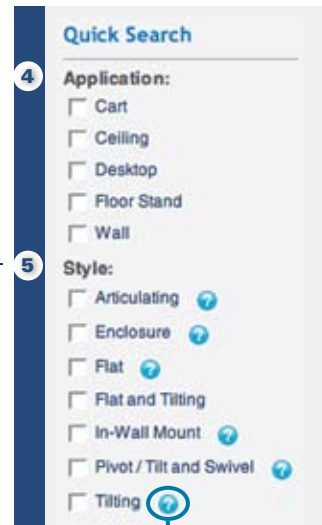

















- Flat
- Flat and Tilting
- Tilting
- Pivot/ Tilt and Swivel
- Articulating
- In-Wall
- Enclosure



### TIP!

By scrolling over the (?) to the side of the style of the mount available you will be provided with a brief description of the styles functionality.

If you completed all of the above steps and are unable to find the mounting solution that fits your needs, just call our expert Customer Care team at 800-865-2112 and we will assist you with identifying the ideal solution.





















Product Type	Flat Panel Display Size Range	Model(s)	Picture	Max Load	Mounting Pattern	Distance From the Wall	Tilt Range	Metal Stud Accessory	Single/ Double Stud Mounting	Catalog Page	
Flat	Ultra Slim	23"-46" for ultra-thin displays only*	SUF640P 	150lb (68kg)	450 x 402mm (17.73"W x 15.82"H)	0.33" (8mm)	N/A	ACC215	Double	11	
		32"-56" for ultra-thin displays only*	SUF650P 	150lb (68kg)	742 x 449mm (29.23"W x 17.67"H)	0.33" (8mm)	N/A	ACC415	Double	12	
		37"-65" for ultra-thin displays only*	SUF660P 	150lb (68kg)	825 x 449mm (32.48"W x 17.67"H)	0.33" (8mm)	N/A	ACC415 / ACC615	Double / Triple	13	
		23"-46" for ultra-thin displays only*	SUF641 	150lb (68kg)	75 to 425mm (in 25mm increments)	0.19" (5mm)	N/A	N/A	Double	14	
		32"-56" for ultra-thin displays only*	SUF651 	150lb (68kg)	150 to 400 & 550 to 700mm (in 25mm increments)	0.19" (5mm)	N/A	N/A	Double	15	
		37"-65" for ultra-thin displays only*	SUF661 	150lb (68kg)	150 to 400 & 550 to 800mm (in 25mm increments)	0.19" (5mm)	N/A	N/A	Double	16	
	SMARTMOUNT™	32"-46"	SFX645(P) 	80lb (36kg)	452 x 433mm (17.79"W x 17.04"H)	1.21" (31mm)	N/A	ACC415	Double	24	
		32"-55"	SFX650(P) 	120lb (54kg)	744 x 433mm (29.29"W x 17.04"H)	1.21" (31mm)	N/A	ACC415	Double	25	
		46"-70"	SFX660(P) 	150lb (68kg)	827 x 433mm (32.54"W x 17.04"H)	1.21" (31mm)	N/A	ACC415	Double	26	
	SmartMount™	10"-24"	SF630(P) 	80lb (36kg)	VESA® 75 and 100mm	0.96" (24mm)	N/A	ACC215	Single	33	
		22"-40"	SF632(P) 	115lb (52kg)	VESA® 75, 100, 200 x 100 and 200 x 200mm	1.02" (26mm)	N/A	ACC215	Single	34	
		23"-46"	SF640(P) 	150lb (68kg)	450 x 329mm (17.73"W x 12.94"H)	1.2" (30mm)	N/A	ACC415	Single / Double	35	
		32"-56"	SF650(P) 	175lb (79kg)	742 x 433mm (29.23"W x 17.05"H)	1.7" (43mm)	N/A	ACC415	Double	36	
		37"-63"	SF660(P) 	200lb (90kg)	825 x 433mm (32.48"W x 17.05"H)	1.25" (32mm)	N/A	ACC415	Double	37	
		42"-71"	SF670(P) 	250lb (113kg)	908 x 503mm (35.75"W x 19.79"H)	1.73" (44mm)	N/A	ACC615	Double / Triple	38	
		61"-102"	SF680(P) 	350lb (158kg)	1111 x 745mm (43.75"W x 29.31"H)	1.83" (46mm)	N/A	ACC615	Triple	39	
		Peerless PRO	10"-24"	PF630 	80lb (36kg)	VESA® 75 and 100mm	0.68" (17mm)	N/A	ACC215	Single	61
			22"-40"	PF632 	115lb (52kg)	VESA® 75, 100, 200 x 100 and 200 x 200mm	0.73" (19mm)	N/A	ACC215	Single	62
23"-46"			PF640 	150lb (68kg)	438 x 329mm (17.25"W x 12.94"H)	1.18" (30mm)	N/A	ACC415	Double	63	
37"-60"	PF660 		200lb (90kg)	730 x 433mm (28.75"W x 17.05"H)	1.68" (43mm)	N/A	ACC415	Double	64		

\* Designed exclusively for use with only ultra-thin displays 2" (50.8mm) deep or less

To verify mount compatibility with any flat panel display or projector model use MountFinder™ at [www.peerless-av.com](http://www.peerless-av.com)





Product Type	Flat Panel Display Size Range	Model(s)	Picture	Max Load	Mounting Pattern	Distance From the Wall	Tilt Range	Metal Stud Accessory	Single/ Double Stud Mounting	Catalog Page			
Ultra Slim	22"-40"	SUT632P for ultra-thin displays only*		60lb (27kg)	VESA® 75, 100, 200 x 100 and 200 x 200mm	0.68"-3.88" (17-98mm)	+17.5°/-5°	ACC215	Single	17			
	32"-46"	SUT645P for ultra-thin displays only*		100lb (45kg)	603 x 408mm (23.75"W x 16.06"H)	0.68"-5.88" (17-149mm)	+17.5°/-5°	ACC415	Double	18			
	37"-60"	SUT660P for ultra-thin displays only*		100lb (45kg)	801 x 408mm (31.53"W x 16.06"H)	0.68"-5.88" (17-149mm)	+17.5°/-5°	ACC615	Triple	19			
	SMARTMOUNT™	32"-46"	STX645(P)(L)		80lb (36kg)	431 x 433mm (16.96"W x 17.04"H)	1.69"-6.65" (43-166mm)	+15°/-5°	ACC415	Double	27		
		32"-55"	STX650(P)(L)		120lb (54kg)	723 x 433mm (28.46"W x 17.04"H)	1.69"-6.55" (43-166mm)	+15°/-5°	ACC415	Double	28		
		46"-70"	STX660(P)(L)		150lb (68kg)	805 x 433mm (31.71"W x 17.04"H)	1.69"-6.55" (43-166mm)	+15°/-5°	ACC415	Double	29		
	Tilt	SmartMount®	10"-24"	ST630(P)		80lb (36kg)	VESA® 75 and 100mm	1.58"-2.23" (40-57mm)	+15°/-5°	ACC215	Single	40	
			22"-40"	ST632(P)		115lb (52kg)	VESA® 75, 100, 200 x 100 and 200 x 200mm	1.66"-2.91" (42-74mm)	+15°/-5°	ACC215	Single	41	
			13"-37"	ST635(P)		125lb (56kg)	245 x 241mm (9.65"W x 9.48"H)	2.63"-4.38" (67-111mm)	+15°/-5°	ACC215	Single	42	
			23"-46"	ST640(P)		150lb (68kg)	458 x 329mm (18.02"W x 12.94"H)	2.63"-4.87" (67-124mm)	+15°/-5°	ACC415	Single / Double	43	
			32"-56"	ST650(P)		175lb (79kg)	750 x 449mm (29.52"W x 17.67"H)	2.63"-5.71" (67-145mm)	+15°/-5°	ACC415	Double	44	
			37"-63"	ST660(P)		200lb (90kg)	832 x 449mm (32.75"W x 17.67"H)	2.63"-5.71" (67-145mm)	+15°/-5°	ACC415	Double	45	
			42"-71"	ST670(P)		250lb (113kg)	915 x 503mm (36.04"W x 19.80"H)	3.04"-6.41" (77-163mm)	+15°/-5°	ACC615	Double / Triple	46	
			61"-102"	ST680(P)		350lb (158kg)	1119 x 745mm (44.04"W x 29.31"H)	3.04"-8.77" (77-223mm)	+15°/-5°	ACC615	Triple	47	
			Peerless PRO	10"-24"	PT630		80lb (36kg)	VESA® 75 and 100mm	2.10"-3.17" (53-81mm)	+15°/-5°	ACC215	Single	65
				22"-40"	PT632		115lb (52kg)	VESA® 75, 100, 200 x 100 and 200 x 200mm	2.18"-3.84" (55-98mm)	+15°/-5°	ACC215	Single	66
	23"-46"	PT640			150lb (68kg)	446 x 329mm (17.54"W x 12.94"H)	2.57"-4.80" (65-122mm)	+15°/-5°	ACC415	Double	67		
	37"-60"	PT660			200lb (90kg)	738 x 449mm (29.04"W x 17.67"H)	2.56"-5.64" (65-143mm)	+15°/-5°	ACC415	Double	68		
23"-46"	PFT640			100lb (46kg)	453 x 329mm (17.85"W x 12.94"H)	1.70"-2.68" (43-68mm)	0°, 2°, 5°, 10°	ACC215	Double	69			
37"-60"	PFT660			175lb (79kg)	828 x 433mm (32.60"W x 17.05"H)	2.00"-2.93" (51-74mm)	0°, 2°, 5°, 10°	ACC415	Double	69			
23"-84"	ONE-TP			250lb (113kg)	1050 x 673mm (41.32"W x 26.48"H)	3.26"-6.93" (83-176mm)	+15°/-5°	ACC415 / ACC615	Double / Triple	80			

\* Designed exclusively for use with only ultra-thin displays 2" (50.8mm) deep or less

To verify mount compatibility with any flat panel display or projector model use MountFinder™ at [www.peerless-av.com](http://www.peerless-av.com)



CALL: 630-375-5100  
800-865-2112



























FAX: 630-820-8537  
800-359-6500



E-MAIL:  
[info@peerless-av.com](mailto:info@peerless-av.com)



























ONLINE:  
[www.peerless-av.com](http://www.peerless-av.com)

Product Type	Flat Panel Display Size Range	Model(s)	Picture	Max Load	Mounting Pattern	Distance From the Wall	Tilt Range	Metal Stud Accessory	Single/Double Stud Mounting	Catalog Page		
Pivot	SmartMount	10"-24"	SP730P		25lb (11kg)	VESA® 75 and 100mm	2.19"-9.31" (56-237mm)	±35°	WSP700/701	Single	48	
		10"-26"	SP735P		25lb (11kg)	200 x 162mm (7.87"W x 6.39"H)	2.71"-10.16" (69-258mm)	±35°	WSP700/701	Single	48	
		22"-40"	SP740P		80lb (36kg)	VESA® 75, 100, 200 x 100 and 200 x 200mm	2.99"-11.80" (76-299mm)	+15°/-5°	WSP700/701	Single	49	
		26"-46"	SP746PU		80lb (36kg)	432 x 408mm (17"W x 16.06"H)	3.74"-12.55" (95-319mm)	+15°/-5°	WSP700/701	Single	49	
		32"-65"	SP850-UNL		150lb (68kg)	729 x 433mm (28.7"W x 17.05"H)	3.40"-11.90" (86-302mm)	0°, 5°, 10°	N/A	Double	50	
	Peerless PRO	10"-24"	PP730		25lb (11kg)	VESA® 75 and 100mm	2.36"-7.01" (60-178mm)	±35°	WSP700/701	Single	70	
		22"-40"	PP740		80lb (36kg)	VESA® 75, 100, 200 x 100 and 200 x 200mm	3.23"-7.88" (82-200mm)	+15°/-5°	WSP700/701	Single	71	
	Articulating	Ultra Slim	32"-46" for Ultra-thin displays only*	SUA737		60lb (27kg)	VESA® 200 x 100 and 200 x 200mm	1.29"-24.17" (33-614mm)	+15°/-5°	N/A	Single	20
			32"-46" for Ultra-thin displays only*	SUA746PU		60lb (27kg)	450 x 402mm (17.73"W x 15.81"H)	1.27"-24.15" (32-613mm)	+15°/-5°	N/A	Single	20
			37"-55" for Ultra-thin displays only*	SUA751PU		100lb (45kg)	825 x 439mm (32.49"W x 17.27"H)	1.34"-24.19" (34-615mm)	+15°/-5°	N/A	Double	21
42"-65" for Ultra-thin displays only*			SUA765PU		100lb (45kg)	854 x 439mm (33.6"W x 17.27"H)	1.24"-28.16" (32-715mm)	+15°/-5°	N/A	Double	22	
SMARTMOUNT XT		40"-52"	SAX755PU		80lb (36kg)	661 x 449mm (26.03"W x 17.69"H)	2.54"-26.41" (65-671mm)	+15°/-5°	N/A	Double	30	
		40"-63"	SAX762PU		110lb (50kg)	661 x 449mm (26.03"W x 17.69"H)	2.60"-26.54" (66-674mm)	+15°/-5°	N/A	Double	31	
		50"-71"	SAX772PU		135lb (61.23kg)	813 x 607mm (32.03"W x 23.91"H)	2.60"-26.54" (66-674mm)	+15°/-5°	N/A	Double	32	
SmartMount		10"-24"	SA730P		25lb (11kg)	VESA® 75 and 100mm	2.19"-16.06" (56-408mm)	±35°	WSP700/701	Single	51	
		10"-26"	SA735P		25lb (11kg)	201 x 159mm (7.93"W x 6.26"H)	3.03"-16.90" (77-429mm)	±35°	WSP700/701	Single	52	
		22"-40"	SA740P		80lb (36kg)	VESA® 75, 100, 200 x 100 and 200 x 200mm	3.35"-20.18" (85-513mm)	+15°/-5°	WSP700/701	Single	53	
		26"-46"	SA746PU		80lb (36kg)	432 x 408mm (17"W x 16.06"H)	4.34"-20.92" (110-531mm)	+15°/-5°	WSP700/701	Single	54	
		32"-52"	SA752PU		90lb (41kg)	689 x 439mm (27.12"W x 17.29"H)	4.43"-27.43" (113-697mm)	+15°/-5°	WSP756	Single	55	
		37"-60"	SA761PU		130lb (59kg)	689 x 439mm (27.12"W x 17.29"H)	4.43"-27.55" (113-700mm)	+15°/-5°	WSP756	Double	56	
		37"-63"	SA763PU		200lb (91kg)	687 x 439mm (27.06"W x 17.29"H)	4.43"-27.55" (113-700mm)	+15°/-5°	WSP756	Double	57	
		37"-71"	SA771PU		200lb (91kg)	827 x 439mm (32.56"W x 17.29"H)	4.43"-27.55" (113-700mm)	+15°/-5°	WSP756	Double	58	
		Peerless PRO	10"-24"	PA730		25lb (11kg)	VESA® 75 and 100mm	2.42"-14.46" (61-367mm)	±35°	WSP700/701	Single	72
10"-26"			PA735F		25lb (11kg)	200 x 159mm (7.87"W x 6.26"H)	3.08"-14.74" (78-374mm)	N/A	WSP700/701	Single	73	

\* Designed exclusively for use with only ultra-thin displays 2" (50.8mm) deep or less

To verify mount compatibility with any flat panel display or projector model use MountFinder™ at [www.peerless-av.com](http://www.peerless-av.com)



Product Type	Flat Panel Display Size Range	Model(s)	Picture	Max Load	Mounting Pattern	Distance From the Wall	Tilt Range	Metal Stud Accessory	Single/ Double Stud Mounting	Catalog Page	
<b>Articulating</b>	<b>Peerless PRO</b>	22"-40"	PA740		80lb (36kg)	VESA® 75, 100, 200 x 100 and 200 x 200mm	3.27"-15.37" (83-390mm)	+15°/-5°	WSP700/701	Single	74
		26"-46"	PA746F		80lb (36kg)	432 x 408mm (17"W x 16.06"H)	2.32"-14.74" (59-374mm)	N/A	WSP700/701	Single	75
		37"-60"	PA760		130lb (59kg)	730 x 433mm (28.75"W x 17.03"H)	5.13"-16.12" (130-409mm)	+15°/-5°	N/A	Double	76
	<b>PLA Series</b>	32"-65"	PLA50-UNL		150lb (68kg)	731 x 433mm (28.76"W x 17.05"H)	5.37"-30.52" (136-775mm)	+10°/-5°	WSP716 / 724	Double	81
		37"-65"	PLA60-UNL		175lb (79kg)	731 x 433mm (28.76"W x 17.04"H)	5.37"-32.37" (136-822mm)	+10°/-5°	WSP716 / 724	Double	82
		37"-65"	PLAV60-UNL		175lb (79kg)	731 x 433mm (28.76"W x 17.04"H)	5.37"-32.37" (136-822mm)	+10°/-5°	WSP716 / 724	Double	83
		42"-65"	PLAV70-UNL		200lb (90kg)	731 x 433mm (28.76"W x 17.05"H)	5.52"-32.52" (140-826mm)	+10°/-5°	WSP716 / 724	Double	84
<b>Motorized</b>	23"-46"	MM746PU <small>for ultra-thin displays only*</small>		110lb (50kg)	VESA® 200 x 200, 300 x 300 and 400 x 400mm	1.375"-8.375" (34.9-212.7mm)	N/A	N/A	Single	23	
<b>In-wall</b>	22"-40"	IM740P		80lb (36kg)	VESA® 75, 100, 200 x 100 and 200 x 200mm	0.08"-12.05" (2-306mm)	+15°/-5°	N/A	Double	85	
	32"-65"	IM760PU		200lb (90kg)	730 x 433mm (28.75"W x 17.05"H)	2.14"-19.88" (54-505mm)	+10°/-5°	ACC615 <small>up to 125lb (62kg)</small>	Double	86	
<b>Corner</b>	32"-60"	CM850		150lb (68kg)	729 x 433mm (28.7"W x 17.05"H)	18.04"-25.79" (458-655mm)	0°, 5°, 10°	N/A	Double	89	
<b>Ceiling</b>	15"-24"	PC930		50lb (22kg)	VESA® 75 and 100mm	N/A	+15°/-5°	N/A	N/A	92	
	15"-37"	PC932		80lb (36kg)	VESA® 100, 200 x 100 and 200 x 200mm	N/A	+15°/-5°	N/A	N/A	93	
	13"-29"	LCC-18/36		40lb (18kg)	VESA® 75 and 100mm	N/A	+20°/-5°	N/A	N/A	94	
	32"-65"	PLCM-UNL-CP		200lb (90kg)	731 x 433mm (28.7"W x 17.05"H)	N/A	+20°	N/A	N/A	95	
<b>Desktop</b>	10"-30"	LCH-100		25lb (11kg)	VESA® 75 and 100mm	5.69" (145mm)	+30°/-50°	N/A	N/A	100	
	10"-30"	LCV-100		25lb (11kg)	VESA® 75 and 100mm	3.00" (76mm)	±30°	N/A	N/A	101	
	12"-30"	LCT100S		20lb (9kg)	VESA® 75 and 100mm	2.30" (58mm)	±40°	N/A	N/A	102	
	10"-30"	LCT-101		25lb (11kg)	VESA® 75 and 100mm	16.05"-23.14" (408-588mm)	±60°	N/A	N/A	103	
	10"-24"	LCT-202		50lb (22kg)	VESA® 75 and 100mm	6.25" (159mm)	±40°	N/A	N/A	104	
	10"-24"	LCT-203		45lb (20kg)	VESA® 75 and 100mm	6.25" (159mm)	N/A	N/A	N/A	104	
	20"-30"	LCZ-2F430B		40lb (18kg)	VESA® 75 and 100mm	5.30" (134mm)	N/A	N/A	N/A	105	
	14"-24"	LCZ-3F419B		40lb (18kg)	VESA® 75 and 100mm	5.30" (134mm)	N/A	N/A	N/A	106	
	20"-30"	LCZ-4F4G30B		40lb (18kg)	VESA® 75 and 100mm	5.30" (134mm)	N/A	N/A	N/A	107	
	20"-30"	LCZ-4F430B		40lb (18kg)	VESA® 75 and 100mm	5.30" (134mm)	N/A	N/A	N/A	107	

\* Designed exclusively for use with only ultra-thin displays 2" (50.8mm) deep or less

To verify mount compatibility with any flat panel display or projector model use MountFinder™ at [www.peerless-av.com](http://www.peerless-av.com)



CALL: 630-375-5100  
800-865-2112



FAX: 630-820-8537  
800-359-6500





























E-MAIL: [info@peerless-av.com](mailto:info@peerless-av.com)



ONLINE: [www.peerless-av.com](http://www.peerless-av.com)



Product Type	Flat Panel Display Size Range	Models	Picture	Max Load	Mounting Pattern	Distance From the Wall / Base	Tilt Range	Metal Stud Accessory	Single/ Double Stud Mounting	Catalog Page
Desktop	12"-30"	LCT420A		20lb (9kg)	VESA® 75 and 100mm	19.40" (493mm)	+80°/-10° monitor ±45° arm	N/A	N/A	108
	12"-30"	LCW420A		20lb (9kg)	VESA® 75 and 100mm	19.40" (493mm)	+80°/-10° monitor ±45° arm	N/A	N/A	108
	12"-30"	LCT620A		20lb (9kg)	VESA® 75 and 100mm	24.76" (629mm)	+80°/-10° monitor ±45° arm	N/A	N/A	109
	12"-30"	LCW620A		20lb (9kg)	VESA® 75 and 100mm	24.76" (629mm)	+80°/-10° monitor ±45° arm	N/A	N/A	109
	12"-30"	LCT620AD		40lb (18kg)	VESA® 75 and 100mm	24.76" (629mm)	+80°/-10° monitor ±45° arm	N/A	N/A	110
	12"-30"	LCW620AD		40lb (18kg)	VESA® 75 and 100mm	24.76" (629mm)	+80°/-10° monitor ±45° arm	N/A	N/A	110
Stands	32"-65"	SS550P		250lb (113kg)	729 x 433mm (28.70"W x 17.05"H)	N/A	+5°/-2°	N/A	N/A	121
	32"-65"	SS560M/G		250lb (113kg)	729 x 433mm (28.70"W x 17.05"H)	N/A	+5°/-2°	N/A	N/A	114
	32"-65"	SS560DPB-1/DPS-1		150lb (68kg)	VESA® 200 and 300mm	N/A	+5°/-2°	N/A	N/A	115
	32"-65"	SS560F		160lb (72.5kg)	VESA® 200 and 300mm	N/A	+5°/-2°	N/A	N/A	116
	32"-65"	SS560DPB/DPS		160lb (72.5kg)	VESA® 200 and 300mm	N/A	+5°/-2°	N/A	N/A	117
	32"-70"	FPZ-600		200lb (90kg) per display	VESA® 100, 200 x 100 and 200 x 200mm	N/A	N/A	N/A	N/A	118
	50"-71"	FPZ-670		200lb (90kg) per display	VESA® 100, 200 x 100 and 200 x 200mm	N/A	N/A	N/A	N/A	119
	up to 55"	FPZ-640		110lb (49kg)	VESA® 75, 100, 200 x 100 and 200 x 200mm	N/A	N/A	N/A	N/A	122
	32"-46"	FPZ-646		100lb (45kg)	438 x 329mm (17.25"W x 12.94"H)	N/A	N/A	N/A	N/A	123
	37"-55"	FPZ-655		100lb (45kg)	730 x 433mm (28.30"W x 15.07"H)	N/A	N/A	N/A	N/A	123
	32"-65"	SS560FK		150lb (68kg)	729 x 433mm (28.70"W x 17.05"H)	N/A	+30°	N/A	N/A	120
	10"-30"	LCFS-100		25lb (11kg) freestanding 40lb (18kg) bolted down	VESA® 75 and 100mm	N/A	N/A	N/A	N/A	125
Carts	42"-58"	SC550		150lb (68kg)	720 x 400mm (28.75"W x 17.04"H)	N/A	+15°/-5°	N/A	N/A	112
	42"-58"	SC550-GL		150lb (68kg)	720 x 400mm (28.30"W x 15.07"H)	N/A	+15°/-5°	N/A	N/A	112
	42"-55"	SC551-GL		91lb (41kg)	720 x 400mm (28.30"W x 15.07"H)	N/A	+15°/-5°	N/A	N/A	113
	32"-65"	SR560M/G		250lb (113kg)	729 x 433mm (28.70"W x 17.05"H)	N/A	+5°/-2°	N/A	N/A	114
	32"-65"	SC560DPB/DPS		150lb (68kg)	VESA® 200 and 300mm	N/A	+5°/-2°	N/A	N/A	115
	32"-65"	SC560FK		150lb (68kg)	729 x 433mm (28.70"W x 17.05"H)	N/A	+30°	N/A	N/A	120
Tablets	N/A	PTM200		5lb (2.27kg)	VESA® 75 x 75mm	N/A	N/A	N/A	N/A	78
	N/A	PTM400		5lb (2.27kg)	N/A	N/A	±30°	N/A	N/A	79

To verify mount compatibility with any flat panel display or projector model use MountFinder™ at [www.peerless-av.com](http://www.peerless-av.com)



# Universal Ultra Slim Flat Wall Mount

For 23" to 46" Ultra-thin Flat Panel Displays

1. Ultra slim design holds displays only 0.33" (8mm) from the wall
2. Industrial strength Velcro® latching system holds display in place against the wall plate preventing accidental bump-off or horizontal adjustment
3. Easy three-step installation, mount the wall plate, attach display adapters to display, hang display
4. Horizontal display adjustment up to 6" (152mm) for centering display on wall
5. Universal display adapters easily hook onto wall plate for fast installation
6. Fits displays with mounting hole patterns up to 450 x 402mm (17.73"W x 15.82"H)



### Display Mounting Requirements

1. Designed for use with displays that are less than 2" (50.8mm) deep.
2. The depth of this mount (0.33" (8mm)) may not provide sufficient space for proper ventilation on some displays. Refer to the manufacturer's requirements for mounting the display before installation.
3. The display must have a flat mounting surface, or mounting holes need to be on the furthest back surface of the display.
4. Input/output connection must be properly orientated to accommodate mounting 0.33" (8mm) from the wall.

Patented

For expanded product information and technical data visit [www.peerless-av.com](http://www.peerless-av.com)

### TECHNICAL DRAWINGS

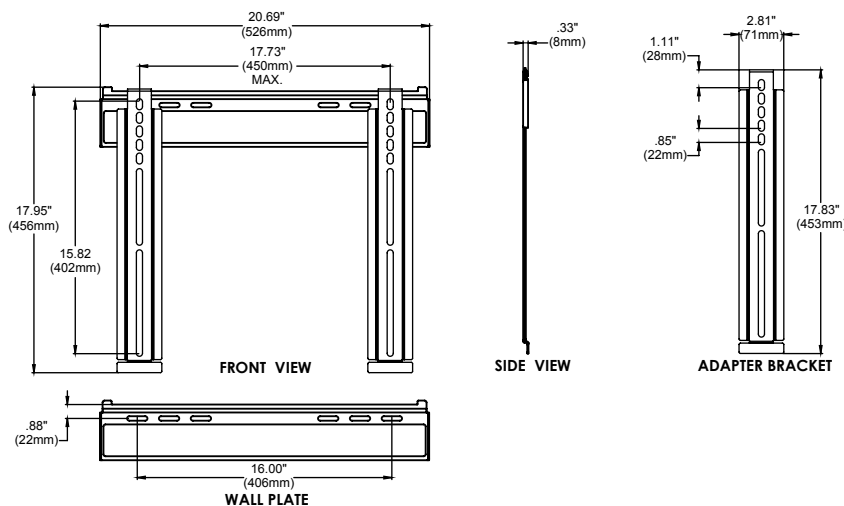

To verify mount compatibility with any flat panel display or projector model use MountFinder™ at [www.peerless-av.com](http://www.peerless-av.com)

### MODELS

#### Universal Models:

Includes standard hardware (hex or Phillips) for attaching display to mount

**SUF640P\*** Gloss black

\* Designed for use with displays that are less than 2" (50.8mm) deep

### DISPLAY ADAPTER



#### Mounting Pattern

Universal Models: 450 x 402mm (17.73"W x 15.82"H)

Many flat panel displays have mounting hole patterns larger than dimensions above. Use MountFinder™ to verify mount compatibility.



#### VESA® Pattern

Universal Models: Up to 400 x 400mm

### SPECIFICATIONS



#### Distance from Wall

0.33" (8mm)



#### Max Load

150lb (68kg)

#### Product Dimensions (W x H x D)

20.69" x 17.95" x 0.33" (526 x 456 x 8mm)

#### Mounting Surfaces

Wood stud, concrete, cinder block and metal stud (Metal stud accessory required)

#### Ship Weight

4.7lb (2.13kg)

### CERTIFICATIONS



### ACCESSORIES



**ACC215:**  
2-pack Metal Stud Fastener Kit ..... pg# 196



**ACC952:**  
Above Display SUF Security Lock Accessory ..... pg# 199



**IBA2(-W), IBA2AC(-W):**  
Recessed Cable Management and Power Storage Accessory Box ..... pg# 197



**IBA3(-W), IBA3AC(-W):**  
Recessed Cable Management and Power Storage Accessory Box ..... pg# 197



**IBA4-W:**  
Easy Mount Recessed Low Voltage Cable Plate ..... pg# 197



**IBA5-W:**  
Recessed Low Voltage Media Plate with Duplex Surge Suppressor ..... pg# 197

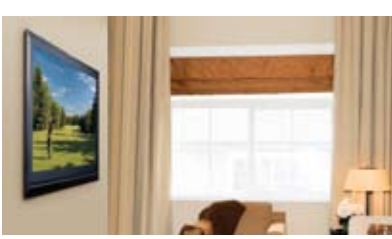

# Universal Ultra Slim Flat Wall Mount

For 32" to 56" Ultra-thin Flat Panel Displays

## MODELS

### Universal Models:

Includes standard hardware (hex or Phillips) for attaching display to mount

**SUF650P\*** Glass black

\* Designed for use with displays that are less than 2" (50.8mm) deep

## DISPLAY ADAPTER

### Mounting Pattern

Universal Models: 742 x 449mm  
(29.23"W x 17.67"H)

### VESA® Pattern

Universal Models: Up to 600 x 400mm

## SPECIFICATIONS

### Distance from Wall

0.33" (8mm)

### Max Load

150lb (68kg)

### Product Dimensions (W x H x D)

32.19" x 21.80" x 0.33"  
(818 x 554 x 8mm)

### Mounting Surfaces

Wood stud, concrete, cinder block and metal stud  
(Metal stud accessory required)

### Ship Weight

7.6lb (3.44kg)

## CERTIFICATIONS



## ACCESSORIES



**ACC415:**  
4-pack Metal Stud  
Fastener Kit ..... pg# 196



**ACC952:**  
Above Display SUF Security  
Lock Accessory ..... pg# 199



**IBA2(-W), IBA2AC(-W):**  
Recessed Cable  
Management and Power  
Storage Accessory Box ..... pg# 197



**IBA3(-W), IBA3AC(-W):**  
Recessed Cable  
Management and Power  
Storage Accessory Box ..... pg# 197



**IBA4-W:**  
Easy Mount Recessed  
Low Voltage Cable Plate ..... pg# 197

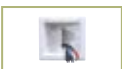

**IBA5-W:**  
Recessed Low Voltage  
Media Plate with Duplex  
Surge Suppressor ..... pg# 197

1. Ultra slim design holds displays only 0.33" (8mm) from the wall
2. Industrial strength Velcro® latching system holds display in place against the wall plate preventing accidental bump-off or horizontal adjustment
3. Easy three-step installation, mount the wall plate, attach display adapters to display, hang display
4. Horizontal display adjustment up to 8" (203mm) for centering display on wall
5. Universal display adapters easily hook onto wall plate for fast installation
6. Fits displays with mounting hole patterns up to 742 x 449mm (29.23"W x 17.67"H)



### Display Mounting Requirements

1. Designed for use with displays that are less than 2" (50.8mm) deep.
2. The depth of this mount (0.33" (8mm)) may not provide sufficient space for proper ventilation on some displays. Refer to the manufacturer's requirements for mounting the display before installation.
3. The display must have a flat mounting surface, or mounting holes need to be on the furthest back surface of the display.
4. Input/output connection must be properly orientated to accommodate mounting 0.33" (8mm) from the wall.

Patented

## TECHNICAL DRAWINGS

For expanded product information and technical data visit [www.peerless-av.com](http://www.peerless-av.com)

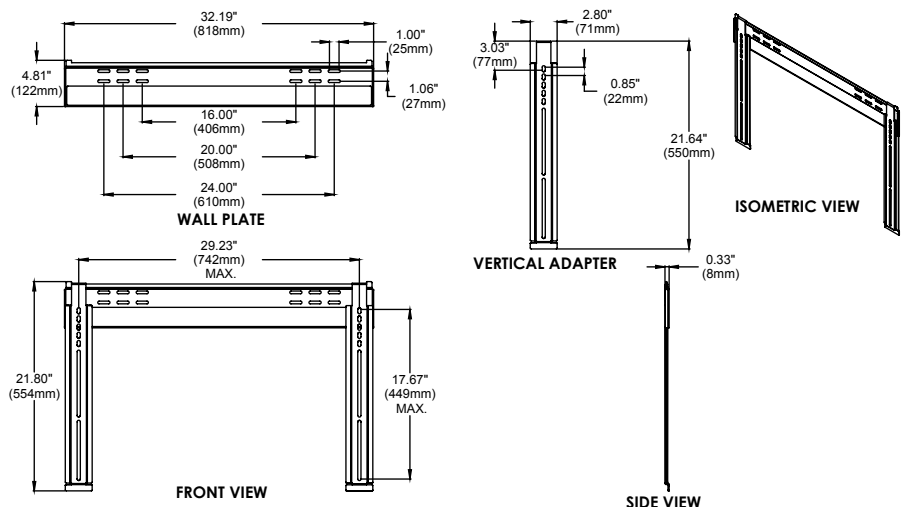



# Universal Ultra Slim Flat Wall Mount

For 37" to 65" Ultra-thin Flat Panel Displays

1. Ultra slim design holds displays only 0.33" (8mm) from the wall
2. Industrial strength Velcro® latching system holds display in place against the wall plate preventing accidental bump-off or horizontal adjustment
3. Easy three-step installation, mount the wall plate, attach display adapters to display, hang display
4. Horizontal display adjustment up to 8" (203mm) for centering display on wall
5. Universal display adapters easily hook onto wall plate for fast installation
6. Fits displays with mounting hole patterns up to 825 x 449mm (32.48"W x 17.67"H)



## Display Mounting Requirements

1. Designed for use with displays that are less than 2" (50.8mm) deep.
2. The depth of this mount (0.33" (8mm)) may not provide sufficient space for proper ventilation on some displays. Refer to the manufacturer's requirements for mounting the display before installation.
3. The display must have a flat mounting surface, or mounting holes need to be on the furthest back surface of the display.
4. Input/output connection must be properly orientated to accommodate mounting 0.33" (8mm) from the wall.

Patented

For expanded product information and technical data visit [www.peerless-av.com](http://www.peerless-av.com)

## TECHNICAL DRAWINGS

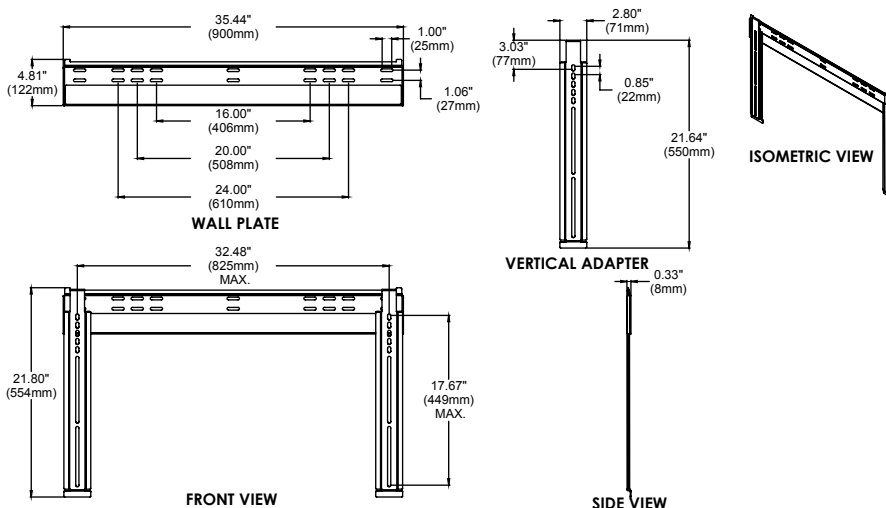

FLAT PANEL MOUNTS

## MODELS

### Universal Models:

Includes standard hardware (hex or Phillips) for attaching display to mount

**SUF660P\*** Gloss black

\* Designed for use with displays that are less than 2" (50.8mm) deep

## DISPLAY ADAPTER



### Mounting Pattern

Universal Models: 825 x 449mm (32.48"W x 17.67"H)



### VESA® Pattern

Universal Models: Up to 800 x 400mm

## SPECIFICATIONS



### Distance from Wall

0.33" (8mm)



### Max Load

150lb (68kg)

### Product Dimensions (W x H x D)

35.44" x 21.80" x 0.33" (900 x 554 x 8mm)

### Mounting Surfaces

Wood stud, concrete, cinder block and metal stud (Metal stud accessory required)

### Ship Weight

7.8lb (3.53kg)

## CERTIFICATIONS



## ACCESSORIES



**ACC415:**  
4-pack Metal Stud Fastener Kit ..... pg# 196



**ACC615:**  
6-pack Metal Stud Fastener Kit ..... pg# 196



**ACC952:**  
Above Display SUF Security Lock Accessory ..... pg# 199



**IBA2(-W), IBA2AC(-W):**  
Recessed Cable Management and Power Storage Accessory Box ..... pg# 197



**IBA3(-W), IBA3AC(-W):**  
Recessed Cable Management and Power Storage Accessory Box ..... pg# 197



**IBA4-W:**  
Easy Mount Recessed Low Voltage Cable Plate ..... pg# 197

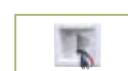

**IBA5-W:**  
Recessed Low Voltage Media Plate with Duplex Surge Suppressor ..... pg# 197

To verify mount compatibility with any flat panel display or projector model use MountFinder™ at [www.peerless-av.com](http://www.peerless-av.com)



# Universal Ultra Slim Flat Wall Mount

For 23" to 46" Ultra-thin Flat Panel Displays

## MODELS

### Universal Models:

Includes standard hardware (hex or Phillips) for attaching display to mount

**SUF641\*** Glass black

\* Designed for use with displays that are less than 2" (50.8mm) deep

## DISPLAY ADAPTER

### VESA® Pattern

Universal Models: 75 to 425mm (in 25mm increments)

## SPECIFICATIONS

### Distance from Wall

0.19" (5mm)

### Max Load

150lb (68kg)

### Product Dimensions (W x H x D)

20.00" x 5.50" x 0.19"  
(508 x 140 x 5mm)

### Mounting Surfaces

Wood stud, concrete and cinder block

### Ship Weight

4lb (1.8kg)

## CERTIFICATIONS



## ACCESSORIES



**ACC952:**  
Above Display SUF Security Lock Accessory ..... pg# 199



**IBA2(-W), IBA2AC(-W):**  
Recessed Cable Management and Power Storage Accessory Box ..... pg# 197



**IBA3(-W), IBA3AC(-W):**  
Recessed Cable Management and Power Storage Accessory Box ..... pg# 197



**IBA4-W:**  
Easy Mount Recessed Low Voltage Cable Plate ..... pg# 197



**IBA5-W:**  
Recessed Low Voltage Media Plate with Duplex Surge Suppressor ..... pg# 197

1. Ultra slim design holds displays only 0.19" (5mm) from the wall
2. Locking arm holds flat panel display in place and prevents accidental bump-offs and unwanted horizontal adjustments
3. Theft resistant security screw on locking arm
4. Easy three-step installation, mount the wall plate, hang the flat panel display and insert the locking arm
5. Fits displays with horizontal mounting hole patterns from 75 to 425mm (in 25mm increments)

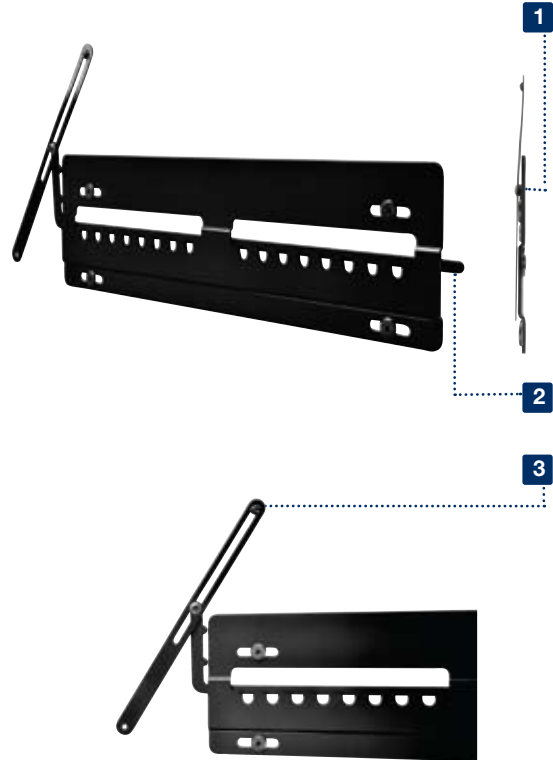

### Display Mounting Requirements

1. Designed for use with displays that are less than 2" (50.8mm) deep.
2. The depth of this mount (0.19" (5mm)) may not provide sufficient space for proper ventilation on some displays. Refer to the manufacturer's requirements for mounting the display before installation.
3. The display must have a flat mounting surface, or mounting holes need to be on the furthest back surface of the display.
4. Input/output connection must be properly orientated to accommodate mounting 0.19" (5mm) from the wall.

Patented

## TECHNICAL DRAWINGS

For expanded product information and technical data visit [www.peerless-av.com](http://www.peerless-av.com)

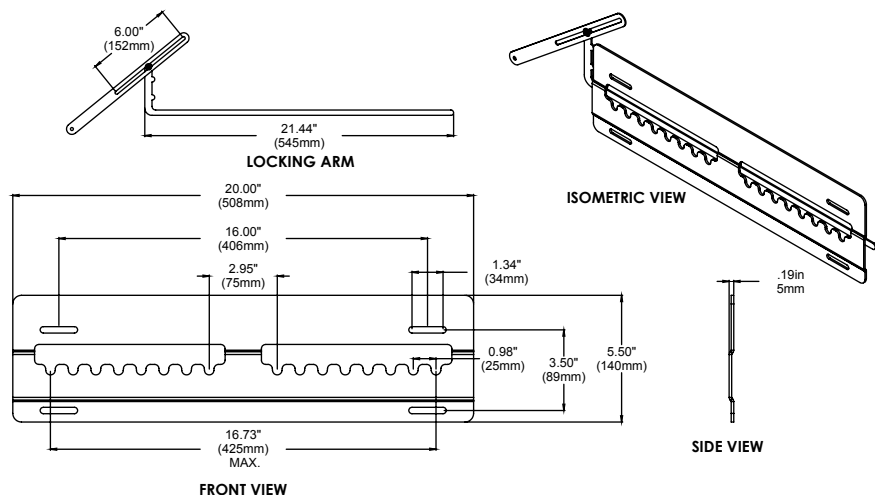

To verify mount compatibility with any flat panel display or projector model use MountFinder™ at [www.peerless-av.com](http://www.peerless-av.com)



CALL: 630-375-5100  
800-865-2112



FAX: 630-820-8537  
800-359-6500



E-MAIL:  
[info@peerless-av.com](mailto:info@peerless-av.com)



ONLINE:  
[www.peerless-av.com](http://www.peerless-av.com)

# Universal Ultra Slim Flat Wall Mount

For 32" to 56" Ultra-thin Flat Panel Displays

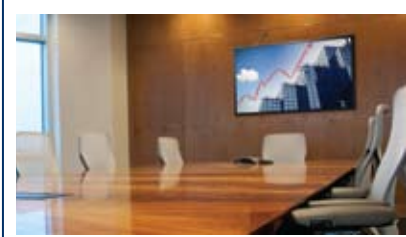

FLAT PANEL MOUNTS

1. Ultra slim design holds displays only 0.19" (5mm) from the wall
2. Locking arm holds flat panel display in place and prevents accidental bump-offs and unwanted horizontal adjustments
3. Theft resistant security screw on locking arm
4. Easy three-step installation, mount the wall plate, hang the flat panel display and insert the locking arm
5. Fits displays with horizontal mounting hole patterns from 150 to 400mm and 550 to 700mm (in 25mm increments)

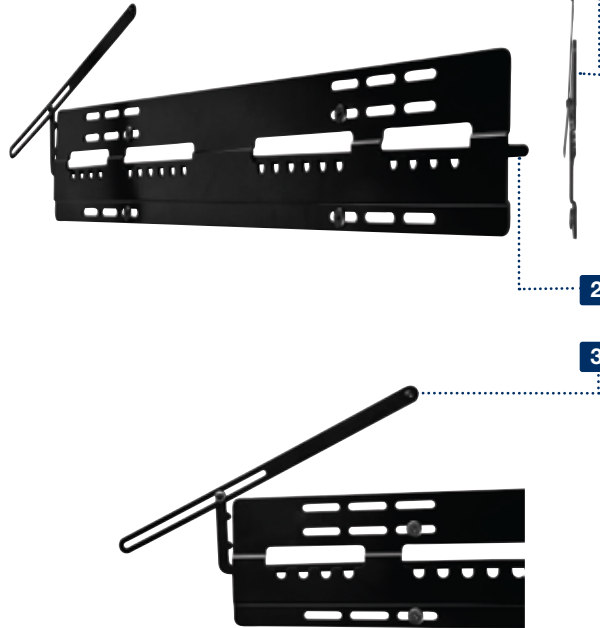

## Display Mounting Requirements

1. Designed for use with displays that are less than 2" (50.8mm) deep.
2. The depth of this mount (0.19" (5mm)) may not provide sufficient space for proper ventilation on some displays. Refer to the manufacturer's requirements for mounting the display before installation.
3. The display must have a flat mounting surface, or mounting holes need to be on the furthest back surface of the display.
4. Input/output connection must be properly orientated to accommodate mounting 0.19" (5mm) from the wall.

Patented

For expanded product information and technical data visit [www.peerless-av.com](http://www.peerless-av.com)

## TECHNICAL DRAWINGS

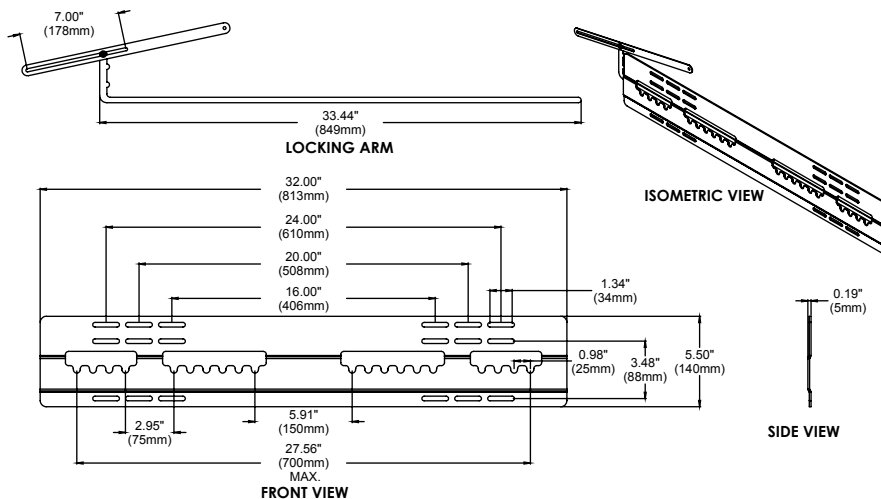

## MODELS

### Universal Models:

Includes standard hardware (hex or Phillips) for attaching display to mount

**SUF651\*** Gloss black

\* Designed for use with displays that are less than 2" (50.8mm) deep

## DISPLAY ADAPTER



### VESA® Pattern

Universal Models: 150 to 400 and 550 to 700mm (in 25mm increments)

## SPECIFICATIONS



### Distance from Wall

0.19" (5mm)



### Max Load

150lb (68kg)

### Product Dimensions (W x H x D)

32.00" x 5.50" x 0.19" (813 x 140 x 5mm)

### Mounting Surfaces

Wood stud, concrete and cinder block

### Ship Weight

5.8lb (2.61kg)

## CERTIFICATIONS



## ACCESSORIES



**ACC952:**  
Above Display SUF Security Lock Accessory ..... pg# 199



**IBA2(-W), IBA2AC(-W):**  
Recessed Cable Management and Power Storage Accessory Box ..... pg# 197



**IBA3(-W), IBA3AC(-W):**  
Recessed Cable Management and Power Storage Accessory Box ..... pg# 197



**IBA4-W:**  
Easy Mount Recessed Low Voltage Cable Plate ..... pg# 197



**IBA5-W:**  
Recessed Low Voltage Media Plate with Duplex Surge Suppressor ..... pg# 197

To verify mount compatibility with any flat panel display or projector model use MountFinder™ at [www.peerless-av.com](http://www.peerless-av.com)



CALL: 630-375-5100  
800-865-2112



FAX: 630-820-8537  
800-359-6500



E-MAIL:  
[info@peerless-av.com](mailto:info@peerless-av.com)



ONLINE:  
[www.peerless-av.com](http://www.peerless-av.com)

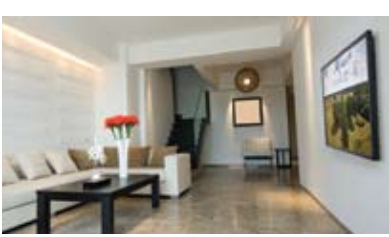

# Universal Ultra Slim Flat Wall Mount

For 37" to 65" Ultra-thin Flat Panel Displays

## MODELS

### Universal Models:

Includes standard hardware (hex or Phillips) for attaching display to mount

**SUF661\*** Glass black

\* Designed for use with displays that are less than 2" (50.8mm) deep

## DISPLAY ADAPTER

### VESA® Pattern

Universal Models: 150 to 400 and 550 to 800mm (in 25mm increments)

## SPECIFICATIONS

### Distance from Wall

0.19" (5mm)

### Max Load

150lb (68kg)

### Product Dimensions (W x H x D)

35.25" x 5.50" x 0.19"  
(895 x 140 x 5mm)

### Mounting Surfaces

Wood stud, concrete and cinder block

### Ship Weight

6.1lb (2.75kg)

## CERTIFICATIONS



## ACCESSORIES



**ACC952:**  
Above Display SUF Security Lock Accessory ..... pg# 199



**IBA2(-W), IBA2AC(-W):**  
Recessed Cable Management and Power Storage Accessory Box ..... pg# 197



**IBA3(-W), IBA3AC(-W):**  
Recessed Cable Management and Power Storage Accessory Box ..... pg# 197



**IBA4-W:**  
Easy Mount Recessed Low Voltage Cable Plate ..... pg# 197



**IBA5-W:**  
Recessed Low Voltage Media Plate with Duplex Surge Suppressor ..... pg# 197

1. Ultra slim design holds displays only 0.19" (5mm) from the wall
2. Locking arm holds flat panel display in place and prevents accidental bump-offs and unwanted horizontal adjustments
3. Theft resistant security screw on locking arm
4. Easy three-step installation, mount the wall plate, hang the flat panel display and insert the locking arm
5. Fits displays with horizontal mounting hole patterns from 150 to 400mm and 550 to 800mm (in 25mm increments)

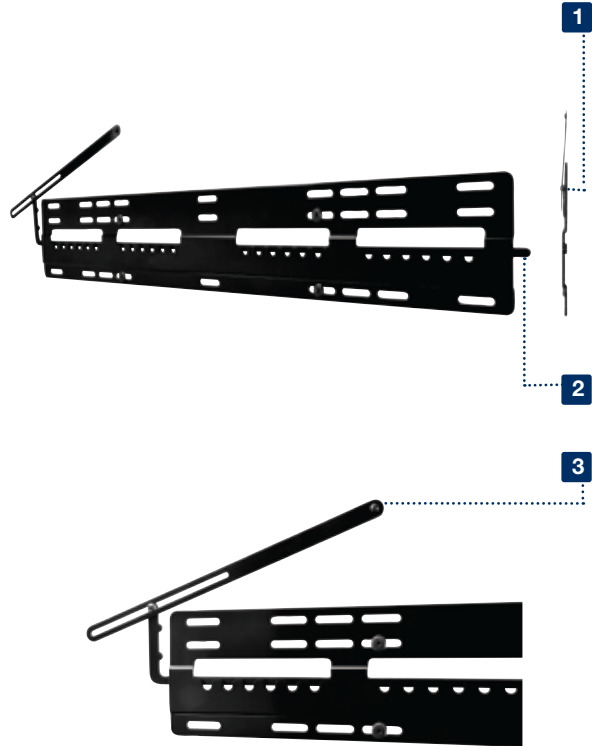

### Display Mounting Requirements

1. Designed for use with displays that are less than 2" (50.8mm) deep.
2. The depth of this mount (0.19" (5mm)) may not provide sufficient space for proper ventilation on some displays. Refer to the manufacturer's requirements for mounting the display before installation.
3. The display must have a flat mounting surface, or mounting holes need to be on the furthest back surface of the display.
4. Input/output connection must be properly orientated to accommodate mounting 0.19" (5mm) from the wall.

Patented

## TECHNICAL DRAWINGS

For expanded product information and technical data visit [www.peerless-av.com](http://www.peerless-av.com)

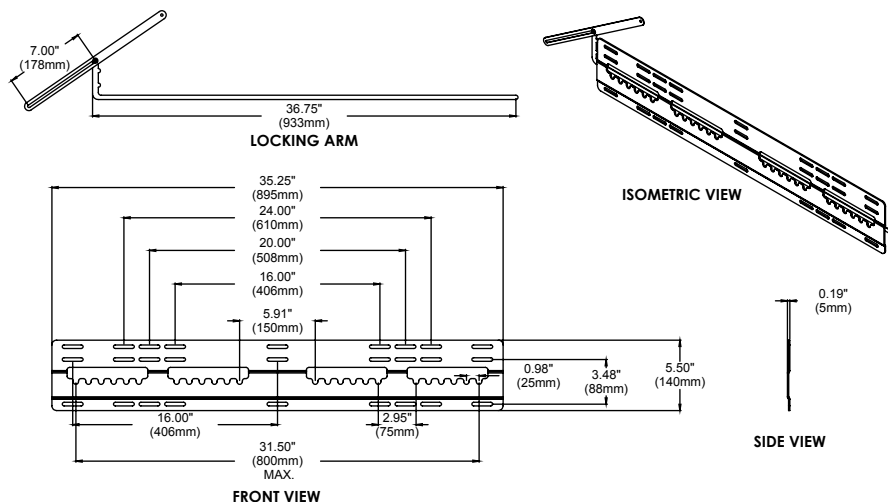

To verify mount compatibility with any flat panel display or projector model use MountFinder™ at [www.peerless-av.com](http://www.peerless-av.com)



CALL: 630-375-5100  
800-865-2112



FAX: 630-820-8537  
800-359-6500



E-MAIL:  
[info@peerless-av.com](mailto:info@peerless-av.com)



ONLINE:  
[www.peerless-av.com](http://www.peerless-av.com)



# Universal Ultra Slim Tilt Wall Mount

For 22" to 40" Ultra-thin Flat Panel Displays

1. Holds display 0.68" (17mm) from the wall
2. Display can be extended up to 3.88" (98mm) from the wall allowing for hand-free installation access to the back of the display
3. Full motion tilt allows for +17.5/-5°
4. Display adapter simply hooks onto wall plate for quick and easy installation

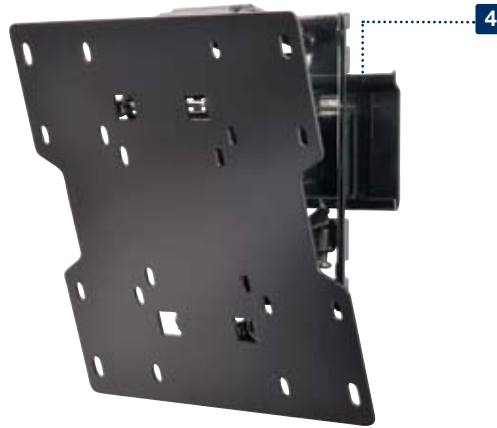

## Display Mounting Requirements

1. Designed for use with displays that are less than 2" (50.8mm) deep.
2. The depth of this mount (0.68" (17mm)) may not provide sufficient space for proper heat ventilation on some displays. Refer to the manufacturer's requirements for mounting the display before installation.
3. The display must have a flat mounting surface, or mounting holes need to be on the furthest back surface of the display.

Patented

For expanded product information and technical data visit [www.peerless-av.com](http://www.peerless-av.com)

## TECHNICAL DRAWINGS

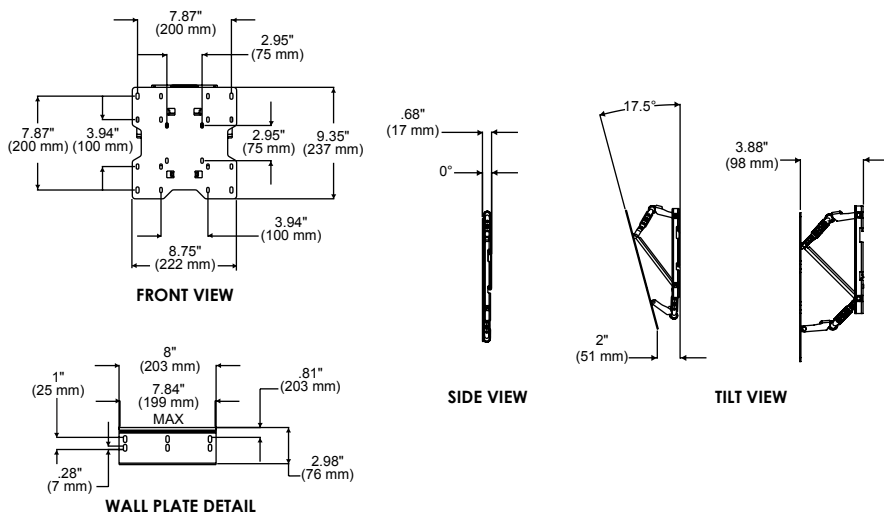

To verify mount compatibility with any flat panel display or projector model use MountFinder™ at [www.peerless-av.com](http://www.peerless-av.com)



**CALL:** 630-375-5100  
800-865-2112



**FAX:** 630-820-8537  
800-359-6500



**E-MAIL:**  
[info@peerless-av.com](mailto:info@peerless-av.com)



**ONLINE:**  
[www.peerless-av.com](http://www.peerless-av.com)



FLAT PANEL MOUNTS

## MODELS

### Universal Models:

Includes standard hardware (hex or Phillips) for attaching display to mount

**SUT632P\*** Gloss black

\* Designed for use with displays that are less than 2" (50.8mm) deep

## DISPLAY ADAPTER



### VESA® Pattern

Universal Models: 75, 100, 200 x 100 and 200 x 200mm

## SPECIFICATIONS



### Distance from Wall

0.68"-3.88" (17-98mm)



### Tilt

+17.5/-5°



### Max Load

60lb (27kg)

### Product Dimensions (W x H x D)

8.75" x 9.35" x 0.68"-3.88"  
(222 x 237 x 17-98mm)

### Mounting Surfaces

Wood stud, concrete, cinder block and metal stud (Metal stud accessory required)

### Ship Weight

4lb (1.8kg)

## CERTIFICATIONS



## ACCESSORIES



**ACC215:**  
2-pack Metal Stud Fastener Kit ..... pg# 196



**IBA2(-W), IBA2AC(-W):**  
Recessed Cable Management and Power Storage Accessory Box ..... pg# 197



**IBA3(-W), IBA3AC(-W):**  
Recessed Cable Management and Power Storage Accessory Box ..... pg# 197



**IBA4-W:**  
Easy Mount Recessed Low Voltage Cable Plate ..... pg# 197



**IBA5-W:**  
Recessed Low Voltage Media Plate with Duplex Surge Suppressor ..... pg# 197

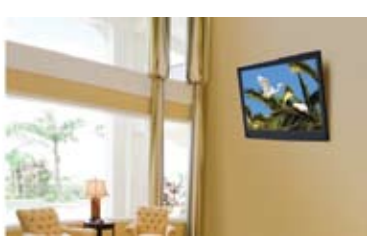

# Universal Ultra Slim Tilt Wall Mount

For 32" to 46" Ultra-thin Flat Panel Displays

## MODELS

### Universal Models:

Includes standard hardware (hex or Phillips) for attaching display to mount

**SUT645P\*** Gloss black

\* Designed for use with displays that are less than 2" (50.8mm) deep

## DISPLAY ADAPTER

### Mounting Pattern

Universal Models: 603 x 408mm  
(23.75"W x 16.06"H)

## SPECIFICATIONS

### Distance from Wall

0.68"-5.88" (17-149mm)

### Tilt

+17.5/-5°

### Max Load

100lb (45kg)

### Product Dimensions (W x H x D)

29.00" x 17.25" x 0.68"-5.88"  
(736 x 438 x 17-149mm)

### Mounting Surfaces

Wood stud, concrete, cinder block and metal stud  
(Metal stud accessory required)

### Ship Weight

11lb (5kg)

## CERTIFICATIONS



## ACCESSORIES



**ACC415:**  
4-pack Metal Stud  
Fastener Kit ..... pg# 196



**IBA2(-W), IBA2AC(-W):**  
Recessed Cable  
Management and Power  
Storage Accessory Box ..... pg# 197



**IBA3(-W), IBA3AC(-W):**  
Recessed Cable  
Management and Power  
Storage Accessory Box ..... pg# 197



**IBA4-W:**  
Easy Mount Recessed  
Low Voltage Cable Plate ..... pg# 197

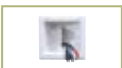

**IBA5-W:**  
Recessed Low Voltage  
Media Plate with Duplex  
Surge Suppressor ..... pg# 197

1. Holds display 0.68" (17mm) from the wall

2. Display can be extended up to 5.88" (149mm) from the wall allowing for hands-free installation access to the back of the display

3. Full motion tilt allows for +17.5/-5°

4. Display adapters simply hook onto wall plate for quick and easy installation

5. Horizontal adjustment up to 8" (203mm) for centering display on wall

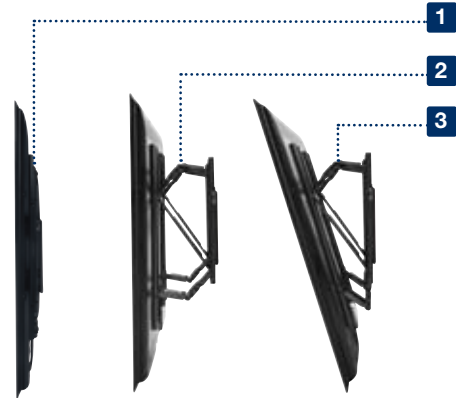

### Display Mounting Requirements

1. Designed for use with displays that are less than 2" (50.8mm) deep.
2. The depth of this mount (0.68" (17mm)) may not provide sufficient space for proper heat ventilation on some displays. Refer to the manufacturer's requirements for mounting the display before installation.
3. The display must have a flat mounting surface, or mounting holes need to be on the furthest back surface of the display.

Patented

## TECHNICAL DRAWINGS

For expanded product information and technical data visit [www.peerless-av.com](http://www.peerless-av.com)

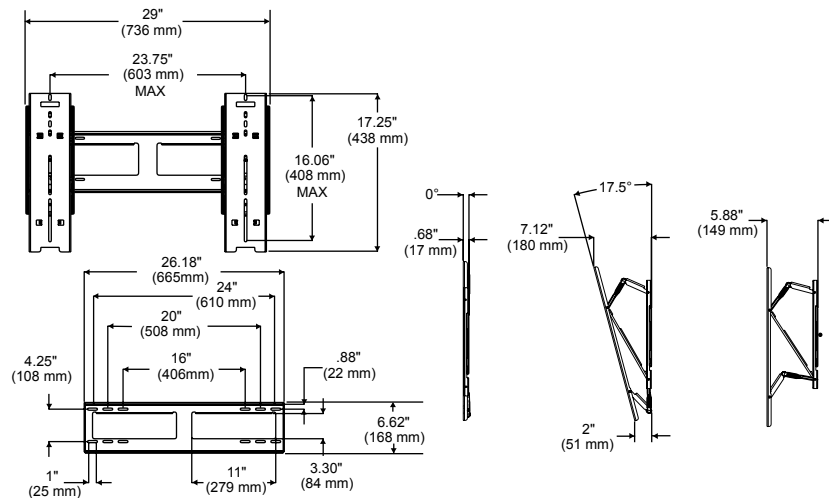

To verify mount compatibility with any flat panel display or projector model use MountFinder™ at [www.peerless-av.com](http://www.peerless-av.com)



CALL: 630-375-5100  
800-865-2112



FAX: 630-820-8537  
800-359-6500



E-MAIL:  
[info@peerless-av.com](mailto:info@peerless-av.com)



ONLINE:  
[www.peerless-av.com](http://www.peerless-av.com)



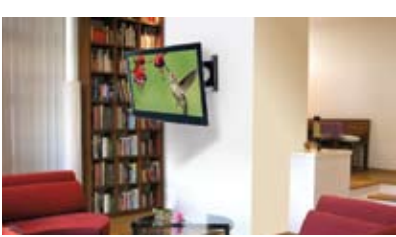

# Universal Ultra Slim Articulating Wall Arm

For 32" to 46" Ultra-thin Flat Panel Displays

## MODELS

Includes standard hardware (hex or Phillips) for attaching display to mount

### Universal Models:

**SUA746PU\***      Gloss black

### Dedicated Models:

**SUA737\***      Gloss black

\* Designed for use with displays that are less than 2" (50.8mm) deep

## DISPLAY ADAPTER



### Mounting Pattern

**Universal Models:**    450 x 402mm  
                                  (17.73"W x 15.81"H)



### VESA® Pattern

**Universal Models:**    200 x 100, 200 x 200  
                                  400 x 200 and 400 x 400mm

**Dedicated Models:**    200 x 100, 200 x 200mm

## SPECIFICATIONS



### Distance from Wall

**SUA746PU:**    1.27"-24.15" (32-613mm)  
**SUA737:**      1.29"-24.17" (33-614mm)



### Tilt | Swivel | Roll

+15/-5° | ±90° | ±5°



### Max Load

60lb (27kg)

### Product Dimensions (W x H x D)

**SUA746PU:**    20.15" x 16.75" x 1.27"-24.15"  
                                  (512 x 425 x 32-613mm)

**SUA737:**      15.85" x 13.00" x 1.29"-24.17"  
                                  (403 x 330 x 33-614mm)

### Mounting Surfaces

Wood stud, concrete  
and cinder block

### Ship Weight

**SUA746PU:**    14lb (6.35kg)  
**SUA737:**      10.5lb (4.76kg)

## CERTIFICATIONS



Pending

## ACCESSORIES



**ACC919:**  
Security Fasteners ..... pg# 195



**ACC-SB:**  
Soundbar/Center Channel  
Accessory Mount ..... pg# 185



**IBA2(-W), IBA2AC(-W):**  
Recessed Cable  
Management and Power  
Storage Accessory Box ..... pg# 193



**IBA3(-W), IBA3AC(-W):**  
Recessed Cable  
Management and Power  
Storage Accessory Box ..... pg# 193



**IBA4-W:**  
Easy Mount Recessed  
Low Voltage Cable Plate ..... pg# 193



**IBA5-W:**  
Recessed Low Voltage  
Media Plate with Duplex  
Surge Suppressor ..... pg# 193

## UPDATED DESIGN!

1. Arm retracts to 1.27" (32mm) and extends up to 24.15" (613mm) from wall
2. One-Touch™ tilt mechanism allows adjustment of +15/-5° without the use of tools
3. Up to ±90° of side-to-side swivel
4. Added ±5° of roll for post-installation display leveling without the use of tools

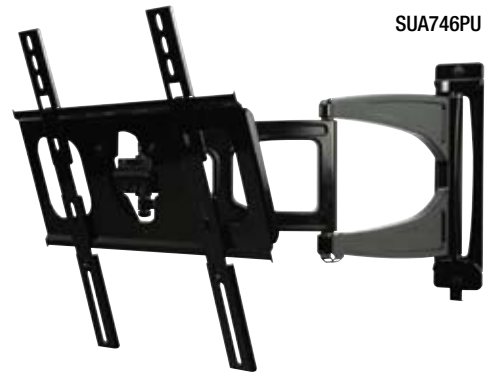

SUA746PU



SUA737

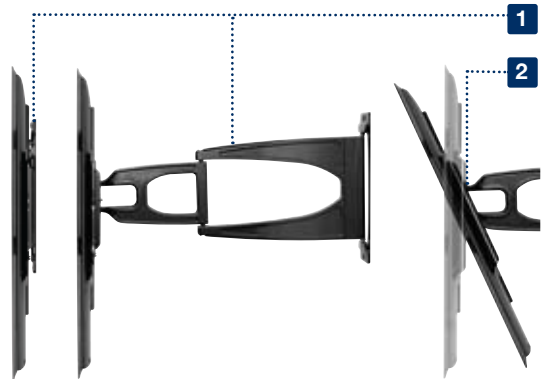

### Display Mounting Requirements

1. Designed for use with displays that are less than 2" (50.8mm) deep.
2. The display must have a flat mounting surface, or mounting holes need to be on the furthest back surface of the display.

Patented

## TECHNICAL DRAWINGS

For expanded product information and technical data visit [www.peerless-av.com](http://www.peerless-av.com)

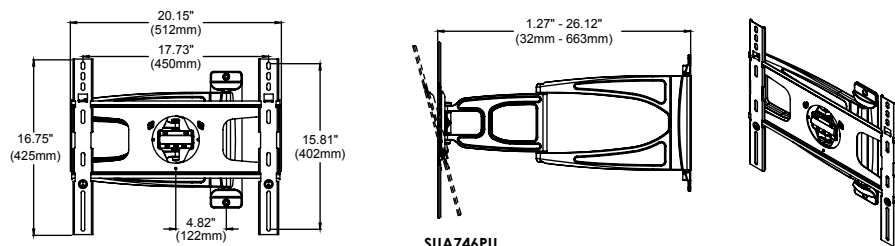

SUA746PU

SUA737

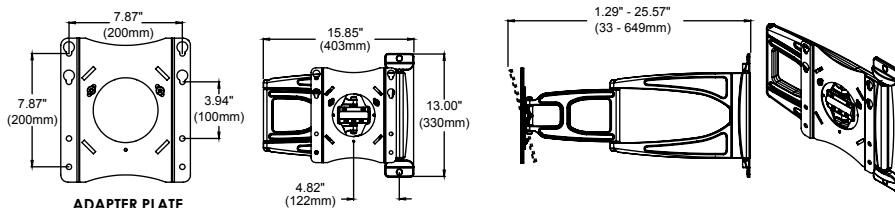

ADAPTER PLATE





# Universal Ultra Slim Articulating Wall Arm

For 37" to 55" Ultra-thin Flat Panel Displays



FLAT PANEL MOUNTS

## UPDATED DESIGN!

1. Arm retracts to 1.34" (34mm) and extends up to 24.19" (615mm) from wall
2. One-Touch™ tilt mechanism allows adjustment of +15/-5° without the use of tools
3. Up to ±90° of side-to-side swivel
4. Added ±5° of roll for post-installation display leveling without the use of tools

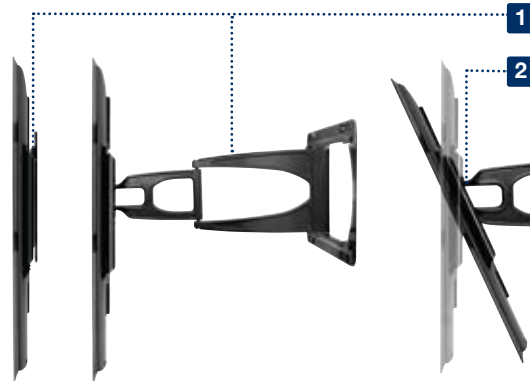

### Display Mounting Requirements

1. Designed for use with displays that are less than 2" (50.8mm) deep.
2. The display must have a flat mounting surface, or mounting holes need to be on the furthest back surface of the display.

Patented

For expanded product information and technical data visit [www.peerless-av.com](http://www.peerless-av.com)

## TECHNICAL DRAWINGS

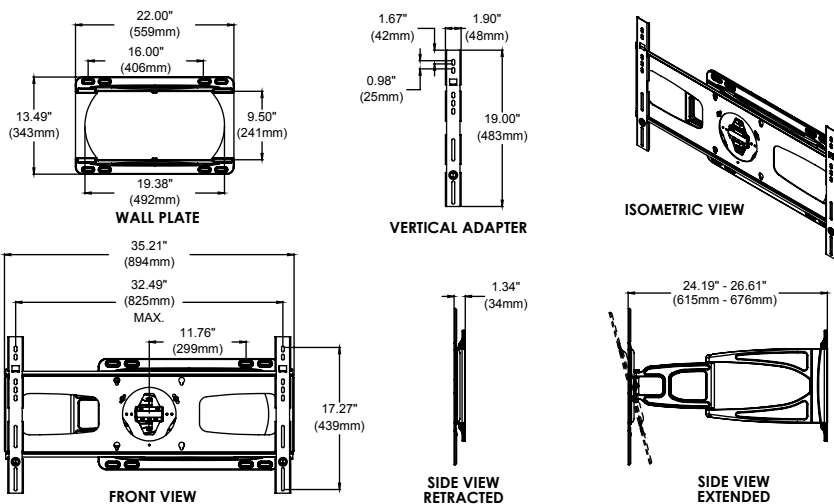

## MODELS

### Universal Models:

Includes standard hardware (hex or Phillips) for attaching display to mount

**SUA751PU\*** Gloss black

\* Designed for use with displays that are less than 2" (50.8mm) deep

## DISPLAY ADAPTER



### Mounting Pattern

Universal Models: 825 x 439mm (32.49"W x 17.27"H)



### VESA® Pattern

Universal Models: 200 x 100, 200 x 200, 400 x 200, 400 x 400 and 800 x 400mm

## SPECIFICATIONS



### Distance from Wall

1.34"-24.19" (34-615mm)



### Tilt | Swivel | Roll

+15/-5° | ±90° | ±5°



### Max Load

100lb (45kg)

### Product Dimensions (W x H x D)

35.21" x 19.00" x 1.34"-24.19" (894 x 483 x 34-615mm)

### Mounting Surfaces

Wood stud, concrete and cinder block

### Ship Weight

25lb (11.34kg)

## CERTIFICATIONS

RoHS

MADE IN USA

## ACCESSORIES



### ACC925:

Security Fasteners ..... pg# 199



### ACC-SB:

Soundbar/Center Channel Accessory Mount ..... pg# 189



### BA2(-W), IBA2AC(-W):

Recessed Cable Management and Power Storage Accessory Box ..... pg# 197



### IBA3(-W), IBA3AC(-W):

Recessed Cable Management and Power Storage Accessory Box ..... pg# 197



### IBA4-W:

Easy Mount Recessed Low Voltage Cable Plate ..... pg# 197



### IBA5-W:

Recessed Low Voltage Media Plate with Duplex Surge Suppressor ..... pg# 197

To verify mount compatibility with any flat panel display or projector model use MountFinder™ at [www.peerless-av.com](http://www.peerless-av.com)



CALL: 630-375-5100  
800-865-2112



FAX: 630-820-8537  
800-359-6500



E-MAIL: [info@peerless-av.com](mailto:info@peerless-av.com)



ONLINE: [www.peerless-av.com](http://www.peerless-av.com)

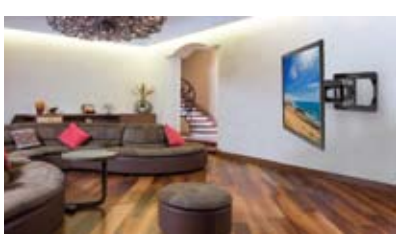

# Universal Ultra Slim Articulating Wall Arm

For 42" to 65" Ultra-thin Flat Panel Displays

## MODELS

### Universal Models:

Includes standard hardware (hex or Phillips) for attaching display to mount

**SUA765PU\*** Glass black

\* Designed for use with displays that are less than 2" (50.8mm) deep

## DISPLAY ADAPTER

### Mounting Pattern

Universal Models: 854 x 439mm  
(33.6"W x 17.27"H)

### VESA® Pattern

Universal Models: 100 x 100, 200 x 100, 200 x 200, 400 x 200, 400 x 400 and 800 x 400mm

## SPECIFICATIONS

### Distance from Wall

1.24"-28.16" (32-715mm)

### Tilt | Swivel | Roll

+15/-5° | ±72.5° | ±1°

### Max Load

100lb (45kg)

### Product Dimensions (W x H x D)

38.17" x 19.00" x 1.24"-28.16"  
(969 x 483 x 32-715mm)

### Mounting Surfaces

Wood stud, concrete and cinder block

### Ship Weight

31lb (14.06kg)

## CERTIFICATIONS



## ACCESSORIES



**ACC925:** Security Fasteners ..... pg# 199



**ACC-SB:** Soundbar/Center Channel Accessory Mount ..... pg# 189



**BA2(-W), IBA2AC(-W):** Recessed Cable Management and Power Storage Accessory Box ..... pg# 197



**IBA3(-W), IBA3AC(-W):** Recessed Cable Management and Power Storage Accessory Box ..... pg# 197



**IBA4-W:** Easy Mount Recessed Low Voltage Cable Plate ..... pg# 197

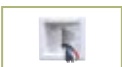

**IBA5-W:** Recessed Low Voltage Media Plate with Duplex Surge Suppressor ..... pg# 197

1. Dual-arm design enhances the stability of the articulating motion
2. Arm retracts to 1.24" (32mm) and extends up to 28.16" (715mm) from wall
3. One-Touch™ tilt mechanism allows adjustment of +15/-5° without the use of tools
4. Up to ±72.5° of side-to-side swivel
5. ±1° of roll for post-installation display leveling

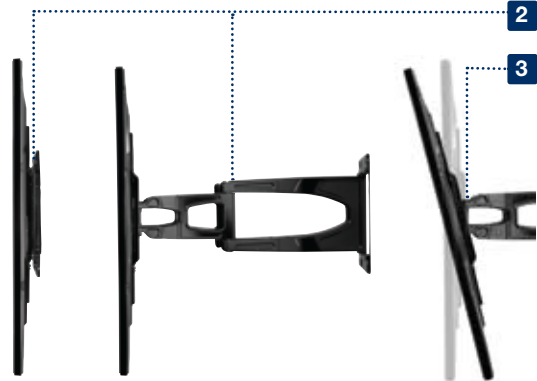

### Display Mounting Requirements

1. Designed for use with displays that are less than 2" (50.8mm) deep.
2. The display must have a flat mounting surface, or mounting holes need to be on the furthest back surface of the display.

Patented

## TECHNICAL DRAWINGS

For expanded product information and technical data visit [www.peerless-av.com](http://www.peerless-av.com)

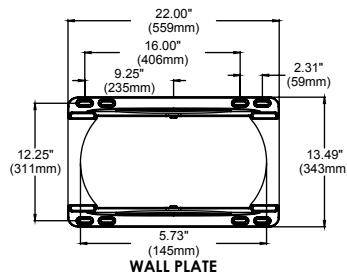

WALL PLATE

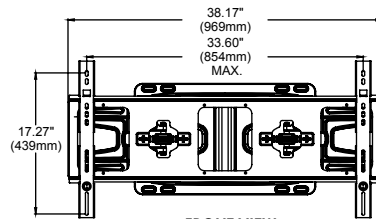

FRONT VIEW

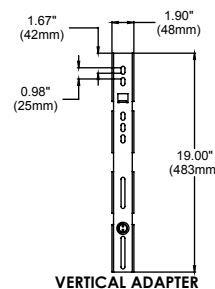

VERTICAL ADAPTER



SIDE VIEW

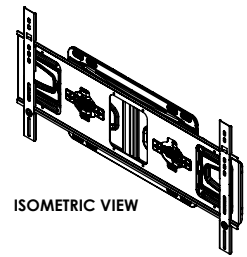

ISOMETRIC VIEW

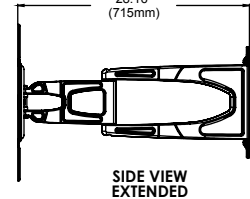

SIDE VIEW EXTENDED

To verify mount compatibility with any flat panel display or projector model use MountFinder™ at [www.peerless-av.com](http://www.peerless-av.com)

CALL: 630-375-5100  
800-865-2112

FAX: 630-820-8537  
800-359-6500

E-MAIL: [info@peerless-av.com](mailto:info@peerless-av.com)

ONLINE: [www.peerless-av.com](http://www.peerless-av.com)

# Ultra Slim Motorized Wall Mount

For 23" to 46" Ultra-thin Flat Panel Displays

1. Arm retracts to 1.375" (34.9mm) and extends up to 8.375" (212.7mm) from wall
2. Pivots up to 40° (20° in each direction)
3. Remote control operation with preset positions
4. Automatic display centering and wall detection
5. Near silent (25dB) motor operation

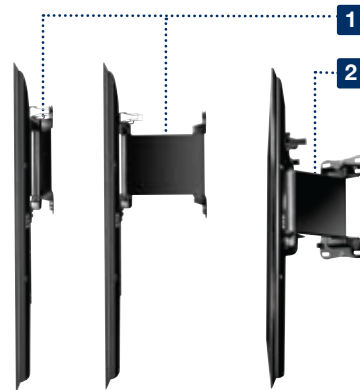

## Display Mounting Requirements

1. Designed for use with displays that are less than 2" (50.8mm) deep.

For expanded product information and technical data visit [www.peerless-av.com](http://www.peerless-av.com)

## TECHNICAL DRAWINGS

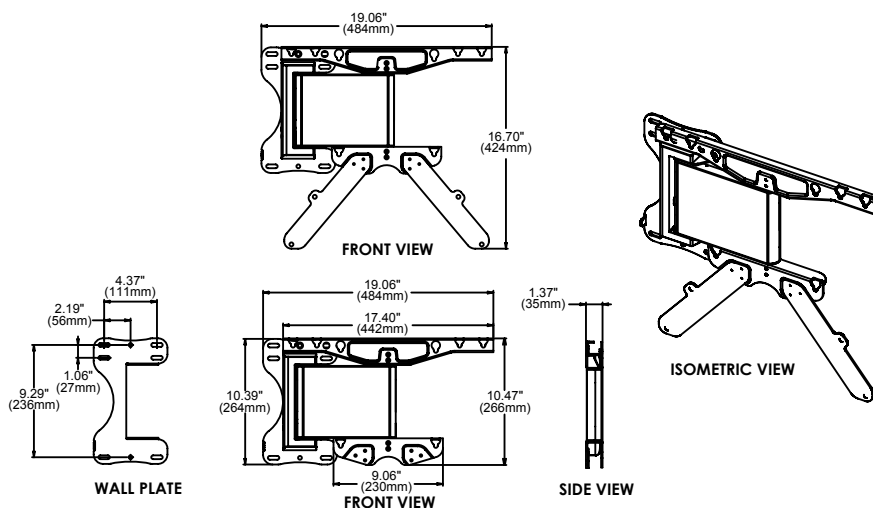

FLAT PANEL MOUNTS

## MODELS

### Universal Models:

Includes standard hardware (hex or Phillips) for attaching display to mount

**MM746PU\*** Gloss black

\* Designed for use with displays that are less than 2" (50.8mm) deep

## DISPLAY ADAPTER



### VESA® Pattern

Universal Models: 200 x 200, 300 x 300 and 400 x 400mm

## SPECIFICATIONS



### Distance from Wall

1.375"-8.375" (34.9-212.7mm)



### Swivel

Up to 40° (20° in each direction)



### Max Load

110lb (50kg)

### Product Dimensions (W x H x D)

19.06" x 10.47"-16.70" x 1.375-8.375"  
(484 x 266-424 x 35-212.7mm)

### Mounting Surfaces

Wood stud and concrete

### Ship Weight

26lb (11.79kg)

To verify mount compatibility with any flat panel display or projector model use MountFinder™ at [www.peerless-av.com](http://www.peerless-av.com)



CALL: 630-375-5100  
800-865-2112



FAX: 630-820-8537  
800-359-6500



E-MAIL: [info@peerless-av.com](mailto:info@peerless-av.com)



ONLINE: [www.peerless-av.com](http://www.peerless-av.com)



# SMARTMOUNT Xt Universal Flat Wall Mount

For 32" to 46" Flat Panel Displays

## MODELS

### Universal Models:

Includes theft resistant hardware for attaching display to mount

**SFX645** Ravens black

Includes standard hardware (hex or Phillips) for attaching display to mount

**SFX645P** Ravens black

## SCREEN ADAPTER



### Mounting Pattern

Universal Models: 452 x 433mm  
(17.79"W x 17.04"H)



### VESA® Pattern

Universal Models: Up to 400 x 400mm

## SPECIFICATIONS



### Distance from Wall

1.21" (31mm)



### Max Load

80lb (36kg)

### Product Dimensions (W x H x D)

19.37" x 18.00" x 1.21"  
(492 x 457 x 31mm)

### Mounting Surfaces

Wood stud, concrete, cinder block and metal stud  
(Metal stud accessory required)

### Ship Weight

6.5lb (2.95kg)

## CERTIFICATIONS



OSHDP Approval Pending

## ACCESSORIES



**ACC415:**  
4-pack Metal Stud  
Fastener Kit ..... pg# 196



**ACCXT302:**  
Video Conferencing Shelf..... pg# 189



**IBA4-W:**  
Easy Mount Recessed  
Low Voltage Cable Plate ..... pg# 197



**ACCXT402:**  
Recessed Power Outlet  
with Low Voltage  
In-Wall Cable Routing ..... pg# 189

1. Low-profile design holds display 1.21" (31mm) from wall
2. Up to 1" (25mm) of vertical adjustment on each universal display adapter bracket for post-installation leveling and height adjustment fine-tuning
3. Up to 13" (330mm) of horizontal display adjustment for centering display on wall
4. Open wall plate design allows for total wall access, increasing electrical and cable management options
5. Easy-Glide™ design ensures that the display is securely attached to the wall plate
6. Universal display adapter brackets easily hook onto wall plate for fast installation
7. Fits displays with mounting hole patterns from 75 x 75mm (2.95"W x 2.95"H) to 452 x 433mm (17.79"W x 17.04"H)



Patent Pending

### Reseller Authorization Required



INTEGRATED  
PARTNER  
PROGRAM

## TECHNICAL DRAWINGS

For expanded product information and technical data visit [www.peerless-av.com](http://www.peerless-av.com)

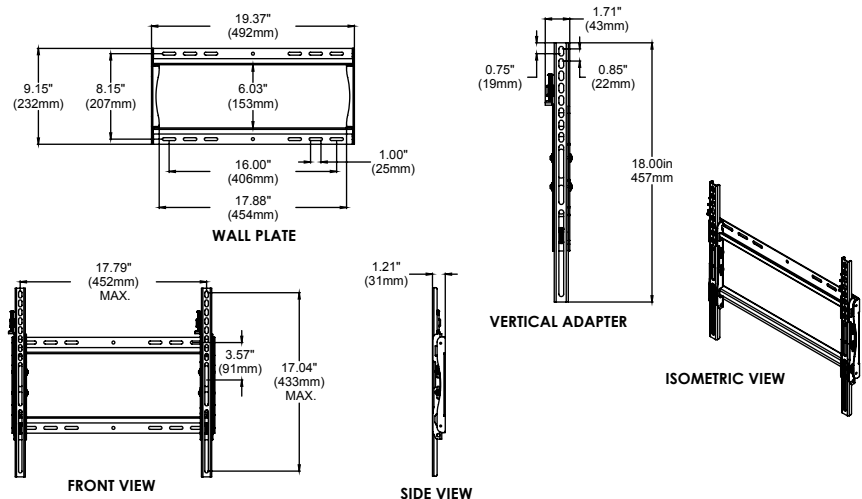

To verify mount compatibility with any flat panel display or projector model use MountFinder™ at [www.peerless-av.com](http://www.peerless-av.com)



CALL: 630-375-5100  
800-865-2112



FAX: 630-820-8537  
800-359-6500



E-MAIL: [info@peerless-av.com](mailto:info@peerless-av.com)



ONLINE: [www.peerless-av.com](http://www.peerless-av.com)



# SMARTMOUNT Xt Universal Flat Wall Mount

For 32" to 55" Flat Panel Displays



FLAT PANEL MOUNTS

1. Low-profile design holds display 1.21" (31mm) from wall
2. Up to 1" (25mm) of vertical adjustment on each universal display adapter bracket for post-installation leveling and height adjustment fine-tuning
3. Up to 25" (635mm) of horizontal display adjustment for centering display on wall
4. Open wall plate design allows for total wall access, increasing electrical and cable management options
5. Easy-Glide™ design ensures that the display is securely attached to the wall plate
6. Universal display adapter brackets easily hook onto wall plate for fast installation
7. Fits displays with mounting hole patterns from 75 x 75mm (2.95"W x 2.95"H) to 744 x 433mm (29.29"W x 17.04"H)



Reseller Authorization Required



INTEGRATED PARTNER PROGRAM

Patent Pending

For expanded product information and technical data visit [www.peerless-av.com](http://www.peerless-av.com)

## TECHNICAL DRAWINGS

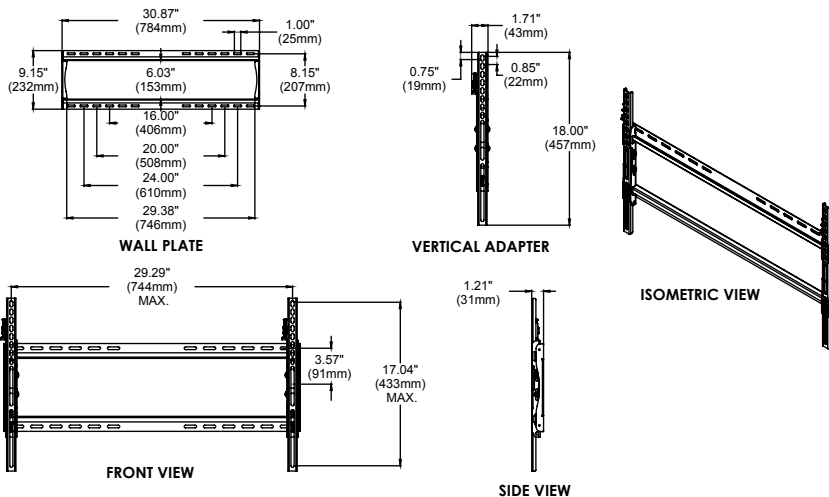

## MODELS

### Universal Models:

- Includes theft resistant hardware for attaching display to mount
- SFX650** Ravens black
- Includes standard hardware (hex or Phillips) for attaching display to mount
- SFX650P** Ravens black

## DISPLAY ADAPTER



### Mounting Pattern

Universal Models: 744 x 433mm (29.29"W x 17.04"H)



### VESA® Pattern

Universal Models: Up to 600 x 400mm

## SPECIFICATIONS



### Distance from Wall

1.21" (31mm)



### Max Load

120lb (54kg)

### Product Dimensions (W x H x D)

30.87" x 18.00" x 1.21" (784 x 457 x 31mm)

### Mounting Surfaces

Wood stud, concrete, cinder block and metal stud (Metal stud accessory required)

### Ship Weight

8.3lb (3.76kg)

## CERTIFICATIONS



Pending



OSHPD Approval Pending

## ACCESSORIES



**ACC415:**  
4-pack Metal Stud Fastener Kit ..... pg# 196



**ACCX302:**  
Video Conferencing Shelf..... pg# 189



**IBA4-W:**  
Easy Mount Recessed Low Voltage Cable Plate ..... pg# 197



**ACCX402:**  
Recessed Power Outlet with Low Voltage In-Wall Cable Routing ..... pg# 189

To verify mount compatibility with any flat panel display or projector model use MountFinder™ at [www.peerless-av.com](http://www.peerless-av.com)



CALL: 630-375-5100  
800-865-2112



FAX: 630-820-8537  
800-359-6500



E-MAIL: [info@peerless-av.com](mailto:info@peerless-av.com)



ONLINE: [www.peerless-av.com](http://www.peerless-av.com)



# SMARTMOUNT Xt Universal Flat Wall Mount

For 46" to 70" Flat Panel Displays

## MODELS

### Universal Models:

Includes theft resistant hardware for attaching display to mount

**SFX660** Ravens black

Includes standard hardware (hex or Phillips) for attaching display to mount

**SFX660P** Ravens black

## SCREEN ADAPTER



### Mounting Pattern

Universal Models: 827 x 433mm  
(32.54"W x 17.04"H)



### VESA® Pattern

Universal Models: Up to 700 x 600mm

## SPECIFICATIONS



### Distance from Wall

1.21" (31mm)



### Max Load

150lb (68kg)

### Product Dimensions (W x H x D)

34.12" x 18.00" x 1.21"  
(867 x 457 x 31mm)

### Mounting Surfaces

Wood stud, concrete, cinder block and metal stud  
(Metal stud accessory required)

### Ship Weight

9.7lb (4.4kg)

## CERTIFICATIONS



Pending

OSHDP Approval Pending

## ACCESSORIES



**ACC415:**  
4-pack Metal Stud  
Fastener Kit ..... pg# 196



**ACCXT302:**  
Video Conferencing Shelf..... pg# 189



**IBA4-W:**  
Easy Mount Recessed  
Low Voltage Cable Plate ..... pg# 197



**ACCXT402:**  
Recessed Power Outlet  
with Low Voltage  
In-Wall Cable Routing ..... pg# 189

1. Low-profile design holds display 1.21" (31mm) from wall
2. Up to 1" (25mm) of vertical adjustment on each universal display adapter bracket for post-installation leveling and height adjustment fine-tuning
3. Up to 24" (610mm) of horizontal display adjustment for centering display on wall
4. Open wall plate design allows for total wall access, increasing electrical and cable management options
5. Easy-Glide™ design ensures that the display is securely attached to the wall plate
6. Universal display adapter brackets easily hook onto wall plate for fast installation
7. Fits displays with mounting hole patterns from 75 x 75mm (2.95"W x 2.95"H) to 827 x 433mm (32.54"W x 17.04"H)

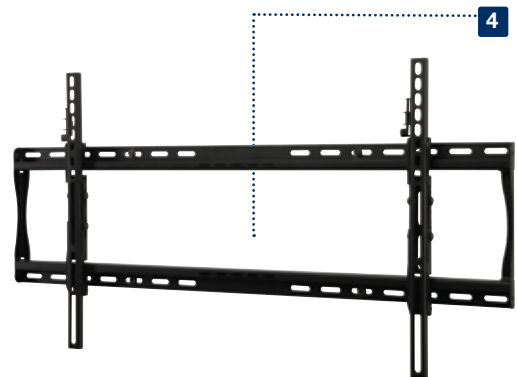

### Reseller Authorization Required



INTEGRATED  
PARTNER  
PROGRAM

Patent Pending

## TECHNICAL DRAWINGS

For expanded product information and technical data visit [www.peerless-av.com](http://www.peerless-av.com)

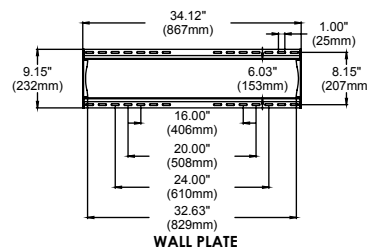

WALL PLATE

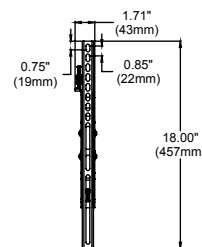

VERTICAL ADAPTER

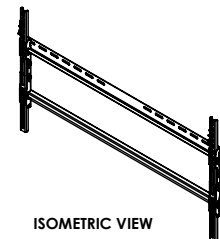

ISOMETRIC VIEW

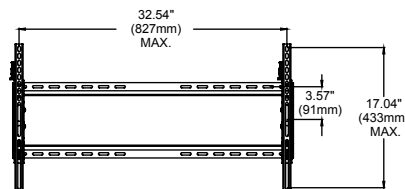

FRONT VIEW



SIDE VIEW

To verify mount compatibility with any flat panel display or projector model use MountFinder™ at [www.peerless-av.com](http://www.peerless-av.com)



CALL: 630-375-5100  
800-865-2112



FAX: 630-820-8537  
800-359-6500



E-MAIL: [info@peerless-av.com](mailto:info@peerless-av.com)



ONLINE: [www.peerless-av.com](http://www.peerless-av.com)

# SMARTMOUNT Xt Universal Tilt Wall Mount

For 32" to 46" Flat Panel Displays

1. Low-profile design holds display 1.69" (43mm) from wall
2. Increased security with included Master Lock 510KAD keyed-alike padlock on SXT645L only
3. Universal tilt adapter brackets offer up to +15/-5° of One-Touch™ tilt adjustment in one easy motion
4. Included IncreLok™ feature offers fixed tilt lock in 5° increments when used
5. Up to 1" (25mm) of vertical adjustment on each universal display adapter bracket for post-installation leveling and height adjustment fine-tuning
6. Up to 13" (330mm) of horizontal display adjustment for centering display on wall
7. Open wall plate design allows for total wall access, increasing electrical and cable management options
8. Universal tilt adapter brackets easily hook onto wall plate for fast installation
9. Fits displays with mounting hole patterns from 100 x 100mm (3.94"W x 3.94"H) to 431 x 433mm (16.96"W x 17.04"H)
10. 5° of negative tilt offers 3" (76mm) of space for hands-free, behind the display access

Patent Pending

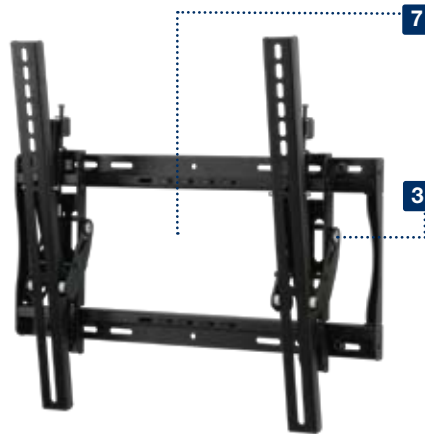

Reseller Authorization Required



INTEGRATED PARTNER PROGRAM

For expanded product information and technical data visit [www.peerless-av.com](http://www.peerless-av.com)

## TECHNICAL DRAWINGS

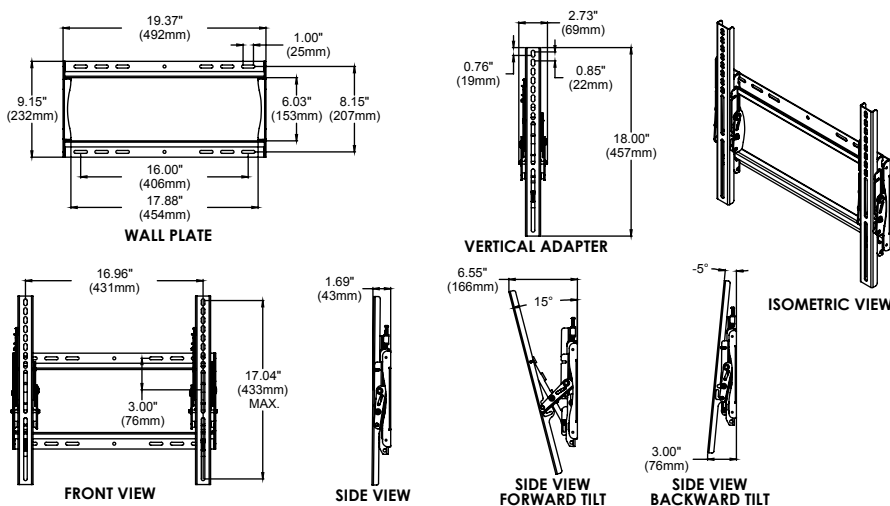

To verify mount compatibility with any flat panel display or projector model use MountFinder™ at [www.peerless-av.com](http://www.peerless-av.com)



CALL: 630-375-5100  
800-865-2112



FAX: 630-820-8537  
800-359-6500



E-MAIL: [info@peerless-av.com](mailto:info@peerless-av.com)



ONLINE: [www.peerless-av.com](http://www.peerless-av.com)

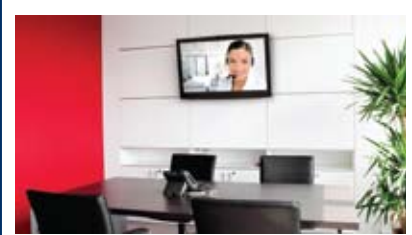

FLAT PANEL MOUNTS

## MODELS

### Universal Models:

Includes theft resistant hardware for attaching display to mount

**STX645** Ravens black  
**STX645L** Ravens black Locking

Includes standard hardware (hex or Phillips) for attaching display to mount

**STX645P** Ravens black

## DISPLAY ADAPTER



### Mounting Pattern

Universal Models: 431 x 433mm  
(16.96"W x 17.04"H)



### VESA® Pattern

Universal Models: Up to 400 x 400mm

## SPECIFICATIONS



### Distance from Wall

1.69"-6.55" (43-166mm)



### Tilt

+15/-5°



### Max Load

80lb (36kg)

### Product Dimensions (W x H x D)

19.37" x 18.00" x 1.69"-6.55"  
(492 x 457 x 43-166mm)

### Mounting Surfaces

Wood stud, concrete, cinder block and metal stud  
(Metal stud accessory required)

### Ship Weight

9.1lb (4.13kg)

## CERTIFICATIONS



Pending

OSHPD Approval Pending

## ACCESSORIES



**ACC415:**  
4-pack Metal Stud Fastener Kit ..... pg# 196



**ACCX302:**  
Video Conferencing Shelf..... pg# 189



**IBA4-W:**  
Easy Mount Recessed Low Voltage Cable Plate ..... pg# 197



**ACCX402:**  
Recessed Power Outlet with Low Voltage In-Wall Cable Routing ..... pg# 189



# SMARTMOUNT Xt Universal Tilt Wall Mount

For 32" to 55" Flat Panel Displays

## MODELS

### Universal Models:

Includes theft resistant hardware for attaching display to mount

**STX650** Ravens black  
**STX650L** Ravens black Locking

Includes standard hardware (hex or Phillips) for attaching display to mount

**STX650P** Ravens black

## SCREEN ADAPTER



### Mounting Pattern

Universal Models: 723 x 433mm  
 (28.46"W x 17.04"H)



### VESA® Pattern

Universal Models: Up to 600 x 400mm

## SPECIFICATIONS



### Distance from Wall

1.69"-6.55" (43-166mm)



### Tilt

+15/-5°



### Max Load

120lb (54kg)

### Product Dimensions (W x H x D)

30.87" x 18.00" x 1.69"-6.55"  
 (784 x 457 x 43-166mm)

### Mounting Surfaces

Wood stud, concrete, cinder block and metal stud  
 (Metal stud accessory required)

### Ship Weight

11lb (4.99kg)

## CERTIFICATIONS



OSHPD Approval Pending

## ACCESSORIES



**ACC415:**  
 4-pack Metal Stud  
 Fastener Kit ..... pg# 196



**ACCXT302:**  
 Video Conferencing Shelf ..... pg# 189



**IBA4-W:**  
 Easy Mount Recessed  
 Low Voltage Cable Plate ..... pg# 197



**ACCXT402:**  
 Recessed Power Outlet  
 with Low Voltage  
 In-Wall Cable Routing ..... pg# 189

1. Low-profile design holds display 1.69" (43mm) from wall
2. Increased security with included Master Lock 510KAD keyed-alike padlock on STX650L only
3. Universal tilt adapter brackets offer up to +15/-5° of One-Touch™ tilt adjustment in one easy motion
4. Included IncreLok™ feature offers fixed tilt lock in 5° increments when used
5. Up to 1" (25mm) of vertical adjustment on each universal display adapter bracket for post-installation leveling and height adjustment fine-tuning
6. Up to 24" (610mm) of horizontal display adjustment for centering display on wall
7. Open wall plate design allows for total wall access, increasing electrical and cable management options
8. Universal tilt adapter brackets easily hook onto wall plate for fast installation
9. Fits displays with mounting hole patterns from 100 x 100mm (3.94"W x 3.94"H) to 723 x 433mm (28.46"W x 17.04"H)
10. 5° of negative tilt offers 3" (76mm) of space for hands-free, behind the display access

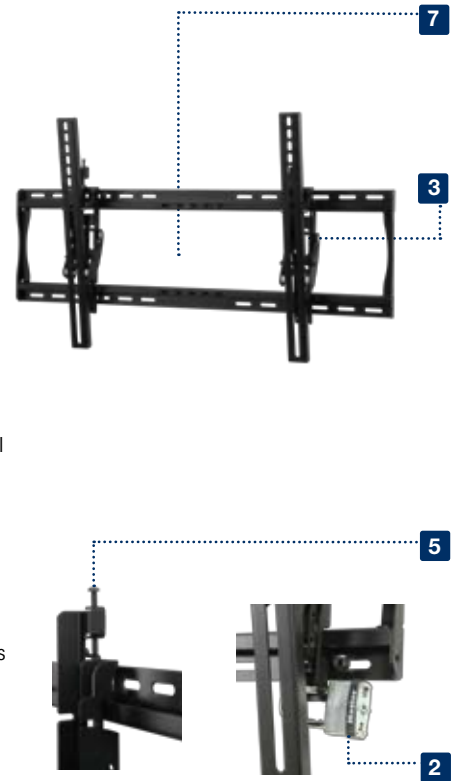

### Reseller Authorization Required



INTEGRATED  
 PARTNER  
 PROGRAM

Patent Pending

## TECHNICAL DRAWINGS

For expanded product information and technical data visit [www.peerless-av.com](http://www.peerless-av.com)

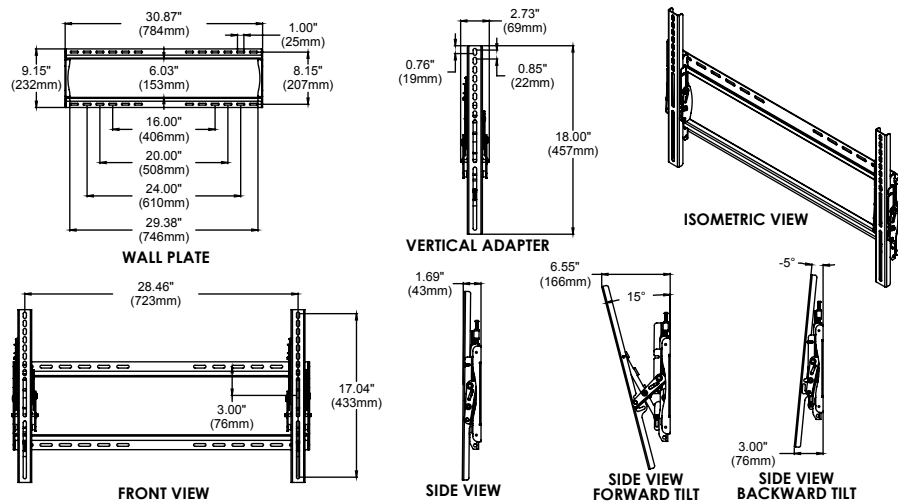

To verify mount compatibility with any flat panel display or projector model use MountFinder™ at [www.peerless-av.com](http://www.peerless-av.com)



CALL: 630-375-5100  
 800-865-2112



FAX: 630-820-8537  
 800-359-6500



E-MAIL:  
[info@peerless-av.com](mailto:info@peerless-av.com)



ONLINE:  
[www.peerless-av.com](http://www.peerless-av.com)



# SMARTMOUNT Xt Universal Tilt Wall Mount

For 46" to 70" Flat Panel Displays

1. Low-profile design holds display 1.69" (43mm) from wall
2. Increased security with included Master Lock 510KAD keyed-alike padlock on STX660L only
3. Universal tilt adapter brackets offer up to +15/-5° of One-Touch™ tilt adjustment in one easy motion
4. Included IncreLok™ feature offers fixed tilt lock in 5° increments when used
5. Up to 1" (25mm) of vertical adjustment on each universal display adapter bracket for post-installation leveling and height adjustment fine-tuning
6. Up to 23" (584mm) of horizontal display adjustment for centering display on wall
7. Open wall plate design allows for total wall access, increasing electrical and cable management options
8. Universal tilt adapter brackets easily hook onto wall plate for fast installation
9. Fits displays with mounting hole patterns from 100 x 100mm (3.94"W x 3.94"H) to 805 x 433mm (31.71"W x 17.04"H)
10. 5° of negative tilt offers 3" (76mm) of space for hands-free, behind the display access

Patent Pending

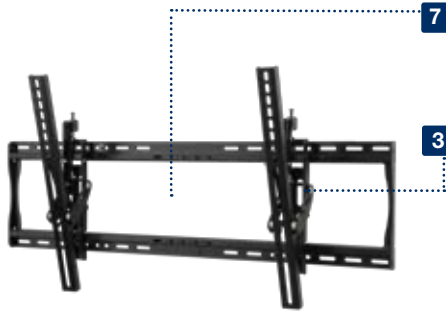

Reseller Authorization Required



INTEGRATED PARTNER PROGRAM

For expanded product information and technical data visit [www.peerless-av.com](http://www.peerless-av.com)

## TECHNICAL DRAWINGS

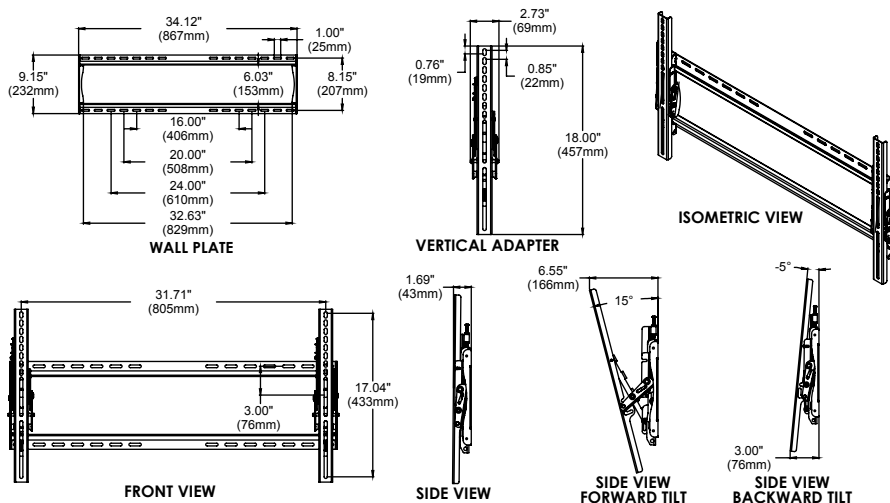

To verify mount compatibility with any flat panel display or projector model use MountFinder™ at [www.peerless-av.com](http://www.peerless-av.com)



CALL: 630-375-5100  
800-865-2112



FAX: 630-820-8537  
800-359-6500



E-MAIL: [info@peerless-av.com](mailto:info@peerless-av.com)



ONLINE: [www.peerless-av.com](http://www.peerless-av.com)

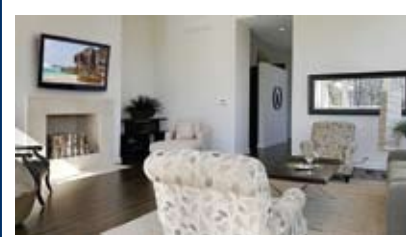

FLAT PANEL MOUNTS

## MODELS

### Universal Models:

Includes theft resistant hardware for attaching display to mount

**STX660** Ravens black  
**STX660L** Ravens black Locking

Includes standard hardware (hex or Phillips) for attaching display to mount

**STX660P** Ravens black

## DISPLAY ADAPTER



### Mounting Pattern

Universal Models: 805 x 433mm  
(31.71"W x 17.04"H)



### VESA® Pattern

Universal Models: Up to 600 x 400mm

## SPECIFICATIONS



### Distance from Wall

1.69"-6.55" (43-166mm)



### Tilt

+15/-5°



### Max Load

150lb (68kg)

### Product Dimensions (W x H x D)

34.12" x 18.00" x 1.69"-6.55"  
(867 x 457 x 43-166mm)

### Mounting Surfaces

Wood stud, concrete, cinder block and metal stud  
(Metal stud accessory required)

### Ship Weight

11.7lb (5.31kg)

## CERTIFICATIONS



Pending



OSHPD Approval Pending

## ACCESSORIES



**ACC415:**  
4-pack Metal Stud Fastener Kit ..... pg# 196



**ACCXT302:**  
Video Conferencing Shelf..... pg# 189



**IBA4-W:**  
Easy Mount Recessed Low Voltage Cable Plate ..... pg# 197



**ACCXT402:**  
Recessed Power Outlet with Low Voltage In-Wall Cable Routing ..... pg# 189

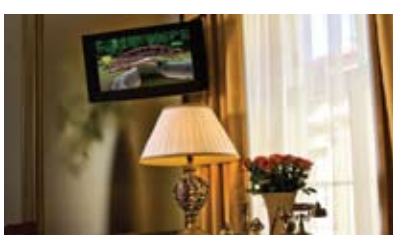

# SMARTMOUNT Xt Articulating Wall Arm

For 40" to 52" Flat Panel Displays

## MODELS

### Universal Models:

Includes theft resistant hardware for attaching display to mount  
**SAX755PU** Ravens black

## SCREEN ADAPTER



### Mounting Pattern

Universal Models: 661 x 449mm  
 (26.03"W x 17.69"H)



### VESA® Pattern

Universal Models: Up to 600 x 400mm

## SPECIFICATIONS



### Distance from Wall

2.54"-26.41" (65-671mm)



### Tilt | Swivel | Roll

+15/-5° | ±90° | ±90°



### Max Load

80lb (36kg)



### Landscape to Portrait

Display can be rotated landscape to portrait without removing the display

### Product Dimensions (W x H x D)

29.00" x 19.50" x 2.54"-26.41"  
 (737 x 495 x 65-671mm)

### Mounting Surfaces

Wood stud, concrete, cinder block and metal stud  
 (Metal stud accessory required)

1. Low-profile when retracted at 2.54" (65mm) and can extend up to 26.41" (671mm) from the wall
2. Internal cable management provides ample area to run cables to complete a clean, professional installation
3. One-Touch™ tilt mechanism allows adjustment of +15/-5° without the use of tools
4. ±5° of roll for post-installation leveling
5. Display can be rotated from landscape to portrait without removing the display
6. ±0.5" (13mm) of vertical adjustment for post-installation height adjustment fine-tuning
7. Single stud wall plate design increases electrical and cable management options



### Reseller Authorization Required



INTEGRATED PARTNER PROGRAM

## CERTIFICATIONS



OSHPD Approval Pending

Pending

## ACCESSORIES



**ACC415:**  
 4-pack Metal Stud Fastener Kit ..... pg# 196



**ACC955:**  
 Component Shelf Accessory... pg#189



**ACCXT100:**  
 Left & Right Speaker Accessory Mount ..... pg# 189



**ACCXT200:**  
 Soundbar and Center Channel Accessory Mount..... pg# 189



**ACCXT300:**  
 Video Conferencing Shelf Accessory ..... pg# 189



**IBA4-W:**  
 Easy Mount Recessed Low Voltage Cable Plate ..... pg# 197

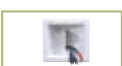

**IBA5-W:**  
 Recessed Low Voltage Media Plate with Duplex Surge Suppressor .. pg# 197

## TECHNICAL DRAWINGS

For expanded product information and technical data visit [www.peerless-av.com](http://www.peerless-av.com)

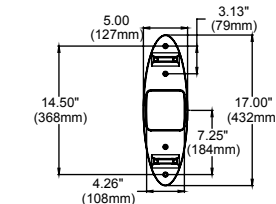

WALL PLATE

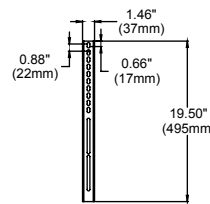

VERTICAL ADAPTER

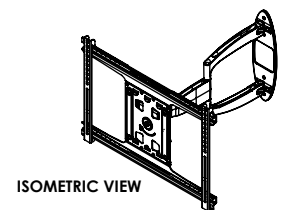

ISOMETRIC VIEW

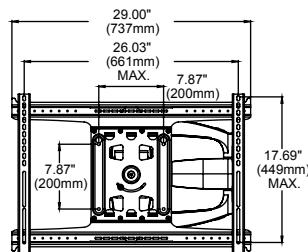

FRONT VIEW

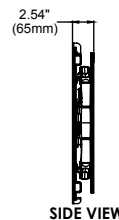

SIDE VIEW

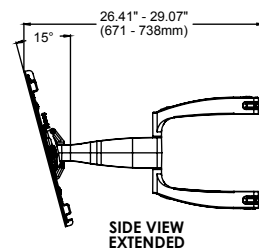

SIDE VIEW EXTENDED

To verify mount compatibility with any flat panel display or projector model use MountFinder™ at [www.peerless-av.com](http://www.peerless-av.com)



CALL: 630-375-5100  
 800-865-2112



FAX: 630-820-8537  
 800-359-6500



E-MAIL: [info@peerless-av.com](mailto:info@peerless-av.com)



ONLINE: [www.peerless-av.com](http://www.peerless-av.com)

# SMARTMOUNT Xt Articulating Wall Arm

For 40" to 63" Flat Panel Displays

1. Low-profile when retracted at 2.6" (66mm) and can extend up to 26.54" (674mm) from the wall
2. Internal cable management provides ample area to run cables to complete a clean, professional installation
3. Stylish wall plate covers create a finished look and are easy to install and remove
4. One-Touch™ tilt mechanism allows adjustment of +15/-5° without the use of tools
5. ±5° of roll for post-installation leveling
6. Display can be rotated from landscape to portrait without removing the display
7. ±0.5" (13mm) of vertical adjustment for post-installation height adjustment fine-tuning
8. Open wall plate design increases electrical and cable management options
9. Removable cover for wall plate knockout included

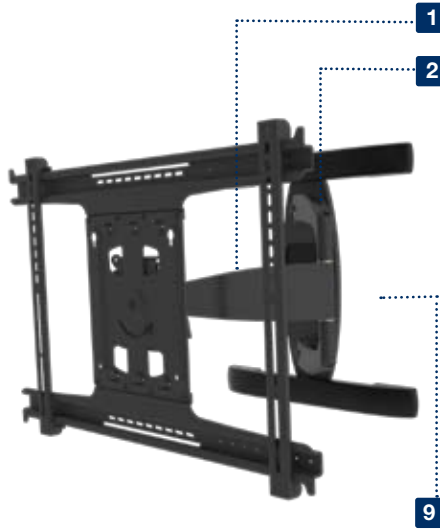

Optional Accessory ACCX400

Reseller Authorization Required



INTEGRATED PARTNER PROGRAM

For expanded product information and technical data visit [www.peerless-av.com](http://www.peerless-av.com)

## TECHNICAL DRAWINGS

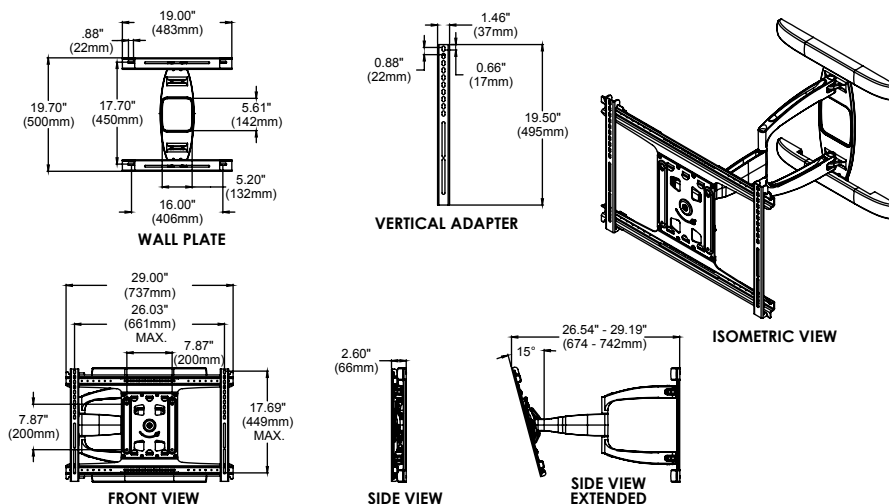

To verify mount compatibility with any flat panel display or projector model use MountFinder™ at [www.peerless-av.com](http://www.peerless-av.com)



CALL: 630-375-5100  
800-865-2112



FAX: 630-820-8537  
800-359-6500



E-MAIL: [info@peerless-av.com](mailto:info@peerless-av.com)



ONLINE: [www.peerless-av.com](http://www.peerless-av.com)



FLAT PANEL MOUNTS

## MODELS

### Universal Models:

Includes theft resistant hardware for attaching display to mount  
**SAX762PU** Ravens black

## DISPLAY ADAPTER



### Mounting Pattern

Universal Models: 661 x 449mm  
(26.03"W x 17.69"H)



### VESA® Pattern

Universal Models: Up to 600 x 400mm

## SPECIFICATIONS



### Distance from Wall

2.60"-26.54" (66-674mm)



### Tilt | Swivel | Roll

+15/-5° | ±90° | ±90°



### Max Load

110lb (50kg)



### Landscape to Portrait

Display can be rotated landscape to portrait without removing the display

### Product Dimensions (W x H x D)

29.00" x 19.5" x 2.60"-26.54"  
(737 x 495 x 66-674mm)

### Mounting Surfaces

Wood stud, concrete, cinder block and metal stud  
(Metal stud accessory required)

## CERTIFICATIONS



OSHPD Approval Pending

## ACCESSORIES



**ACC415:**  
4-pack Metal Stud Fastener Kit ..... pg# 196



**ACC955:**  
Component Shelf Accessory... pg#189



**ACCX100:**  
Left & Right Speaker Accessory Mount ..... pg# 189



**ACCX200:**  
Soundbar and Center Channel Accessory Mount..... pg# 189



**ACCX300:**  
Video Conferencing Shelf Accessory ..... pg# 189



**IBA4-W:**  
Easy Mount Recessed Low Voltage Cable Plate ..... pg# 197

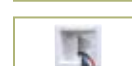

**IBA5-W:**  
Recessed Low Voltage Media Plate with Duplex Surge Suppressor .. pg# 197



**ACCX400:**  
Recessed Power Outlet with Low Voltage In-Wall Cable Routing.. pg# 189

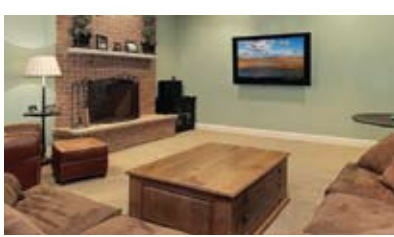

# SMARTMOUNT Xt Articulating Wall Arm

For 50" to 71" Flat Panel Displays

## MODELS

### Universal Models:

Includes theft resistant hardware for attaching display to mount  
**SAX772PU** Ravens black

## SCREEN ADAPTER

### Mounting Pattern

Universal Models: 813 x 607mm  
 (32.03"W x 23.91"H)

### VESA® Pattern

Universal Models: Up to 800 x 600mm

## SPECIFICATIONS

### Distance from Wall

2.60"-26.54" (66-674mm)

### Tilt | Swivel | Roll

+15/-5° | ±90° | ±90°

### Max Load

135lb (61.23kg)

### Landscape to Portrait

Display can be rotated landscape to portrait without removing the display

### Product Dimensions (W x H x D)

35.00" x 24.75" x 2.60"-26.54"  
 (889 x 629 x 66-674mm)

### Mounting Surfaces

Wood stud, concrete, cinder block and metal stud  
 (Metal stud accessory required)

1. Low-profile when retracted at 2.6" (66mm) and can extend up to 26.54" (674mm) from the wall
2. Internal cable management provides ample area to run cables to complete a clean, professional installation
3. Stylish wall plate covers create a finished look and are easy to install and remove
4. One-Touch™ tilt mechanism allows adjustment of +15/-5° without the use of tools
5. ±5° of roll for post-installation leveling
6. Display can be rotated from landscape to portrait without removing the display
7. ±0.5" (18mm) of vertical adjustment for post-installation height adjustment fine-tuning
8. Dual arms for a more robust installation
9. Open wall plate design increases electrical and cable management options
10. Removable cover for wall plate knockout included

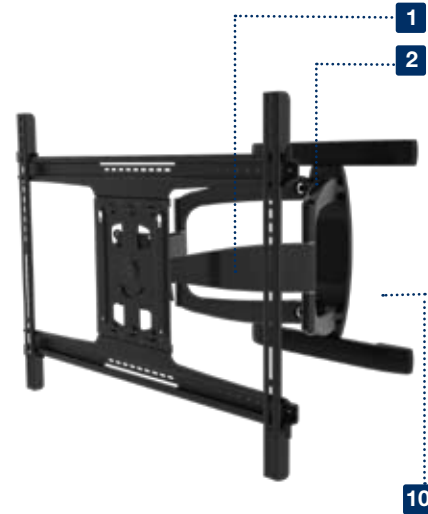

Optional Accessory ACCX400

Reseller Authorization Required



INTEGRATED PARTNER PROGRAM

## CERTIFICATIONS

UL US RoHS MADE IN USA OSHPD Approval Pending  
 Pending

## ACCESSORIES

- ACC415:** 4-pack Metal Stud Fastener Kit ..... pg# 196
- ACC955:** Component Shelf Accessory... pg#189
- ACCXT100:** Left & Right Speaker Accessory Mount ..... pg# 189
- ACCXT200:** Soundbar and Center Channel Accessory Mount..... pg# 189
- ACCXT300:** Video Conferencing Shelf Accessory ..... pg# 189
- IBA4-W:** Easy Mount Recessed Low Voltage Cable Plate ..... pg# 197
- IBA5-W:** Recessed Low Voltage Media Plate with Duplex Surge Suppressor .. pg# 197
- ACCXT400:** Recessed Power Outlet with Low Voltage In-Wall Cable Routing... pg# 189

## TECHNICAL DRAWINGS

For expanded product information and technical data visit [www.peerless-av.com](http://www.peerless-av.com)

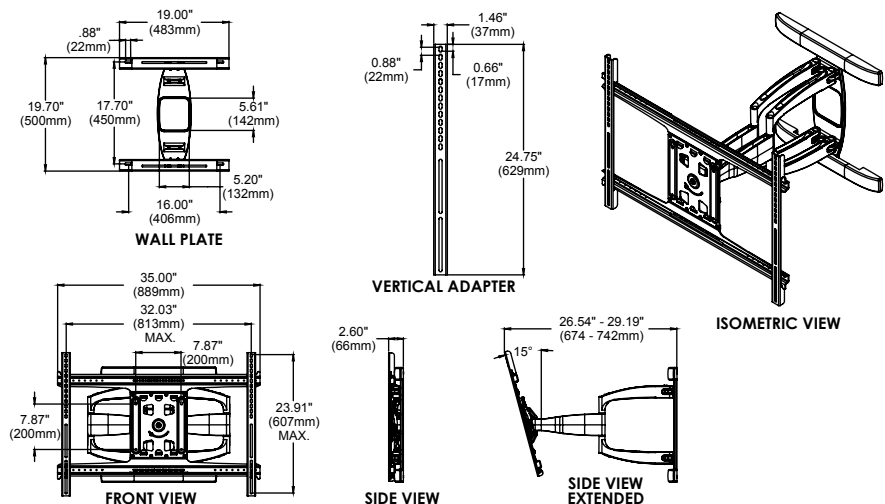

To verify mount compatibility with any flat panel display or projector model use MountFinder™ at [www.peerless-av.com](http://www.peerless-av.com)



CALL: 630-375-5100  
 800-865-2112



FAX: 630-820-8537  
 800-359-6500



E-MAIL: [info@peerless-av.com](mailto:info@peerless-av.com)



ONLINE: [www.peerless-av.com](http://www.peerless-av.com)

# SmartMount® Universal Flat Wall Mount

For 10" to 24" Flat Panel Displays

1. VESA® 75 and 100mm compliant
2. Non-VESA® display adapter plates also available
3. Low-profile design holds display 0.96" (24mm) away from the wall
4. Display adapter plate simply hooks onto wall plate for quick and easy installation



For expanded product information and technical data visit [www.peerless-av.com](http://www.peerless-av.com)

## TECHNICAL DRAWINGS

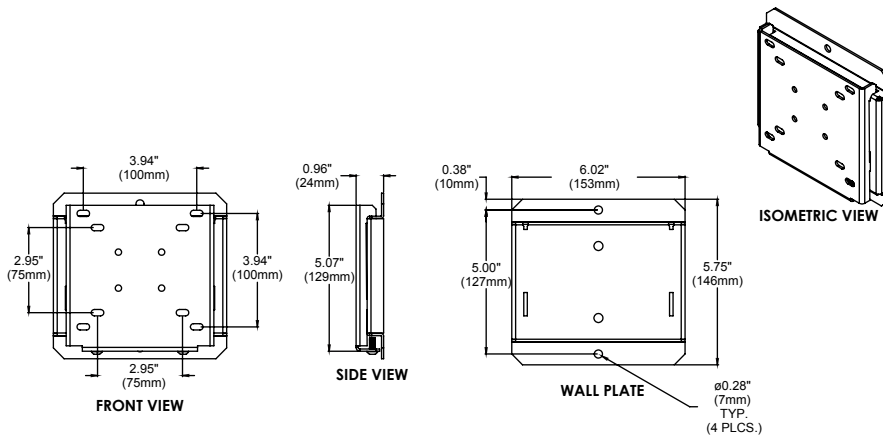

To verify mount compatibility with any flat panel display or projector model use MountFinder™ at [www.peerless-av.com](http://www.peerless-av.com)



CALL: 630-375-5100  
800-865-2112



FAX: 630-820-8537  
800-359-6500



E-MAIL: [info@peerless-av.com](mailto:info@peerless-av.com)



ONLINE: [www.peerless-av.com](http://www.peerless-av.com)



FLAT PANEL MOUNTS

## MODELS

### Universal Models:

Includes theft resistant hardware for attaching display to mount

**SF630** Black  
**SF630-S** Silver

Includes standard hardware (hex or Phillips) for attaching display to mount

**SF630P** Black  
**SF630P-S** Silver

## DISPLAY ADAPTER



### VESA® Pattern

Universal Models: 75 and 100mm

## SPECIFICATIONS



### Distance from Wall

0.96" (24mm)



### Max Load

80lb (36kg)

### Product Dimensions (W x H x D)

6.02" x 5.75" x 0.96"  
(153 x 146 x 24mm)

### Mounting Surfaces

Wood stud, concrete, cinder block and metal stud  
(Metal stud accessory required)

### Ship Weight

2.5lb (1.13kg)

## CERTIFICATIONS



OSHPD Approval Pending

## ACCESSORIES



**ACC215:**  
2-pack Metal Stud  
Fastener Kit ..... pg# 196



**IBA4-W:**  
Easy Mount Recessed  
Low Voltage Cable Plate ..... pg# 197



**IBA5-W:**  
Recessed Low Voltage  
Media Plate with Duplex  
Surge Suppressor ..... pg# 197



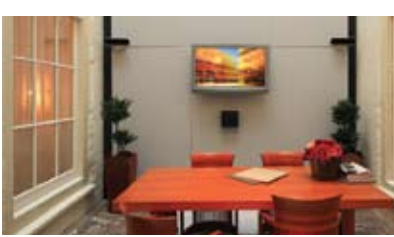

# SmartMount® Universal Flat Wall Mount

For 22" to 40" Flat Panel Displays

## MODELS

### Universal Models:

Includes theft resistant hardware for attaching display to mount

**SF632** Black  
**SF632-S** Silver

Includes standard hardware (hex or Phillips) for attaching display to mount

**SF632P** Black  
**SF632P-S** Silver

## DISPLAY ADAPTER

### VESA® Pattern

Universal Models: 75, 100, 200 x 100 and 200 x 200mm

## SPECIFICATIONS

### Distance from Wall

1.02" (26mm)

### Max Load

115lb (52kg)

### Product Dimensions (W x H x D)

8.75" x 9.35" x 1.02"  
(222 x 237 x 26mm)

### Mounting Surfaces

Wood stud, concrete, cinder block and metal stud  
(Metal stud accessory required)

### Ship Weight

4lb (1.81kg)

## CERTIFICATIONS



OSHDP Approval Pending

## ACCESSORIES

**ACC215:**  
2-pack Metal Stud Fastener Kit ..... pg# 196

**IBA4-W:**  
Easy Mount Recessed Low Voltage Cable Plate ..... pg# 197

**IBA5-W:**  
Recessed Low Voltage Media Plate with Duplex Surge Suppressor ..... pg# 197

1. VESA® 75, 100, 200 x 100 and 200 x 200mm compliant
2. Non-VESA® display adapter plates also available
3. Low-profile design holds display 1.02" (26mm) away from the wall
4. Display adapter plate simply hooks onto wall plate for quick and easy installation
4. Compatible with flat panels that use M8 screws

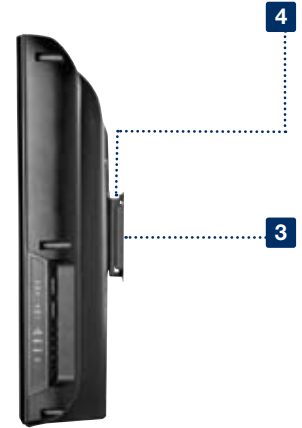

## TECHNICAL DRAWINGS

For expanded product information and technical data visit [www.peerless-av.com](http://www.peerless-av.com)

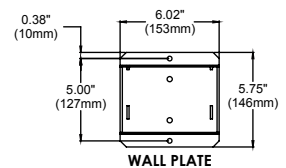
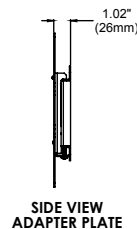
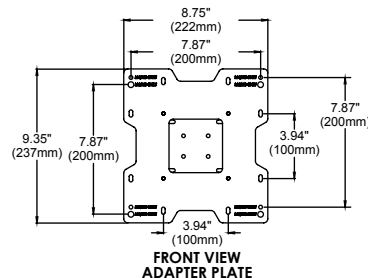
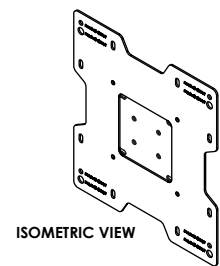
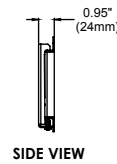
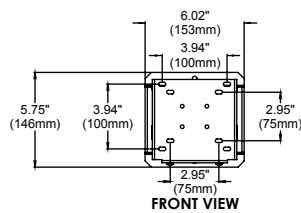

To verify mount compatibility with any flat panel display or projector model use MountFinder™ at [www.peerless-av.com](http://www.peerless-av.com)

CALL: 630-375-5100  
800-865-2112

FAX: 630-820-8537  
800-359-6500

E-MAIL: [info@peerless-av.com](mailto:info@peerless-av.com)

ONLINE: [www.peerless-av.com](http://www.peerless-av.com)

# SmartMount® Universal Flat Wall Mount

For 23" to 46" Flat Panel Displays

1. Open wall plate design allows for total wall access, increasing electrical and cable management options
2. Low-profile design holds display only 1.2" (30mm) from the wall
3. Easy-Glide™ design ensures display is securely attached to wall plate
4. Horizontal display adjustment up to 6" (152mm) for centering display on wall
5. Universal display adapters easily hook onto wall plate for fast installation
6. Fits displays with mounting hole patterns up to 450 x 329mm (17.73"W x 12.94"H)



For expanded product information and technical data visit [www.peerless-av.com](http://www.peerless-av.com)

## TECHNICAL DRAWINGS

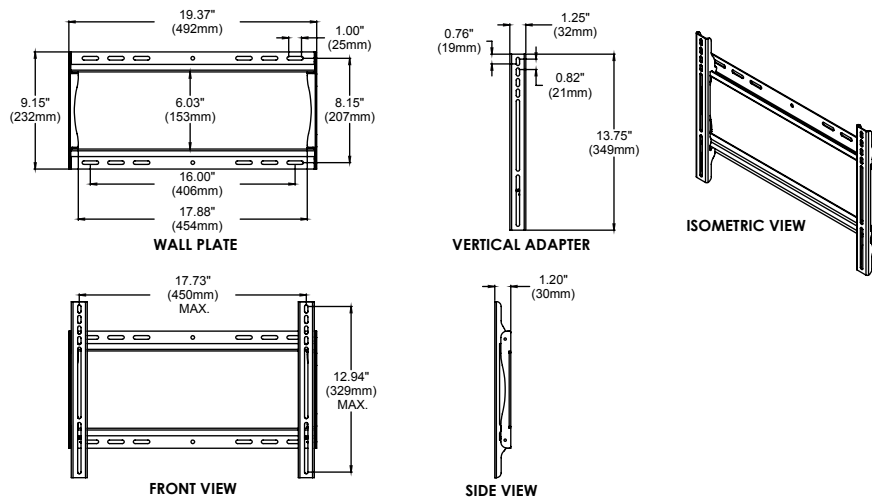

FLAT PANEL MOUNTS

## MODELS

### Universal Models:

Includes theft resistant hardware for attaching display to mount

**SF640** Black  
**SF640-S** Silver

Includes standard hardware (hex or Phillips) for attaching display to mount

**SF640P** Black  
**SF640P-S** Silver

## DISPLAY ADAPTER



### Mounting Pattern

Universal Models: 450 x 329mm  
(17.73"W x 12.94"H)

Many 42" flat panel displays have mounting hole patterns larger than dimensions above. Use MountFinder™ to verify mount compatibility.



### VESA® Pattern

Universal Models: Up to 400 x 300mm

## SPECIFICATIONS



### Distance from Wall

1.20" (30mm)



### Max Load

150lb (68kg)

### Product Dimensions (W x H x D)

19.37" x 13.75" x 1.20"  
(492 x 349 x 30mm)

### Mounting Surfaces

Wood stud, concrete, cinder block and metal stud  
(Metal stud accessory required)

### Ship Weight

5.7lb (2.58kg)

## CERTIFICATIONS



## ACCESSORIES



**ACC415:**  
4-pack Metal Stud Fastener Kit ..... pg# 196



**ACC309:**  
Video Conference Shelf ..... pg# 166



**IBA4-W:**  
Easy Mount Recessed Low Voltage Cable Plate ..... pg# 197

To verify mount compatibility with any flat panel display or projector model use MountFinder™ at [www.peerless-av.com](http://www.peerless-av.com)



CALL: 630-375-5100  
800-865-2112



FAX: 630-820-8537  
800-359-6500



E-MAIL:  
[info@peerless-av.com](mailto:info@peerless-av.com)



ONLINE:  
[www.peerless-av.com](http://www.peerless-av.com)

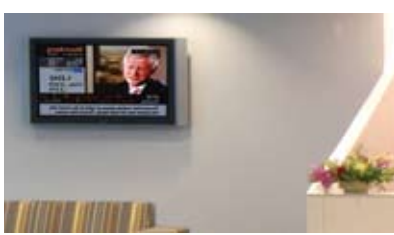

# SmartMount® Universal Flat Wall Mount

For 32" to 56" Flat Panel Displays

## MODELS

### Universal Models:

Includes theft resistant hardware for attaching display to mount

**SF650** Black  
**SF650-S** Silver

Includes standard hardware (hex or Phillips) for attaching display to mount

**SF650P** Black  
**SF650P-S** Silver

## DISPLAY ADAPTER



### Mounting Pattern

Universal Models: 742 x 433mm  
(29.23"W x 17.05"H)



### VESA® Pattern

Universal Models: Up to 600 x 400mm

## SPECIFICATIONS



### Distance from Wall

1.70" (43mm)



### Max Load

175lb (79kg)

### Product Dimensions (W x H x D)

30.87" x 18.00" x 1.70"  
(784 x 457 x 43mm)

### Mounting Surfaces

Wood stud, concrete, cinder block and metal stud  
(Metal stud accessory required)

### Ship Weight

8lb (3.62kg)

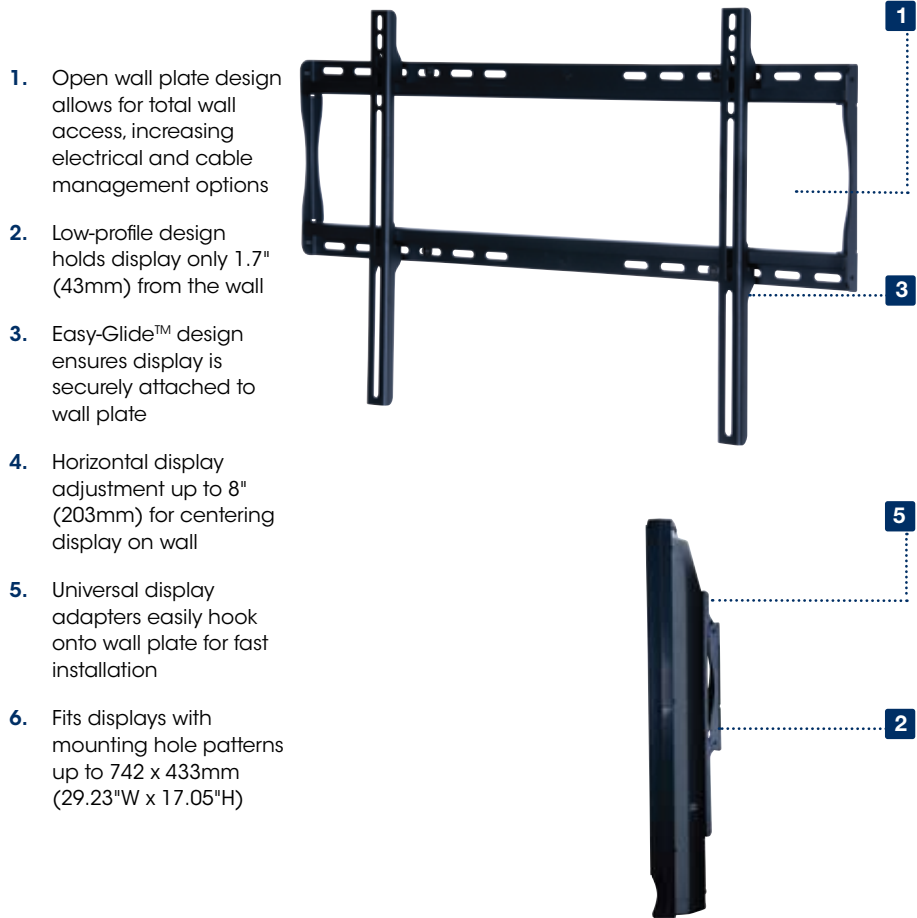

1. Open wall plate design allows for total wall access, increasing electrical and cable management options
2. Low-profile design holds display only 1.7" (43mm) from the wall
3. Easy-Glide™ design ensures display is securely attached to wall plate
4. Horizontal display adjustment up to 8" (203mm) for centering display on wall
5. Universal display adapters easily hook onto wall plate for fast installation
6. Fits displays with mounting hole patterns up to 742 x 433mm (29.23"W x 17.05"H)

## TECHNICAL DRAWINGS

For expanded product information and technical data visit [www.peerless-av.com](http://www.peerless-av.com)

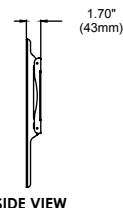
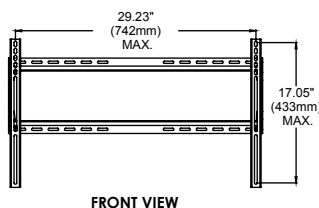
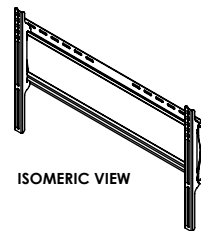
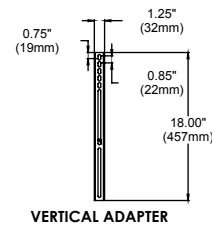
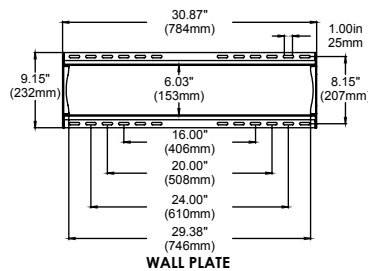

## CERTIFICATIONS



## ACCESSORIES



**ACC415:**  
4-pack Metal Stud Fastener Kit ..... pg# 196



**ACC309:**  
Video Conference Shelf ..... pg# 166



**IBA4-W:**  
Easy Mount Recessed Low Voltage Cable Plate ..... pg# 197

To verify mount compatibility with any flat panel display or projector model use MountFinder™ at [www.peerless-av.com](http://www.peerless-av.com)



CALL: 630-375-5100  
800-865-2112



FAX: 630-820-8537  
800-359-6500



E-MAIL: [info@peerless-av.com](mailto:info@peerless-av.com)



ONLINE: [www.peerless-av.com](http://www.peerless-av.com)

# SmartMount® Universal Flat Wall Mount

For 37" to 63" Flat Panel Displays



FLAT PANEL MOUNTS

1. Open wall plate design allows for total wall access, increasing electrical and cable management options
2. Easy-Glide™ design ensures display is securely attached to wall plate
3. Horizontal display adjustment up to 8" (203mm) for centering display on wall
4. Universal display adapters easily hook onto wall plate for fast installation
5. Fits displays with mounting hole patterns up to 825 x 433mm (32.48"W x 17.05"H), including VESA® 800 x 400mm

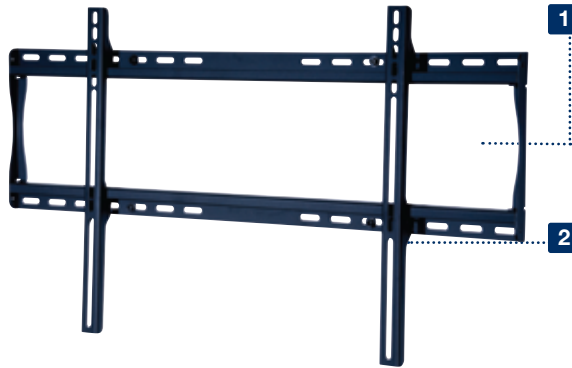

For expanded product information and technical data visit [www.peerless-av.com](http://www.peerless-av.com)

## TECHNICAL DRAWINGS

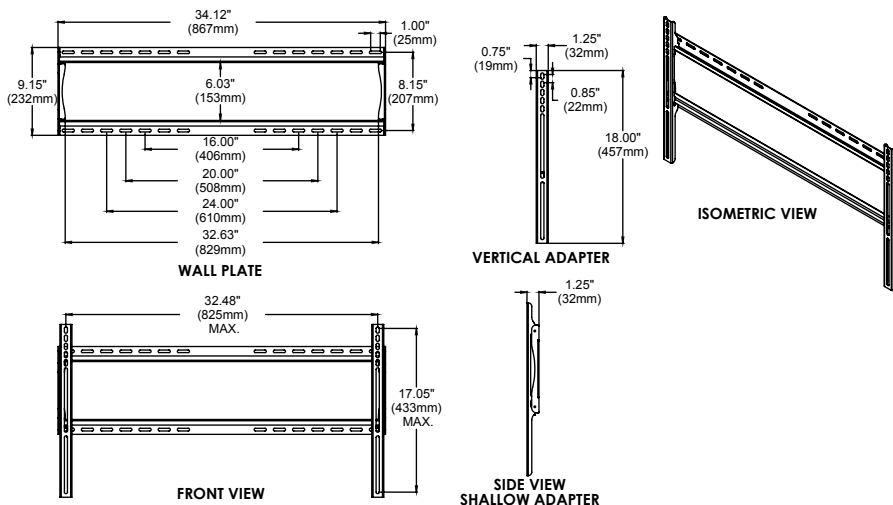

## MODELS

### Universal Models:

Includes theft resistant hardware for attaching display to mount

**SF660** Black  
**SF660-S** Silver

Includes standard hardware (hex or Phillips) for attaching display to mount

**SF660P** Black  
**SF660P-S** Silver

## DISPLAY ADAPTER



### Mounting Pattern

Universal Models: 825 x 433mm  
(32.48"W x 17.05"H)



### VESA® Pattern

Universal Models: Up to 800 x 400mm

## SPECIFICATIONS



### Distance from Wall

1.25" (32mm)



### Max Load

200lb (90kg)

### Product Dimensions (W x H x D)

34.12" x 18.00" x 1.25"  
(867 x 457 x 32mm)

### Mounting Surfaces

Wood stud, concrete, cinder block and metal stud  
(Metal stud accessory required)

### Ship Weight

9.4lb (4.26kg)

## CERTIFICATIONS



## ACCESSORIES



**ACC415:**  
4-pack Metal Stud Fastener Kit ..... pg# 196



**ACC309:**  
Video Conference Shelf ..... pg# 166



**IBA4-W:**  
Easy Mount Recessed Low Voltage Cable Plate ..... pg# 197

To verify mount compatibility with any flat panel display or projector model use MountFinder™ at [www.peerless-av.com](http://www.peerless-av.com)



CALL: 630-375-5100  
800-865-2112



FAX: 630-820-8537  
800-359-6500



E-MAIL:  
[info@peerless-av.com](mailto:info@peerless-av.com)



ONLINE:  
[www.peerless-av.com](http://www.peerless-av.com)



# SmartMount® Universal Flat Wall Mount

For 42" to 71" Flat Panel Displays

## MODELS

### Universal Models:

Includes theft resistant hardware for attaching display to mount

**SF670** Black  
**SF670-S** Silver

Includes standard hardware (hex or Phillips) for attaching display to mount

**SF670P** Black  
**SF670P-S** Silver

## DISPLAY ADAPTER



### Mounting Pattern

Universal Models: 908 x 503mm  
(35.75"W x 19.79"H)

## SPECIFICATIONS



### Distance from Wall

1.73" (44mm)



### Max Load

250lb (113kg)

### Product Dimensions (W x H x D)

37.75" x 20.63" x 1.73"  
(959 x 524 x 44mm)

### Mounting Surfaces

Wood stud, concrete, cinder block and metal stud  
(Metal stud accessory required)

### Ship Weight

13.1lb (5.94kg)

## CERTIFICATIONS



\* With max load up to 200lb (90kg)

## ACCESSORIES



**ACC615:**  
6-pack Metal Stud  
Fastener Kit ..... pg# 196



**ACC309:**  
Video Conference Shelf ..... pg# 166



**IBA4-W:**  
Easy Mount Recessed  
Low Voltage Cable Plate ..... pg# 197

1. Low-profile design holds display only 1.73" (44mm) from the wall
2. Horizontal display adjustment up to 12" (304mm) for centering display on wall
3. Easy-Glide™ design ensures display is securely attached to wall plate
4. Universal display adapters easily hook onto wall plate for fast installation
5. Fits displays with mounting hole patterns up to 908 x 503mm (35.75"W x 19.79"H)
6. Wall plate knockouts provide wall access, improving cable management options

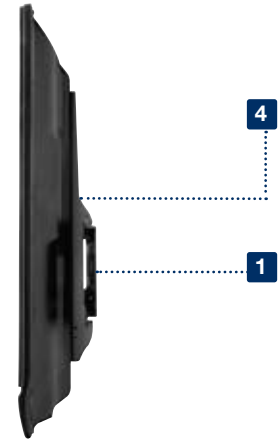
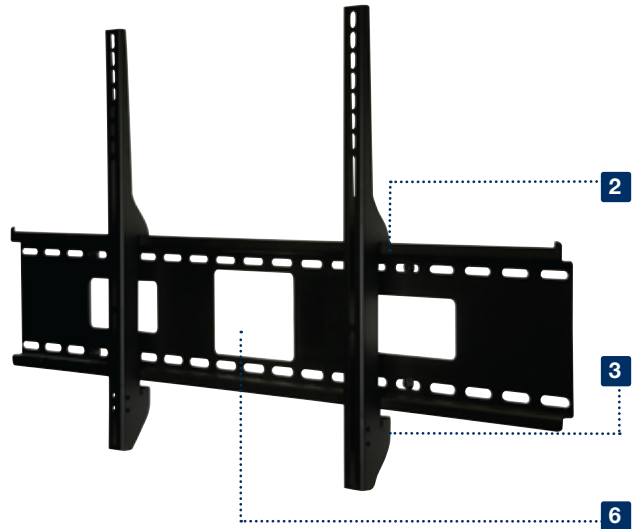

## TECHNICAL DRAWINGS

For expanded product information and technical data visit [www.peerless-av.com](http://www.peerless-av.com)

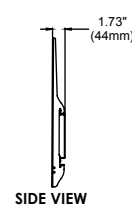
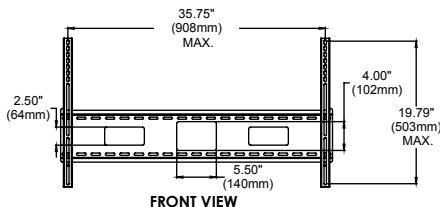
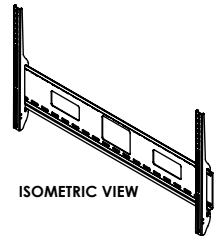
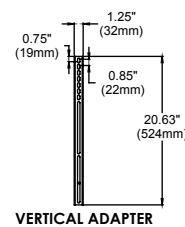
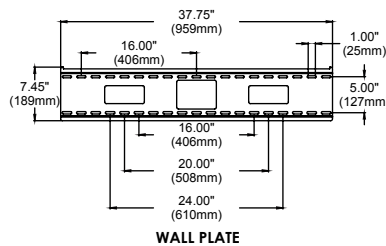

To verify mount compatibility with any flat panel display or projector model use MountFinder™ at [www.peerless-av.com](http://www.peerless-av.com)



CALL: 630-375-5100  
800-865-2112



FAX: 630-820-8537  
800-359-6500



E-MAIL: [info@peerless-av.com](mailto:info@peerless-av.com)



ONLINE: [www.peerless-av.com](http://www.peerless-av.com)



# SmartMount® Universal Flat Wall Mount

For 61" to 102" Flat Panel Displays



FLAT PANEL MOUNTS

1. Low-profile design holds display only 1.83" (46mm) from the wall
2. Horizontal display adjustment up to 12" (304mm) for centering display on wall
3. Safety latch ensures display is securely attached to wall plate
4. Universal display adapters easily hook onto wall plate for fast installation
5. Fits displays with mounting hole patterns up to 1111 x 745mm (43.75"W x 29.31"H)
6. Wall plate knockouts provide wall access, improving cable management options
7. Supports M10 mounting bolts

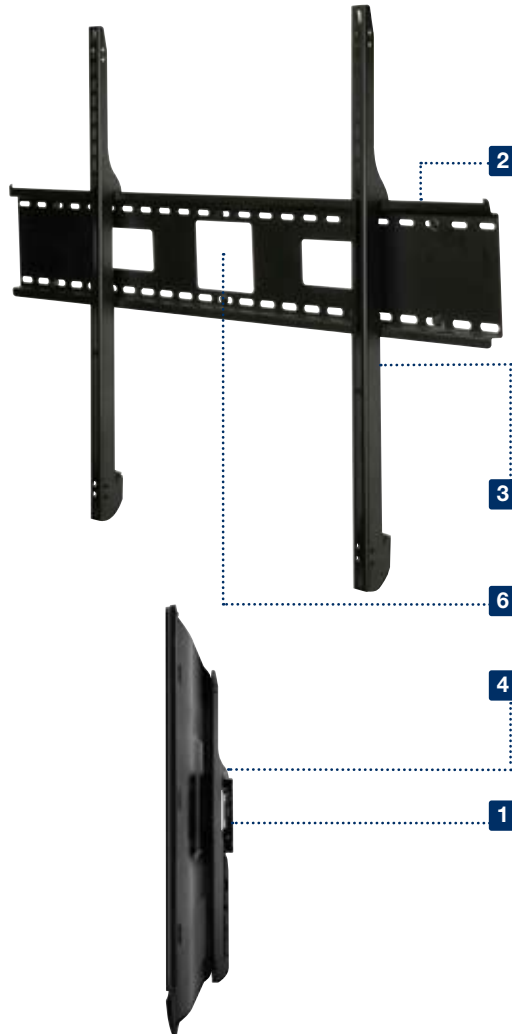

For expanded product information and technical data visit [www.peerless-av.com](http://www.peerless-av.com)

## TECHNICAL DRAWINGS

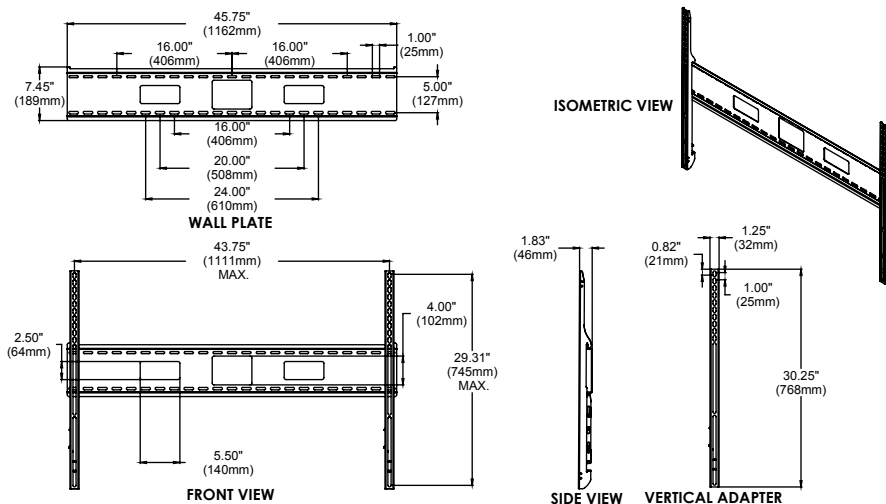

## MODELS

### Universal Models:

Includes theft resistant hardware for attaching display to mount

**SF680** Black  
**SF680-S** Silver

Includes standard hardware (hex or Phillips) for attaching display to mount

**SF680P** Black  
**SF680P-S** Silver

## DISPLAY ADAPTER



### Mounting Pattern

Universal Models: 1111 x 745mm (43.75"W x 29.31"H)

## SPECIFICATIONS



### Distance from Wall

1.83" (46mm)



### Max Load

350lb (158kg)

### Product Dimensions (W x H x D)

45.75" x 30.25" x 1.83" (1162 x 768 x 46mm)

### Mounting Surfaces

Wood stud, concrete, cinder block and metal stud (Metal stud accessory required)

### Ship Weight

16.5lb (7.48kg)

## CERTIFICATIONS



\*With max load up to 200lb (90kg)

## ACCESSORIES



**ACC615:**  
6-pack Metal Stud Fastener Kit ..... pg# 196



**ACC309:**  
Video Conference Shelf ..... pg# 166



**IBA4-W:**  
Easy Mount Recessed Low Voltage Cable Plate ..... pg# 197

To verify mount compatibility with any flat panel display or projector model use MountFinder™ at [www.peerless-av.com](http://www.peerless-av.com)



CALL: 630-375-5100  
800-865-2112



FAX: 630-820-8537  
800-359-6500



E-MAIL:  
[info@peerless-av.com](mailto:info@peerless-av.com)



ONLINE:  
[www.peerless-av.com](http://www.peerless-av.com)

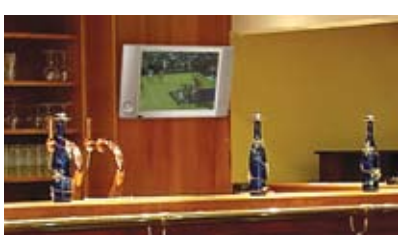

# SmartMount® Universal Tilt Wall Mount

For 10" to 24" Flat Panel Displays

## MODELS

### Universal Models:

Includes theft resistant hardware for attaching display to mount

**ST630** Black  
**ST630-S** Silver

Includes standard hardware (hex or Phillips) for attaching display to mount

**ST630P** Black  
**ST630P-S** Silver

## DISPLAY ADAPTER

### VESA® Pattern

Universal Models: 75 and 100mm

## SPECIFICATIONS

**Distance from Wall**  
1.58"-2.23" (40-57mm)

**Tilt**  
+15/-5°

**Max Load**  
80lb (36kg)

**Product Dimensions (W x H x D)**  
6.61" x 6.20" x 1.58"-2.23"  
(168 x 157 x 40-57mm)

**Mounting Surfaces**  
Wood stud, concrete, cinder block and metal stud  
(Metal stud accessory required)

**Ship Weight**  
2.9lb (1.31kg)

1. VESA® 75 and 100mm compliant
2. Non-VESA® display adapter plates also available
3. Up to +15/-5° of tilt without the use of tools
4. Display adapter plate simply hooks onto wall plate for quick and easy installation



Patented

## CERTIFICATIONS



OSHDP Approval Pending

## ACCESSORIES

**ACC215:**  
2-pack Metal Stud Fastener Kit ..... pg# 196

**IBA4-W:**  
Easy Mount Recessed Low Voltage Cable Plate ..... pg# 197

**IBA5-W:**  
Recessed Low Voltage Media Plate with Duplex Surge Suppressor ..... pg# 197

## TECHNICAL DRAWINGS

For expanded product information and technical data visit [www.peerless-av.com](http://www.peerless-av.com)

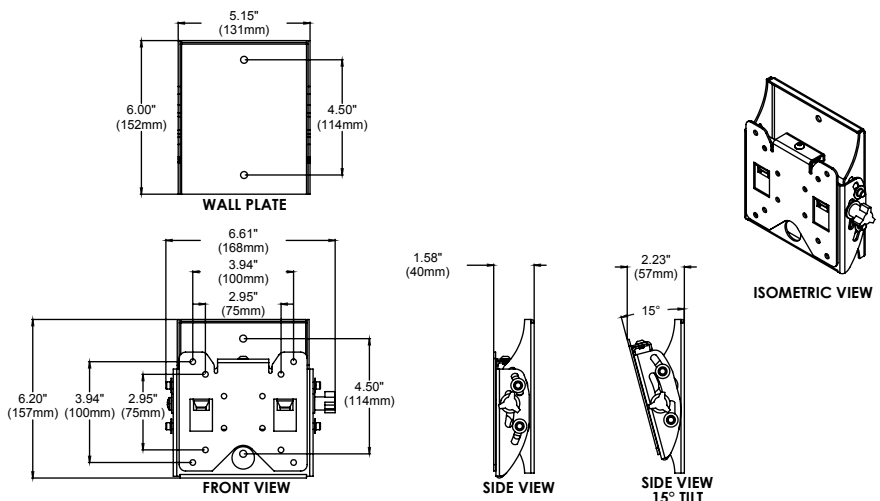

To verify mount compatibility with any flat panel display or projector model use MountFinder™ at [www.peerless-av.com](http://www.peerless-av.com)

# SmartMount® Universal Tilt Wall Mount

For 22" to 40" Flat Panel Displays



FLAT PANEL MOUNTS

1. VESA® 75, 100, 200 x 100 and 200 x 200mm compliant
2. Non-VESA® display adapter plates also available
3. Up to +15/-5° of tilt without the use of tools
4. Display adapter plate simply hooks onto wall plate for quick and easy installation
5. Compatible with flat panels that use M8 screws

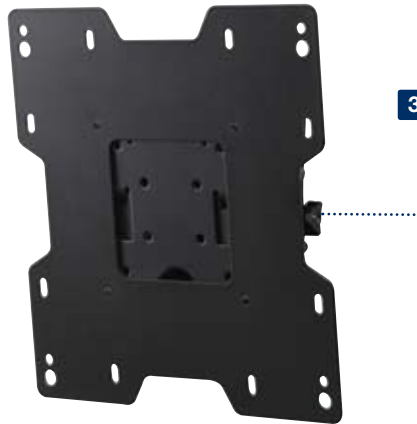

Patented

For expanded product information and technical data visit [www.peerless-av.com](http://www.peerless-av.com)

## TECHNICAL DRAWINGS

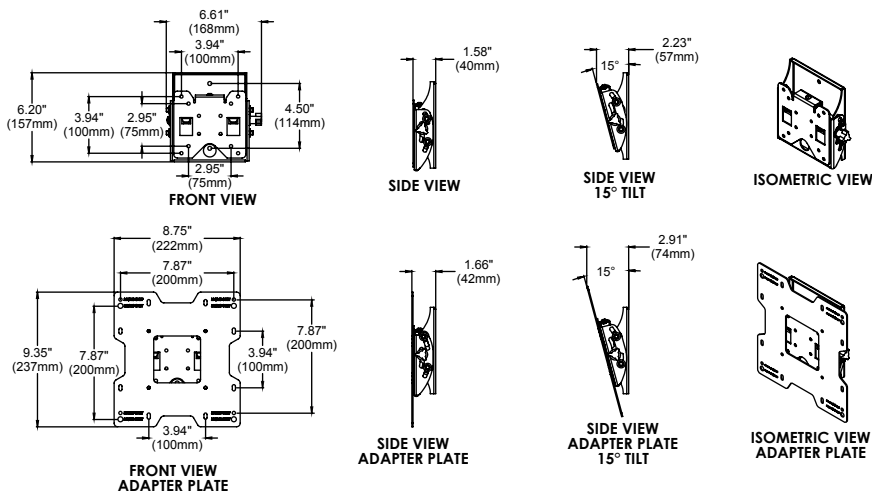

## MODELS

### Universal Models:

Includes theft resistant hardware for attaching display to mount	
<b>ST632</b>	Black
<b>ST632-S</b>	Silver
Includes standard hardware (hex or Phillips) for attaching display to mount	
<b>ST632P</b>	Black
<b>ST632P-S</b>	Silver

## DISPLAY ADAPTER



### VESA® Pattern

Universal Models:	75, 100, 200 x 100 and 200 x 200mm
-------------------	------------------------------------

## SPECIFICATIONS



### Distance from Wall

1.66" -2.91" (42 -74mm)



### Tilt

+15/-5°



### Max Load

115lb (52kg)

### Product Dimensions (W x H x D)

8.75" x 9.35" x 1.66" -2.91"  
(222 x 237 x 42 -74mm)

### Mounting Surfaces

Wood stud, concrete, cinder block and metal stud  
(Metal stud accessory required)

### Ship Weight

4.4lb (1.99kg)

## CERTIFICATIONS



OSHPD Approval Pending

## ACCESSORIES



**ACC215:**  
2-pack Metal Stud Fastener Kit ..... pg# 196



**IBA4-W:**  
Easy Mount Recessed Low Voltage Cable Plate ..... pg# 197



**IBA5-W:**  
Recessed Low Voltage Media Plate with Duplex Surge Suppressor ..... pg# 197

To verify mount compatibility with any flat panel display or projector model use MountFinder™ at [www.peerless-av.com](http://www.peerless-av.com)



CALL: 630-375-5100  
800-865-2112



FAX: 630-820-8537  
800-359-6500



E-MAIL: [info@peerless-av.com](mailto:info@peerless-av.com)



ONLINE: [www.peerless-av.com](http://www.peerless-av.com)

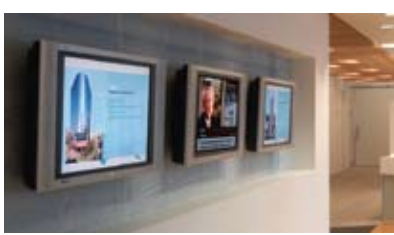

# SmartMount® Universal Tilt Wall Mount

For 13" to 37" Flat Panel Displays

## MODELS

### Universal Models:

Includes theft resistant hardware for attaching display to mount

**ST635** Black  
**ST635-S** Silver

Includes standard hardware (hex or Phillips) for attaching display to mount

**ST635P** Black  
**ST635P-S** Silver

## DISPLAY ADAPTER



### Mounting Pattern

Universal Models: 245 x 241mm  
(9.65"W x 9.48"H)



### VESA® Pattern

Universal Models: 75, 100, 200 x 100 and 200 x 200mm

## SPECIFICATIONS



### Distance from Wall

2.63"-4.38" (67-111mm)



### Tilt

+15/-5°



### Max Load

125lb (56kg)

### Product Dimensions (W x H x D)

13.77" x 10.30" x 2.63"-4.38"  
(350 x 262 x 67-111mm)

### Mounting Surfaces

Wood stud, concrete, cinder block and metal stud  
(Metal stud accessory required)

### Ship Weight

6.6lb (2.99kg)

## CERTIFICATIONS



OSHDP Approval Pending

## ACCESSORIES



**ACC415:**  
4-pack Metal Stud  
Fastener Kit ..... pg# 196



**IBA4-W:**  
Easy Mount Recessed  
Low Voltage Cable Plate ..... pg# 197

1. Open wall plate design allows for total wall access, increasing electrical and cable management options
2. Included IncreLok™ feature offers fixed tilt lock in 5° increments when used
3. Easy-Grip™ ratcheting handle locks tilt angle into place
4. Universal display adapters easily hook onto wall plate for fast installation
5. Fits displays with mounting hole patterns up to 245 x 241 mm (9.65"W x 9.48"H), including VESA® 75, 100, 200 x 100, and 200 x 200mm

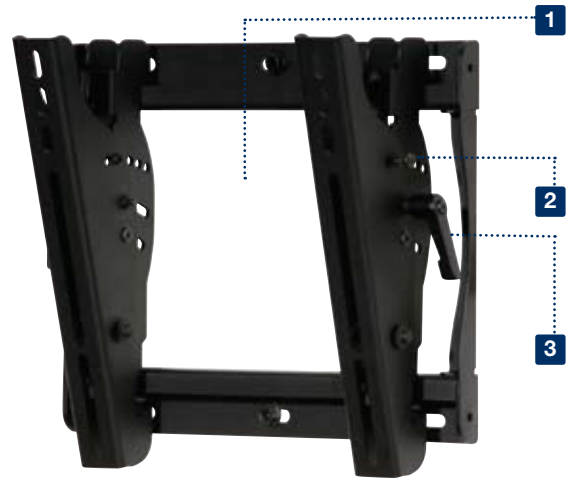

Patented

## TECHNICAL DRAWINGS

For expanded product information and technical data visit [www.peerless-av.com](http://www.peerless-av.com)

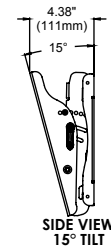
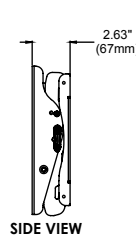
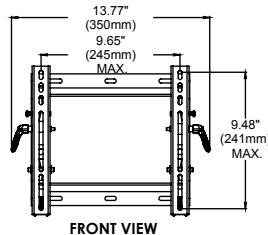
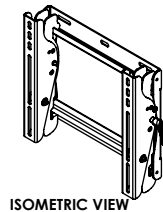
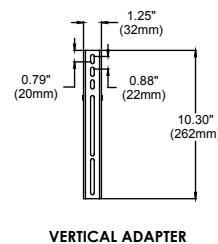
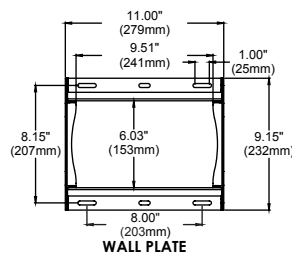

To verify mount compatibility with any flat panel display or projector model use MountFinder™ at [www.peerless-av.com](http://www.peerless-av.com)



CALL: 630-375-5100  
800-865-2112



FAX: 630-820-8537  
800-359-6500



E-MAIL: [info@peerless-av.com](mailto:info@peerless-av.com)



ONLINE: [www.peerless-av.com](http://www.peerless-av.com)

# SmartMount® Universal Tilt Wall Mount

For 23" to 46" Flat Panel Displays

1. Open wall plate design allows for total wall access, increasing electrical and cable management options

2. Included IncreLok™ feature offers fixed tilt lock in 5° increments when used

3. Easy-Grip™ ratcheting handle locks tilt angle into place

4. Universal tilt adapters allow for +15/-5° tilt adjustment in one easy motion

5. Horizontal display adjustment up to 6" (152mm) for centering display on wall

6. Universal display adapters easily hook onto wall plate for fast installation

7. Fits displays with mounting hole patterns up to 458 x 329mm (18.02"W x 12.94"H)



Patented

For expanded product information and technical data visit [www.peerless-av.com](http://www.peerless-av.com)

## TECHNICAL DRAWINGS

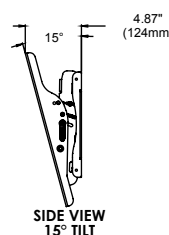
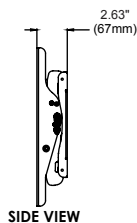
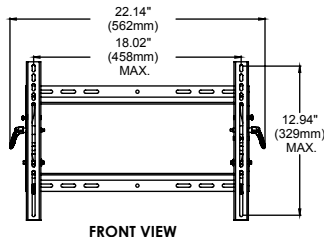
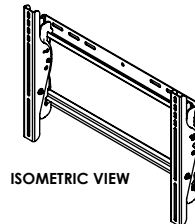
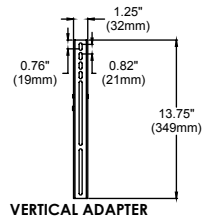
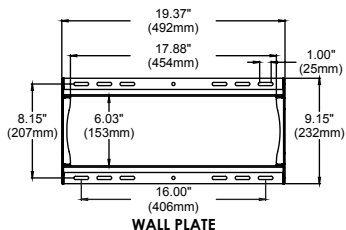

To verify mount compatibility with any flat panel display or projector model use MountFinder™ at [www.peerless-av.com](http://www.peerless-av.com)



CALL: 630-375-5100  
800-865-2112



FAX: 630-820-8537  
800-359-6500



E-MAIL: [info@peerless-av.com](mailto:info@peerless-av.com)



ONLINE: [www.peerless-av.com](http://www.peerless-av.com)



FLAT PANEL MOUNTS

## MODELS

### Universal Models:

Includes theft resistant hardware for attaching display to mount

**ST640** Black  
**ST640-S** Silver

Includes standard hardware (hex or Phillips) for attaching display to mount

**ST640P** Black  
**ST640P-S** Silver

## DISPLAY ADAPTER



### Mounting Pattern

Universal Models: 458 x 329mm  
(18.02"W x 12.94"H)

Many 42" flat panel displays have mounting hole patterns larger than dimensions above. Use MountFinder™ to verify mount compatibility.



### VESA® Pattern

Universal Models: Up to 400 x 300mm

## SPECIFICATIONS



### Distance from Wall

2.63"-4.87" (67-124mm)



### Tilt

+15/-5°



### Max Load

150lb (68kg)

### Product Dimensions (W x H x D)

22.14" x 13.75" x 2.63"-4.87"  
(562 x 349 x 67-124mm)

### Mounting Surfaces

Wood stud, concrete, cinder block and metal stud  
(Metal stud accessory required)

### Ship Weight

8.5lb (3.85kg)

## CERTIFICATIONS



## ACCESSORIES



**ACC415:**  
4-pack Metal Stud Fastener Kit ..... pg# 197



**ACC309:**  
Video Conference Shelf ..... pg# 167



**IBA4-W:**  
Easy Mount Recessed Low Voltage Cable Plate ..... pg# 197



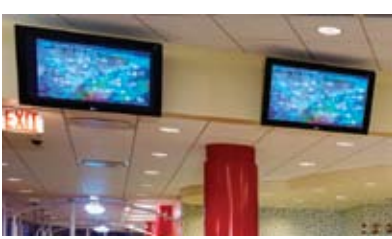

# SmartMount® Universal Tilt Wall Mount

For 32" to 56" Flat Panel Displays

## MODELS

### Universal Models:

Includes theft resistant hardware for attaching display to mount

**ST650** Black  
**ST650-S** Silver

Includes standard hardware (hex or Phillips) for attaching display to mount

**ST650P** Black  
**ST650P-S** Silver

## DISPLAY ADAPTER



### Mounting Pattern

Universal Models: 750 x 449mm  
(29.52"W x 17.67"H)



### VESA® Pattern

Universal Models: Up to 600 x 400mm

## SPECIFICATIONS



### Distance from Wall

2.63"-5.71" (67-145mm)



### Tilt

+15/-5°



### Max Load

175 lb (79kg)

### Product Dimensions (W x H x D)

33.64" x 18.50" x 2.63"-5.71"  
(854 x 470 x 67-145mm)

### Mounting Surfaces

Wood stud, concrete, cinder block and metal stud  
(Metal stud accessory required)

### Ship Weight

10.5lb (4.76kg)

## CERTIFICATIONS



## ACCESSORIES



**ACC415:**  
4-pack Metal Stud  
Fastener Kit ..... pg# 196



**ACC309:**  
Video Conference Shelf ..... pg# 166



**IBA4-W:**  
Easy Mount Recessed  
Low Voltage Cable Plate ..... pg# 197

1. Open wall plate design allows for total wall access, increasing electrical and cable management options
2. Universal tilt adapters allow for +15/-5° tilt adjustment in one easy motion
3. Included IncreLoK™ feature offers fixed tilt lock in 5° increments when used
4. Easy-Grip™ ratcheting handle locks tilt angle into place
5. Horizontal display adjustment up to 8" (203mm) for centering display on wall
6. Universal display adapters easily hook onto wall plate for fast installation
7. Fits displays with mounting hole patterns: 750 x 449mm (29.52"W x 17.67"H)



Patented

## TECHNICAL DRAWINGS

For expanded product information and technical data visit [www.peerless-av.com](http://www.peerless-av.com)

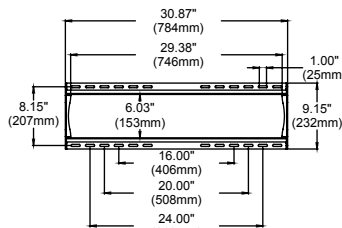

WALL PLATE

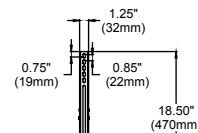

VERTICAL ADAPTER

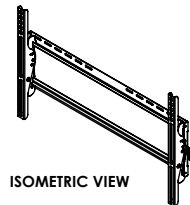

ISOMETRIC VIEW

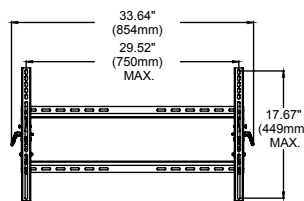

FRONT VIEW

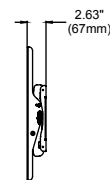

SIDE VIEW

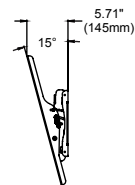

SIDE VIEW  
15° TILT

To verify mount compatibility with any flat panel display or projector model use MountFinder™ at [www.peerless-av.com](http://www.peerless-av.com)



CALL: 630-375-5100  
800-865-2112



FAX: 630-820-8537  
800-359-6500



E-MAIL:  
[info@peerless-av.com](mailto:info@peerless-av.com)



ONLINE:  
[www.peerless-av.com](http://www.peerless-av.com)

# SmartMount® Universal Tilt Wall Mount

For 37" to 63" Flat Panel Displays

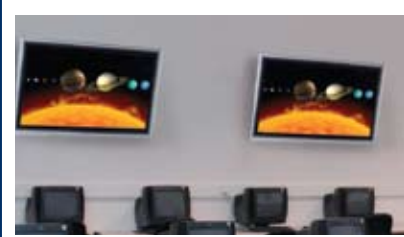

FLAT PANEL MOUNTS

1. Open wall plate design allows for total wall access, increasing electrical and cable management options
2. Universal tilt adapters allow for +15/-5° tilt adjustment in one easy motion
3. Included IncreLok™ feature offers fixed tilt lock in 5° increments when used
4. Easy-Grip™ ratcheting handle locks tilt angle into place
5. Horizontal display adjustment up to 8" (203mm) for centering display on wall
6. Universal display adapters easily hook onto wall plate for fast installation
7. Fits displays with mounting hole patterns of 832 x 449mm (32.75"W x 17.67"H), including VESA® 800 x 400mm



Patented

For expanded product information and technical data visit [www.peerless-av.com](http://www.peerless-av.com)

## TECHNICAL DRAWINGS

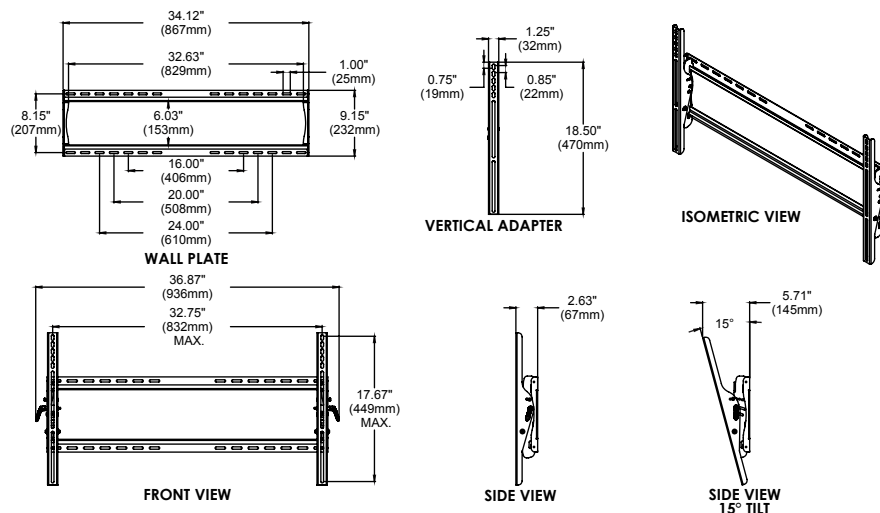

## MODELS

### Universal Models:

Includes theft resistant hardware for attaching display to mount

**ST660** Black  
**ST660-S** Silver

Includes standard hardware (hex or Phillips) for attaching display to mount

**ST660P** Black  
**ST660P-S** Silver

## DISPLAY ADAPTER



### Mounting Pattern

Universal Models: 832 x 449mm  
(32.75"W x 17.67"H)



### VESA® Pattern

Universal Models: Up to 800 x 400mm

## SPECIFICATIONS



### Distance from Wall

2.63"-5.71" (67-145mm)



### Tilt

+15/-5°



### Max Load

200 lb (90kg)

### Product Dimensions (W x H x D)

36.87" x 18.50" x 2.63"-5.71"  
(936 x 470 x 67-145mm)

### Mounting Surfaces

Wood stud, concrete, cinder block and metal stud  
(Metal stud accessory required)

### Ship Weight

11lb (5kg)

## CERTIFICATIONS



## ACCESSORIES



**ACC415:**  
4-pack Metal Stud  
Fastener Kit ..... pg# 196



**ACC309:**  
Video Conference Shelf ..... pg# 166



**IBA4-W:**  
Easy Mount Recessed  
Low Voltage Cable Plate ..... pg# 197

To verify mount compatibility with any flat panel display or projector model use MountFinder™ at [www.peerless-av.com](http://www.peerless-av.com)



CALL: 630-375-5100  
800-865-2112



FAX: 630-820-8537  
800-359-6500



E-MAIL:  
[info@peerless-av.com](mailto:info@peerless-av.com)



ONLINE:  
[www.peerless-av.com](http://www.peerless-av.com)



# SmartMount® Universal Tilt Wall Mount

For 42" to 71" Flat Panel Displays

## MODELS

### Universal Models:

Includes theft resistant hardware for attaching display to mount

**ST670** Black  
**ST670-S** Silver

Includes standard hardware (hex or Phillips) for attaching display to mount

**ST670P** Black  
**ST670P-S** Silver

## DISPLAY ADAPTER



### Mounting Pattern

Universal Models: 915 x 503mm  
(36.04"W x 19.80"H)

## SPECIFICATIONS



### Distance from Wall

3.04"-6.41" (77-163mm)



### Tilt

+15/-5°



### Max Load

250lb (113kg)

### Product Dimensions (W x H x D)

40.16" x 20.63" x 3.04"-6.41"  
(1020 x 524 x 77-163mm)

### Mounting Surfaces

Wood stud, concrete, cinder block and metal stud  
(Metal stud accessory required)

### Ship Weight

15.4lb (6.98kg)

1. Universal tilt adapters allow for +15/-5° tilt adjustment in one easy motion
2. Included IncreLok™ feature offers fixed tilt lock in 5° increments when used
3. Easy-Grip™ ratcheting handle locks tilt angle into place
4. Horizontal display adjustment up to 12" (304mm) for centering display on wall
5. Universal display adapters easily hook onto wall plate for fast installation
6. Fits displays with mounting hole patterns of 915 x 503mm (36.04"W x 19.80"H)
7. Wall plate knockouts provide wall access improving cable management options

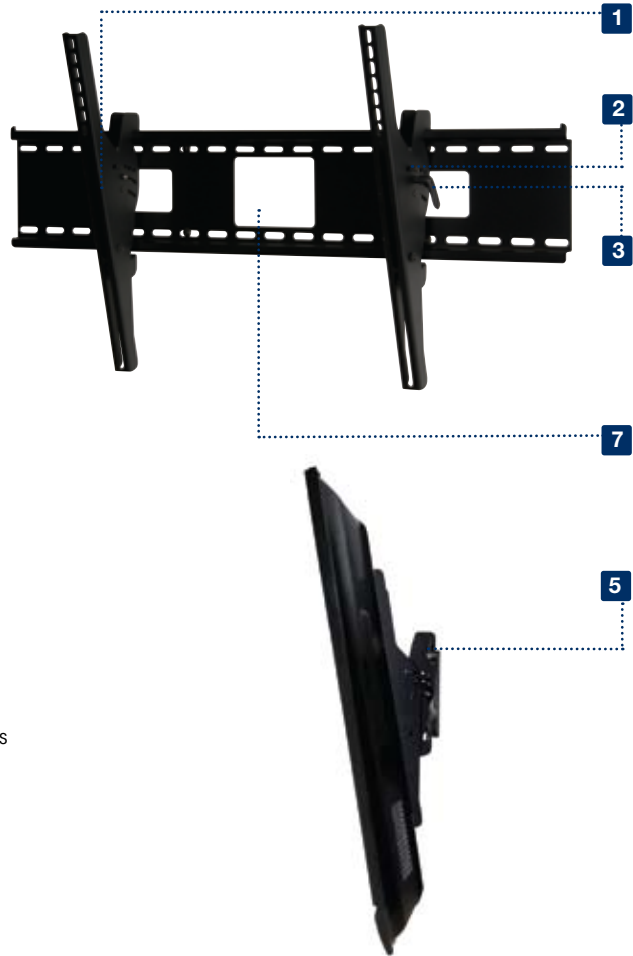

Patented

## CERTIFICATIONS



\* With max load up to 200lb (90kg)

## ACCESSORIES



**ACC615:**  
6-pack Metal Stud Fastener Kit ..... pg# 196



**ACC309:**  
Video Conference Shelf ..... pg# 166



**IBA4-W:**  
Easy Mount Recessed Low Voltage Cable Plate ..... pg# 197

## TECHNICAL DRAWINGS

For expanded product information and technical data visit [www.peerless-av.com](http://www.peerless-av.com)

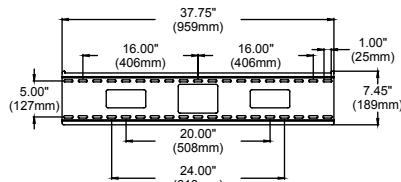

WALL PLATE

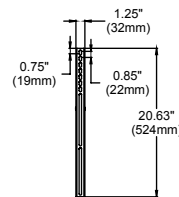

VERTICAL BRACKET

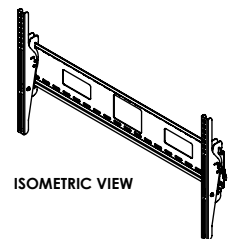

ISOMETRIC VIEW

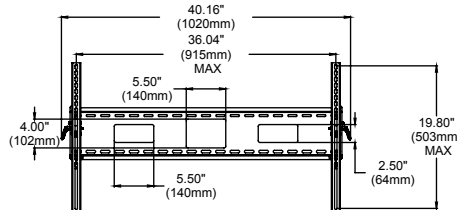

FRONT VIEW

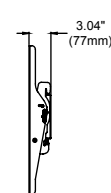

SIDE VIEW

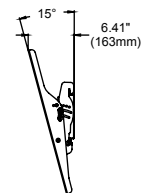

SIDE VIEW  
15° TILT

To verify mount compatibility with any flat panel display or projector model use MountFinder™ at [www.peerless-av.com](http://www.peerless-av.com)



CALL: 630-375-5100  
800-865-2112



FAX: 630-820-8537  
800-359-6500



E-MAIL: [info@peerless-av.com](mailto:info@peerless-av.com)



ONLINE: [www.peerless-av.com](http://www.peerless-av.com)

# SmartMount® Universal Tilt Wall Mount

For 61" to 102" Flat Panel Displays



FLAT PANEL MOUNTS

1. Universal tilt adapters allow for +15/-5° tilt adjustment in one easy motion
2. Included IncreLok™ feature offers fixed tilt lock in 5° increments when used
3. Easy-Grip™ ratcheting handle locks tilt angle into place
4. Horizontal display adjustment up to 12" (304mm) for centering display on wall
5. Universal display adapters easily hook onto wall plate for fast installation
6. Fits displays with mounting hole patterns of 1119 x 745mm (44.04"W x 29.31"H)
7. Wall plate knockouts provide wall access improving cable management options
8. Supports M10 mounting bolts

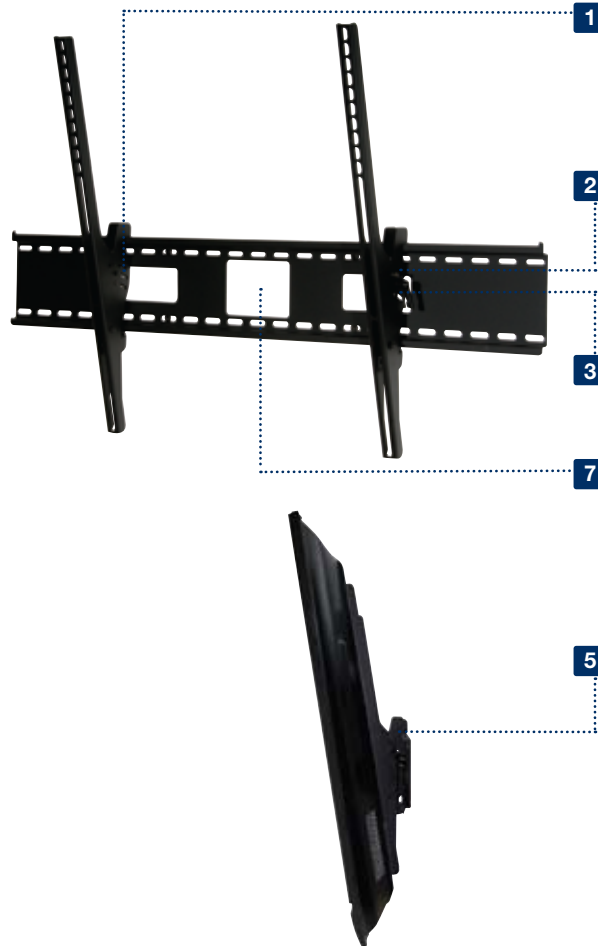

Patented

For expanded product information and technical data visit [www.peerless-av.com](http://www.peerless-av.com)

## TECHNICAL DRAWINGS

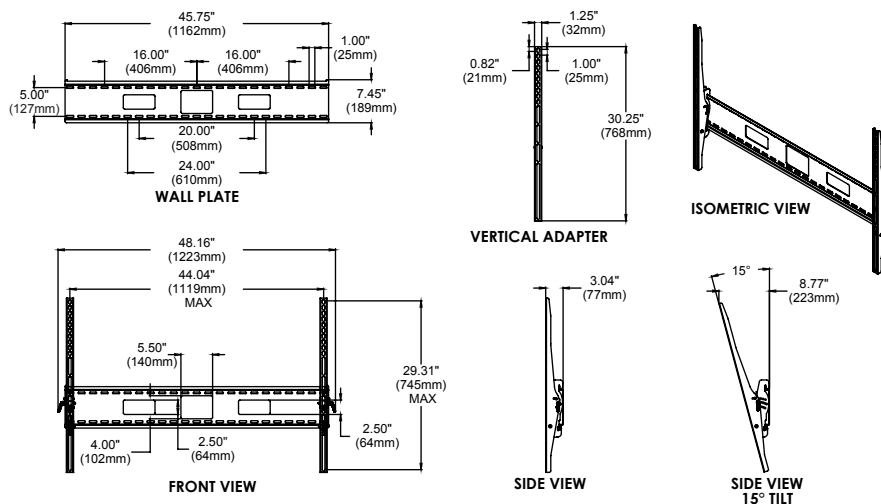

## MODELS

### Universal Models:

Includes theft resistant hardware for attaching display to mount

**ST680** Black  
**ST680-S** Silver

Includes standard hardware (hex or Phillips) for attaching display to mount

**ST680P** Black  
**ST680P-S** Silver

## DISPLAY ADAPTER



### Mounting Pattern

Universal Models: 1119 x 745mm  
(44.04"W x 29.31"H)

## SPECIFICATIONS



### Distance from Wall

3.04"-8.77" (77-223mm)



### Tilt

+15/-5°



### Max Load

350lb (158kg)

### Product Dimensions (W x H x D)

48.16" x 30.25" x 3.04"-8.77"  
(1223 x 768 x 77-223mm)

### Mounting Surfaces

Wood stud, concrete, cinder block and metal stud  
(Metal stud accessory required)

### Ship Weight

18.2lb (8.2kg)

## CERTIFICATIONS



\*With max load up to 200lb (90kg)

## ACCESSORIES



**ACC615:**  
6-pack Metal Stud Fastener Kit ..... pg# 196



**ACC309:**  
Video Conference Shelf ..... pg# 166



**IBA4-W:**  
Easy Mount Recessed Low Voltage Cable Plate ..... pg# 197

To verify mount compatibility with any flat panel display or projector model use MountFinder™ at [www.peerless-av.com](http://www.peerless-av.com)



CALL: 630-375-5100  
800-865-2112



FAX: 630-820-8537  
800-359-6500



E-MAIL:  
[info@peerless-av.com](mailto:info@peerless-av.com)



ONLINE:  
[www.peerless-av.com](http://www.peerless-av.com)



# SmartMount® Pivot Wall Mount

For 10" to 26" Flat Panel Displays

## MODELS

Includes standard hardware (hex or Phillips) for attaching display to mount

**Universal Models:** 10" to 24" displays

**SP730P** High gloss black  
**SP730P-S** High gloss silver

**Universal Models:** 10" to 26" displays

**SP735P** High gloss black  
**SP735P-S** High gloss silver

## DISPLAY ADAPTER



### Mounting Pattern

**Universal Models**  
**SP735P(-S):** 200 x 162mm  
(7.87"W x 6.39"H)



### VESA® Pattern

**Universal Models**  
**SP730P(-S):** 75 and 100mm  
**SP735P(-S):** Up to 200 x 100mm

## SPECIFICATIONS



### Distance from Wall

**SP730P(-S):** 2.19"-9.31" (56-237mm)  
**SP735P(-S):** 2.71"-10.16" (69-258mm)



### Tilt | Swivel | Roll

±35° | ±90° | ±7°



### Max Load

25lb (11kg)

### Product Dimensions (W x H x D)

**SP730P(-S):** 10.69" x 8.05" x 2.19"-9.31"  
(272 x 204 x 56-237mm)  
**SP735P(-S):** 13.19" x 8.05" x 2.71"-10.16"  
(335 x 204 x 69-258mm)

### Mounting Surfaces

Wood stud, concrete, cinder block and metal stud  
(Metal stud accessory required)

### Ship Weight

**SP730P(-S):** 2.76lb (1.2kg)  
**SP735P(-S):** 3.7lb (1.7kg)

## CERTIFICATIONS



## ACCESSORIES



**ACC918:** Security Fasteners ..... pg# 199



**WSP700/WSP701:** Metal Stud Wall Plates for 1 6/24" Center Metal Studs ... pg# 195



**IBA4-W:** Easy Mount Recessed Low Voltage Cable Plate ..... pg# 197



**IBA5-W:** Recessed Low Voltage Media Plate with Duplex Surge Suppressor .. pg# 197

1. Arm extends up to 9.31" (237mm) from wall with SP730P models and 10.16" (258mm) with SP735P(-S)
2. One-Touch™ tilt mechanism allows adjustment of ±35° without the use of tools
3. Up to 90° of side-to-side swivel
4. ±7° of roll for post installation display leveling
5. Integrated cable management keeps cables out of the way



**SP730P**  
Holds 10"-24" displays

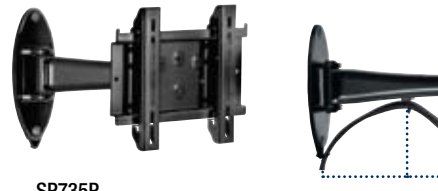

**SP735P**  
Holds 10"-26" displays

Patented

## TECHNICAL DRAWINGS

For expanded product information and technical data visit [www.peerless-av.com](http://www.peerless-av.com)

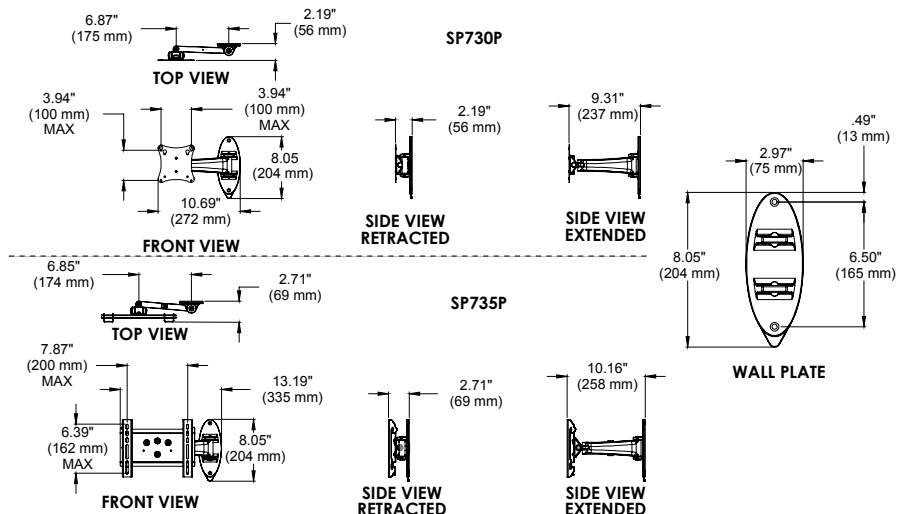

To verify mount compatibility with any flat panel display or projector model use MountFinder™ at [www.peerless-av.com](http://www.peerless-av.com)



**CALL:** 630-375-5100  
800-865-2112



**FAX:** 630-820-8537  
800-359-6500



**E-MAIL:**  
[info@peerless-av.com](mailto:info@peerless-av.com)



**ONLINE:**  
[www.peerless-av.com](http://www.peerless-av.com)



# SmartMount® Pivot Wall Mount

For 22" to 46" Flat Panel Displays



FLAT PANEL MOUNTS

1. Arm extends up to 11.8" (299mm) from wall with SP740P models and 12.55" (319mm) with SP746PU models
2. One-Touch™ tilt mechanism allows adjustment of +15/-5° without the use of tools
3. Up to ±90° of side-to-side swivel
4. ±5° of roll for post installation display leveling
5. Integrated cable management keeps cables out of the way
6. Compatible with flat panels that use M8 screws

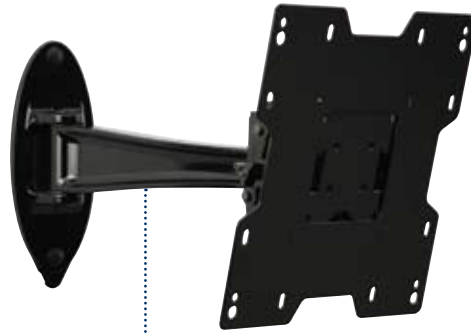

**SP740P**  
Holds 22"-40" displays



**SP746PU**  
Holds 26"-46" displays

Patented

For expanded product information and technical data visit [www.peerless-av.com](http://www.peerless-av.com)

## TECHNICAL DRAWINGS

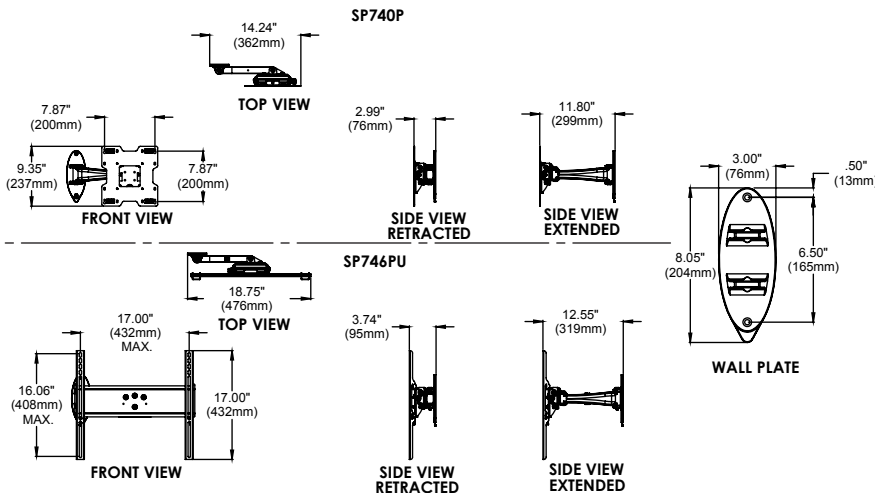

## MODELS

Includes standard hardware (hex or Phillips) for attaching display to mount

**Universal Models:** 22" to 40" displays

**SP740P** High gloss black  
**SP740P-S** High gloss silver

**Universal Models:** 26" to 46" displays

**SP746PU** High gloss black

## DISPLAY ADAPTER



### Mounting Pattern

**Universal Models**

**SP746PU:** 432 x 408mm  
(17"W x 16.06"H)



### VESA® Pattern

**Universal Models**

**SP740P(-S):** 75, 100, 200 x 100 and 200 x 200mm  
**SP746PU:** Up to 400 x 400mm

## SPECIFICATIONS



### Distance from Wall

**SP740P(-S):** 2.99"-11.80" (76-299mm)  
**SP746PU:** 3.74"-12.55" (95-319mm)



### Tilt | Swivel | Roll

+15/-5° | ±90° | ±5°



### Max Load

80lb (36kg)

### Product Dimensions (W x H x D)

**SP740P(-S):** 14.24" x 9.35" x 2.99"-11.80"  
(362-349 x 237 x 76-299mm)

**SP746PU:** 18.75" x 17.00" x 3.74"-12.55"  
(476 x 432 x 95-319mm)

### Mounting Surfaces

Wood stud, concrete, cinder block and metal stud  
(Metal stud accessory required)

### Ship Weight

**SP740P(-S):** 6.7lb (3kg)  
**SP746PU:** 7.7lb (3.5kg)

## CERTIFICATIONS



OSHPD Approval Pending

## ACCESSORIES



**ACC919:**  
Security Fasteners ..... pg# 199



**WSP700/WSP701:**  
Metal Stud Wall Plates for 16"/24" Center Metal Studs .. pg# 195



**IBA4-W:**  
Easy Mount Recessed Low Voltage Cable Plate ..... pg# 197



**IBA5-W:**  
Recessed Low Voltage Media Plate with Duplex Surge Suppressor .. pg# 197

To verify mount compatibility with any flat panel display or projector model use MountFinder™ at [www.peerless-av.com](http://www.peerless-av.com)



**CALL:** 630-375-5100  
800-865-2112



**FAX:** 630-820-8537  
800-359-6500



**E-MAIL:**  
[info@peerless-av.com](mailto:info@peerless-av.com)



**ONLINE:**  
[www.peerless-av.com](http://www.peerless-av.com)

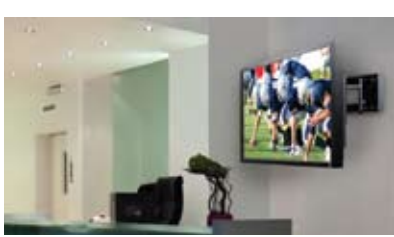

# SmartMount® Pull-Out Pivot Wall Mount

For 26" to 65" Flat Panel Displays

## MODELS

**Universal Models:** 32" to 65" displays

Includes theft resistant hardware for attaching display to mount

**SP850-UNL** Black  
**SP850-UNL-S** Silver

Includes standard hardware (hex or Phillips) for attaching display to mount

**SP850-UNLP** Black  
**SP850-UNLP-S** Silver

**SP850-UNLP-GB** High gloss black  
**SP850-UNLP-GS** High gloss silver

**Dedicated Models:** 26" to 58" displays

Display adapter purchased separately for non-VESA® displays\*  
Includes theft resistant hardware for attaching display to mount

**SP850** Black  
**SP850-S** Silver

Includes standard hardware (hex or Phillips) for attaching display to mount

**SP850P** Black  
**SP850P-S** Silver

\*Dedicated adapter plates come in flat black and include security fasteners

## DISPLAY ADAPTER



### Mounting Pattern

**Universal Models:** 729 x 433mm  
(28.7"W x 17.05"H)



### VESA® Pattern

**Dedicated Models:** 100 and 200 x 100mm  
Non-VESA® compliant displays require display-specific adapter to be purchased separately.

## SPECIFICATIONS



### Distance from Wall

**Universal Models:** 3.40"-11.90" (86-302mm)  
**Dedicated Models:** 2.31"-10.68" (59-271mm)  
(See drawing)



### Tilt | Swivel | Roll

0°, 5° or 10° | ±45° | ±1°



### Max Load

150lb (68kg)

### Product Dimensions (W x H x D)

**Universal Models:** 30.75" x 18.00" x 3.40"-11.90"  
(781 x 457 x 86-302mm)  
**Dedicated Models:** 21.00" x 9.76" x 2.31"-10.68"  
(533 x 248 x 59-271mm)

### Mounting Surfaces

Wood stud, concrete and cinder block

### Ship Weight

**Universal Models:** 39lb (17.6kg)  
**Dedicated Models:** 22.7lb (10.24kg)

## CERTIFICATIONS



OSHPD Approval Pending

SP850(P)(-S)

## ACCESSORIES



**WSP816/WSP820/WSP824:**  
Metal Stud Wall Plates ..... pg# 196

### Universal Models



- Arms extend up to 10.68" (271mm) from wall (plus thickness of adapter plate)
- Pull-out pivot with up to 90° rotation
- Included IncreLok™ feature offers 0°, 5° or 10° lockable tilt when used
- Built-in cable management
- ±1° of roll for post installation display leveling
- Locking tab included for optional pivot restriction to one side
- Dedicated models include VESA® 100 and 200 x 100mm compliant adapter plate
- Lock Key™ installation tool secures arms for display installation

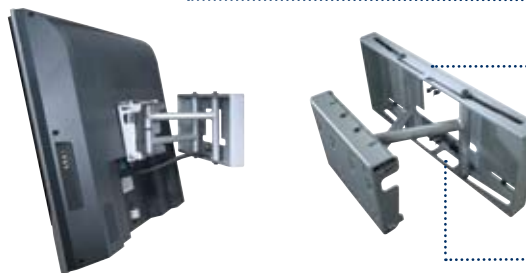

### Dedicated Models

Patented

## TECHNICAL DRAWINGS

For expanded product information and technical data visit [www.peerless-av.com](http://www.peerless-av.com)

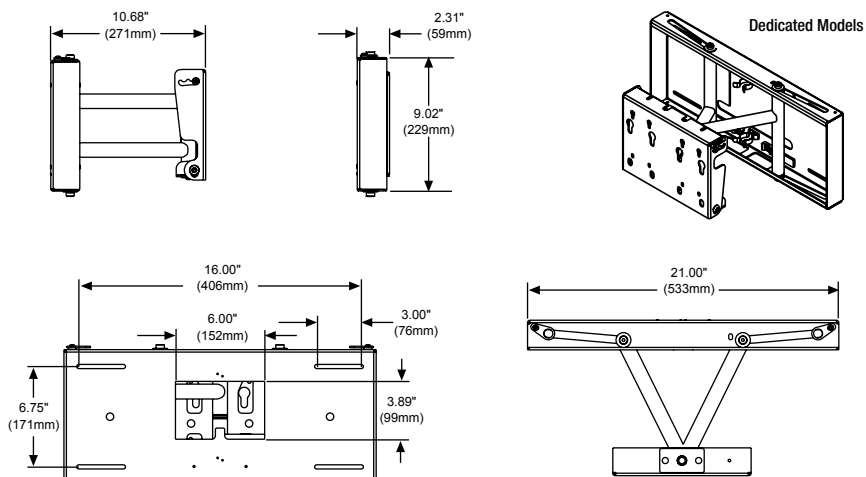

To verify mount compatibility with any flat panel display or projector model use MountFinder™ at [www.peerless-av.com](http://www.peerless-av.com)



CALL: 630-375-5100  
800-865-2112



FAX: 630-820-8537  
800-359-6500



E-MAIL: [info@peerless-av.com](mailto:info@peerless-av.com)



ONLINE: [www.peerless-av.com](http://www.peerless-av.com)

# SmartMount® Articulating Wall Arm

## For 10" to 24" Flat Panel Displays



FLAT PANEL MOUNTS

1. VESA® 75 and 100mm compliant
2. Arm extends up to 16.06" (408mm) from wall
3. Three adjustable pivot points for versatile display positioning
4. One-Touch™ tilt mechanism allows adjustment of ±35° without the use of tools
5. ±7° of roll for post installation display leveling
6. Up to ±90° of side-to-side swivel
7. Integrated cable management system keep cables out of the way
8. Display is centered on wall plate
9. Non-VESA® adapter plates also available



Patented

For expanded product information and technical data visit [www.peerless-av.com](http://www.peerless-av.com)

### TECHNICAL DRAWINGS

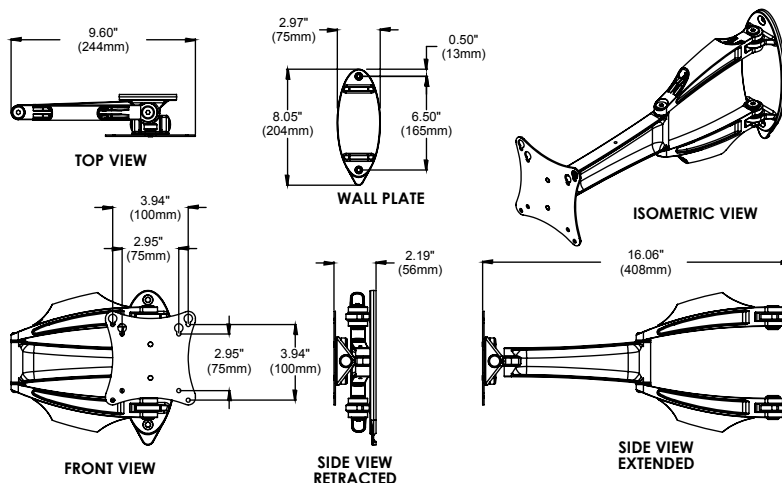

### MODELS

#### Universal Models:

Includes standard hardware (hex or Phillips) for attaching display to mount

**SA730P** High gloss black  
**SA730P-S** High gloss silver

### DISPLAY ADAPTER



#### VESA® Pattern

Universal Models: 75 and 100mm

### SPECIFICATIONS



#### Distance from Wall

2.19"-16.06" (56-408mm)



#### Tilt | Swivel | Roll

±35° | ±90° | ±7°



#### Max Load

25lb (11kg)

#### Product Dimensions (W x H x D)

9.60" x 8.05" x 2.19"-16.06"  
(244 x 204 x 56-408mm)

#### Mounting Surfaces

Wood stud, concrete, cinder block and metal stud  
(Metal stud accessory required)

#### Ship Weight

3.5lb (1.5kg)

### CERTIFICATIONS



### ACCESSORIES



**ACC918:** Security Fasteners ..... pg# 199



**WSP700/WSP701:** Metal Stud Wall Plates for 16"/24" Center Metal Studs .. pg# 195



**IBA4-W:** Easy Mount Recessed Low Voltage Cable Plate ..... pg# 197



**IBA5-W:** Recessed Low Voltage Media Plate with Duplex Surge Suppressor .. pg# 197

To verify mount compatibility with any flat panel display or projector model use MountFinder™ at [www.peerless-av.com](http://www.peerless-av.com)



CALL: 630-375-5100  
800-865-2112



FAX: 630-820-8537  
800-359-6500



E-MAIL: [info@peerless-av.com](mailto:info@peerless-av.com)



ONLINE: [www.peerless-av.com](http://www.peerless-av.com)

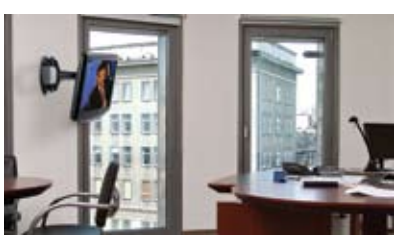

# SmartMount® Articulating Wall Arm

For 10" to 26" Flat Panel Displays

## MODELS

### Universal Models:

Includes standard hardware (hex or Phillips) for attaching display to mount

- SA735P** High gloss black
- SA735P-S** High gloss silver

## DISPLAY ADAPTER

### Mounting Pattern

Universal Models: 7.93"W x 6.26"H  
(201 x 159mm)

### VESA® Pattern

Universal Models: Up to 200 x 100mm

## SPECIFICATIONS

### Distance from Wall

3.03"-16.90" (77-429mm)

### Tilt | Swivel | Roll

±35° | ±90° | ±7°

### Max Load

25lb (11kg)

### Product Dimensions (W x H x D)

12.08" x 8.05" x 3.03"-16.90"  
(307 x 204 x 77-429mm)

### Mounting Surfaces

Wood stud, concrete, cinder block and metal stud  
(Metal stud accessory required)

### Ship Weight

4.2lb (1.9kg)

1. Universal display adapters provide compatibility with displays with up to a VESA® 200 x 100mm mounting hole pattern
2. Arm extends up to 16.90" (429mm) from wall
3. Three adjustable pivot points for versatile display positioning
4. One-Touch™ tilt mechanism allows adjustment of ±35° without the use of tools
5. ±7° of roll for post installation display leveling
6. Integrated cable management keeps cables out of the way
7. Display is centered on wall plate

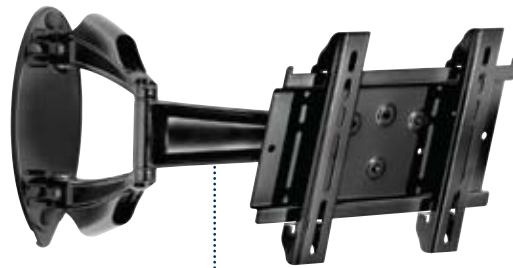

Patented

## CERTIFICATIONS



## ACCESSORIES



**ACC919:** Security Fasteners ..... pg# 199



**WSP700/WSP701:** Metal Stud Wall Plates for 16"/24" Center Metal Studs .. pg# 195



**IBA4-W:** Easy Mount Recessed Low Voltage Cable Plate ..... pg# 197



**IBA5-W:** Recessed Low Voltage Media Plate with Duplex Surge Suppressor .. pg# 197

## TECHNICAL DRAWINGS

For expanded product information and technical data visit [www.peerless-av.com](http://www.peerless-av.com)

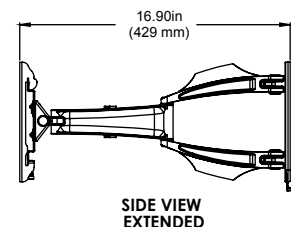
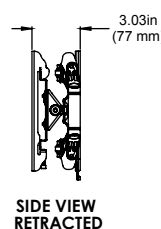
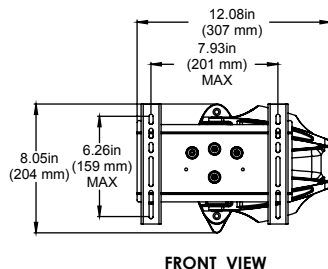
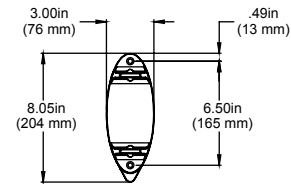
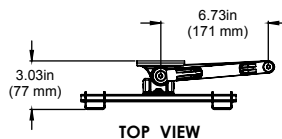

To verify mount compatibility with any flat panel display or projector model use MountFinder™ at [www.peerless-av.com](http://www.peerless-av.com)



CALL: 630-375-5100  
800-865-2112



FAX: 630-820-8537  
800-359-6500



E-MAIL: [info@peerless-av.com](mailto:info@peerless-av.com)



ONLINE: [www.peerless-av.com](http://www.peerless-av.com)

# SmartMount® Articulating Wall Arm

For 22" to 40" Flat Panel Displays

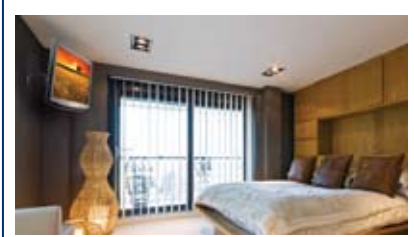

FLAT PANEL MOUNTS

1. VESA® 75, 100, 200 x 100 and 200 x 200mm compliant
2. Arm extends up to 20.18" (513mm) from wall
3. Three adjustable pivot points for versatile display positioning
4. One-Touch™ tilt mechanism allows adjustment of +15/-5° without the use of tools
5. Up to ±90° of side-to-side swivel
6. ±5° of roll for post installation display leveling
7. Integrated cable management keeps cables out of the way
8. Display is centered on wall plate
9. Non-VESA® adapter plates also available
10. Compatible with flat panels that use M8 screws

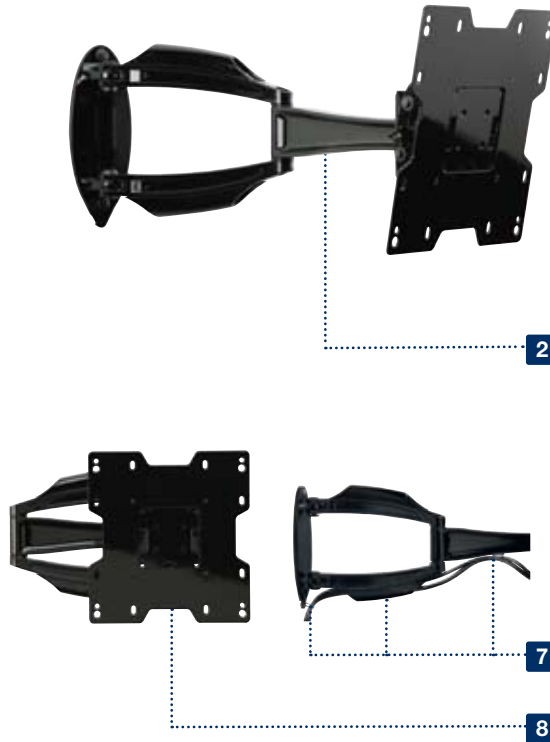

Patented

For expanded product information and technical data visit [www.peerless-av.com](http://www.peerless-av.com)

## TECHNICAL DRAWINGS

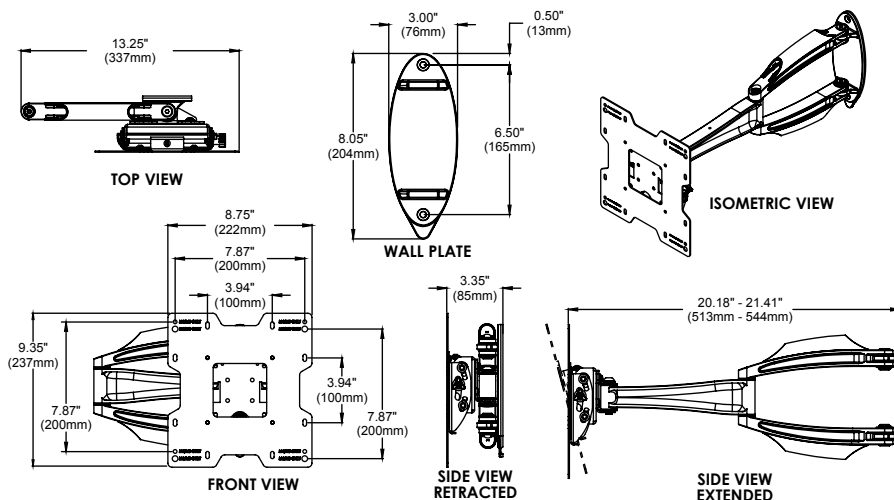

## MODELS

### Universal Models:

Includes standard hardware (hex or Phillips) for attaching display to mount

**SA740P** High gloss black  
**SA740P-S** High gloss silver

## DISPLAY ADAPTER



### VESA® Pattern

Universal Models: 75, 100, 200 x 100 and 200 x 200mm

## SPECIFICATIONS



### Distance from Wall

3.35"-20.18" (85-513mm)



### Tilt | Swivel | Roll

+15/-5° | ±90° | ±5°



### Max Load

80lb (36kg)

### Product Dimensions (W x H x D)

13.25" x 9.35" x 3.35"-20.18"  
 (337 x 237 x 85-513mm)

### Mounting Surfaces

Wood stud, concrete, cinder block and metal stud  
 (Metal stud accessory required)

### Ship Weight

8.45lb (3.8kg)

## CERTIFICATIONS



## ACCESSORIES



**ACC919:** Security Fasteners ..... pg# 199



**WSP700/WSP701:** Metal Stud Wall Plates for 16"/24" Center Metal Studs .. pg# 195



**IBA4-W:** Easy Mount Recessed Low Voltage Cable Plate ..... pg# 197

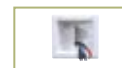

**IBA5-W:** Recessed Low Voltage Media Plate with Duplex Surge Suppressor .. pg# 197

To verify mount compatibility with any flat panel display or projector model use MountFinder™ at [www.peerless-av.com](http://www.peerless-av.com)



CALL: 630-375-5100  
800-865-2112



FAX: 630-820-8537  
800-359-6500



E-MAIL: [info@peerless-av.com](mailto:info@peerless-av.com)



ONLINE: [www.peerless-av.com](http://www.peerless-av.com)





# SmartMount® Articulating Wall Arm

For 26" to 46" Flat Panel Displays

## MODELS

### Universal Models:

Includes standard hardware (hex or Phillips) for attaching display to mount

**SA746PU** High gloss black

## DISPLAY ADAPTER

### Mounting Pattern

Universal Models: 432 x 408mm  
(17"W x 16.06"H)

### VESA® Pattern

Universal Models: Up to 400 x 400mm

## SPECIFICATIONS

### Distance from Wall

4.34"-20.92" (110-531mm)

### Tilt | Swivel | Roll

+15°/-5° | ±90° | ±5°

### Max Load

80lb (36kg)

### Product Dimensions (W x H x D)

18.75" x 17.00" x 4.34"-20.92"  
(476 x 432 x 110-531mm)

### Mounting Surfaces

Wood stud, concrete, cinder block and metal stud  
(Metal stud accessory required)

### Ship Weight

9.5lb (4.3kg)

1. Universal display adapters provide compatibility with displays with up to a VESA® 400 x 400mm mounting hole pattern
2. Arm extends up to 20.92" (531mm) from wall
3. Three adjustable pivot points for versatile display positioning
4. One-Touch™ tilt mechanism allows adjustment of +15°/-5° without the use of tools
5. ±5° of roll for post installation display leveling
6. Integrated cable management keeps cables out of the way
7. Display is centered on wall plate



Patented

## CERTIFICATIONS



## ACCESSORIES



**ACC919:** Security Fasteners ..... pg# 199



**WSP700/WSP701:** Metal Stud Wall Plates for 16"/24" Center Metal Studs .. pg# 195



**IBA4-W:** Easy Mount Recessed Low Voltage Cable Plate ..... pg# 197



**IBA5-W:** Recessed Low Voltage Media Plate with Duplex Surge Suppressor .. pg# 197

## TECHNICAL DRAWINGS

For expanded product information and technical data visit [www.peerless-av.com](http://www.peerless-av.com)

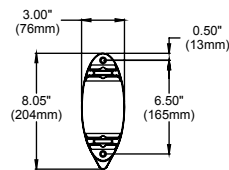

WALL PLATE

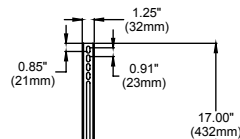

VERTICAL ADAPTER

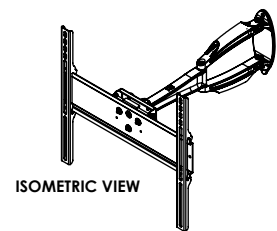

ISOMETRIC VIEW

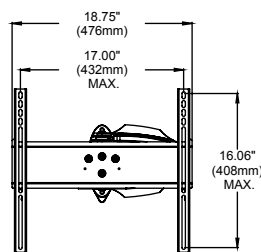

FRONT VIEW

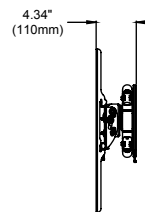

SIDE VIEW

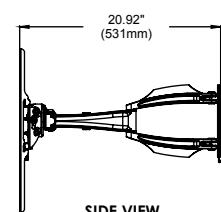

SIDE VIEW EXTENDED

To verify mount compatibility with any flat panel display or projector model use MountFinder™ at [www.peerless-av.com](http://www.peerless-av.com)



CALL: 630-375-5100  
800-865-2112



FAX: 630-820-8537  
800-359-6500



E-MAIL: [info@peerless-av.com](mailto:info@peerless-av.com)



ONLINE: [www.peerless-av.com](http://www.peerless-av.com)

# SmartMount® Articulating Wall Arm

## For 32" to 52" Flat Panel Displays

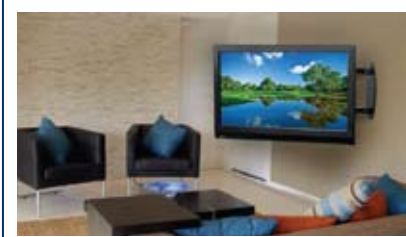

FLAT PANEL MOUNTS

1. Arm extends up to 27.43" (697mm) from wall (including thickness of display adapter)
2. Integrated cable management provides ample area to run cables to complete a professional and discrete installation
3. One-Touch™ tilt mechanism allows adjustment of +15°/-5° without the use of tools
4. ±5° of roll for post installation display leveling
5. Display can be rotated from portrait to landscape without removing the display
6. ±0.5" (13mm) vertical adjustment for fine tuning display position

Universal Models



Patented

For expanded product information and technical data visit [www.peerless-av.com](http://www.peerless-av.com)

### TECHNICAL DRAWINGS

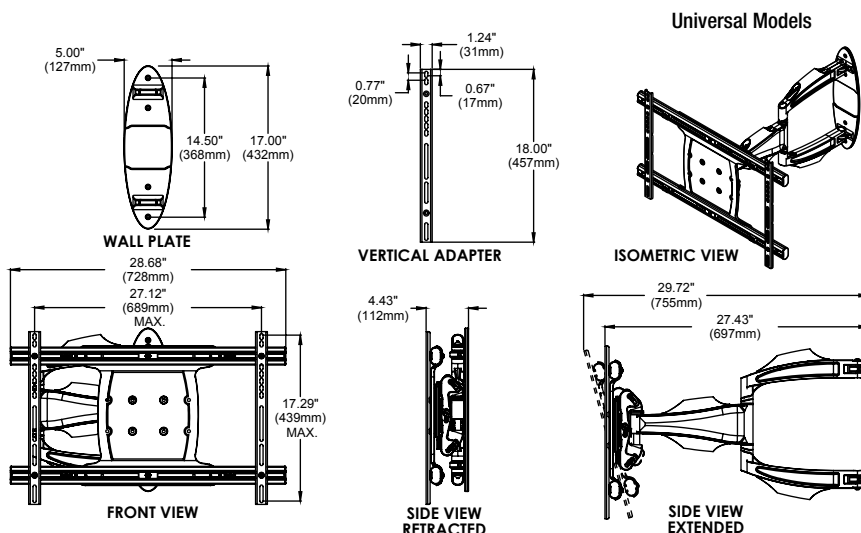

### MODELS

#### Universal Models:

Includes standard hardware (hex or Phillips) for attaching display to mount  
**SA752PU** High gloss black

#### Dedicated Models:

Includes standard hardware (hex or Phillips) for attaching display to mount  
 Requires Display Adapter to be Purchased Separately\*  
**SA752P** High gloss black

\*Dedicated adapter plates come in flat black and include security fasteners

### DISPLAY ADAPTER



#### Mounting Pattern

Universal Models: 689 x 439mm  
 (27.12"W x 17.29"H)



#### VESA® Pattern

Universal Models: Up to 600 x 400mm

Dedicated Models: Requires display-specific PLP or LC adapter to be purchased separately.

### SPECIFICATIONS



#### Distance from Wall

Universal Models: 4.43"-27.43" (113-697mm)  
 Dedicated Models: 2.73"-25.73" (69-654mm)



#### Tilt | Swivel | Roll

+15/-5° | ±90° | ±5°



#### Max Load

90lb (41kg)



#### Landscape to Portrait

Display can be rotated from landscape to portrait without removing the display

#### Product Dimensions (W x H x D)

Universal Models: 28.68" x 18.00" x 4.43"-27.43"  
 (728 x 457 x 113-697mm)  
 Dedicated Models: 15.2" x 17.00" x 2.73"-25.73"  
 (386 x 431 x 69-654mm)

#### Mounting Surfaces

Wood stud, concrete, cinder block and metal stud  
 (Metal stud accessory required)

#### Ship Weight

Universal Models: 38lb (17.3kg)  
 Dedicated Models: 22lb (10kg)

### CERTIFICATIONS



OSHPD Approval Pending

### ACCESSORIES



**ACC925:** Security Fasteners ..... pg# 199



**WSP756:** Metal Stud Wall Plate ..... pg# 195



**IBA4-W:** Easy Mount Recessed Low Voltage Cable Plate ..... pg# 197

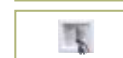

**IBA5-W:** Recessed Low Voltage Media Plate with Duplex Surge Suppressor .. pg# 197

To verify mount compatibility with any flat panel display or projector model use MountFinder™ at [www.peerless-av.com](http://www.peerless-av.com)



CALL: 630-375-5100  
 800-865-2112



FAX: 630-820-8537  
 800-359-6500



E-MAIL: [info@peerless-av.com](mailto:info@peerless-av.com)



ONLINE: [www.peerless-av.com](http://www.peerless-av.com)



# SmartMount® Articulating Wall Arm

For 37" to 60" Flat Panel Displays

## MODELS

### Universal Models:

Includes standard hardware (hex or Phillips) for attaching display to mount  
**SA761P** High gloss black

### Dedicated Models:

Includes standard hardware (hex or Phillips) for attaching display to mount  
 Requires Display Adapter to be Purchased Separately  
**SA761P** High gloss black

\* Dedicated adapter plates come in flat black and include security fasteners

## DISPLAY ADAPTER



### Mounting Pattern

**Universal Models:** 689 x 439mm  
 (27.12"W x 17.29"H)



### VESA® Pattern

**Universal Models:** Up to 600 x 400mm

**Dedicated Models:** Requires display-specific PLP or LC adapter to be purchased separately.

## SPECIFICATIONS



### Distance from Wall

**Universal Models:** 4.43"-27.55" (113-700mm)  
**Dedicated Models:** 2.85"-25.85" (72-657mm)



### Tilt | Swivel | Roll

+15/-5° | ±90° | ±5°



### Max Load

130lb (59kg)



### Landscape to Portrait

Display can be rotated from landscape to portrait without removing the display

### Product Dimensions (W x H x D)

**Universal Models:** 28.68" x 20.23" x 4.43"-27.55"  
 (728 x 514 x 113-700mm)

**Dedicated Models:** 19.5" x 20.23" x 2.83"-25.83"  
 (495 x 514 x 72-656mm)

### Mounting Surfaces

Wood stud, concrete, cinder block and metal stud  
 (Metal stud accessory required)

### Ship Weight

**Universal Models:** 45lb (21kg)

**Dedicated Models:** 33lb (15kg)

## CERTIFICATIONS

UL US RoHS 2002/95/EC MADE IN USA OSHPD Approval Pending

## ACCESSORIES



**ACC925:** Security Fasteners ..... pg# 199



**WSP756:** Metal Stud Wall Plate..... pg# 195



**IBA4-W:** Easy Mount Recessed Low Voltage Cable Plate ..... pg# 197



**IBA5-W:** Recessed Low Voltage Media Plate with Duplex Surge Suppressor .. pg# 197

1. Arm extends up to 27.55" (700mm) from wall (including thickness of display adapter)
2. Integrated cable management provides ample area to run cables to complete a professional and discrete installation
3. One-Touch™ tilt mechanism allows adjustment of +15°/-5° without the use of tools
4. ±5° of roll for post installation display leveling
5. Display can be rotated from portrait to landscape without removing the display
6. Minimalistic wall plate footprint for increased wall access and improved aesthetic
7. Horizontal adjustment up to 4.5" (114mm) for perfect display placement
8. ±0.5" (13mm) vertical adjustment for fine tuning display position
9. Display is centered on wall plate

Universal Models

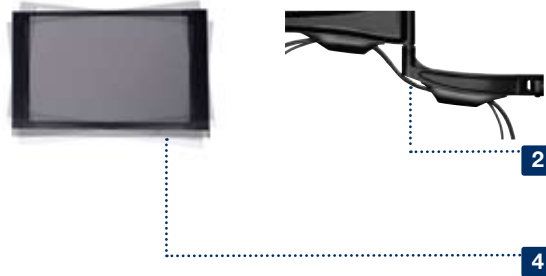
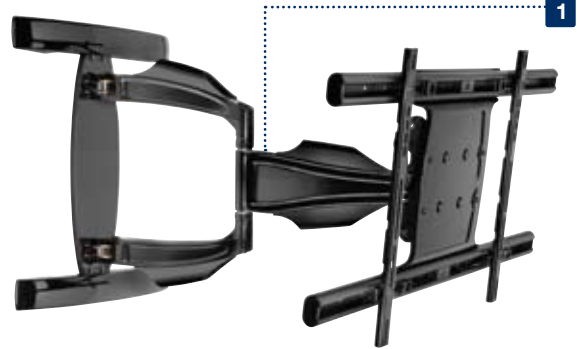

Patented

## TECHNICAL DRAWINGS

For expanded product information and technical data visit [www.peerless-av.com](http://www.peerless-av.com)

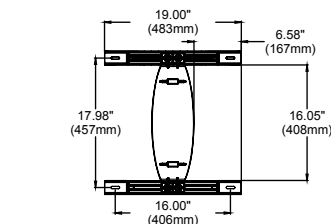

WALL PLATE

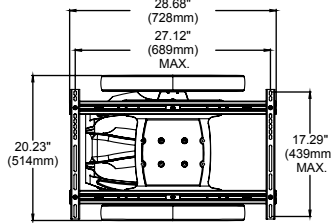

FRONT VIEW

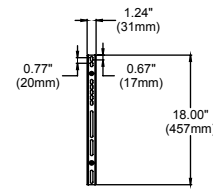

VERTICAL ADAPTER

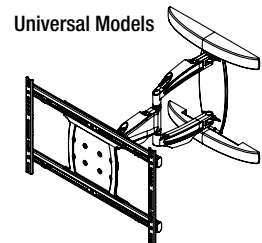

ISOMETRIC VIEW

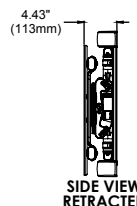

SIDE VIEW RETRACTED

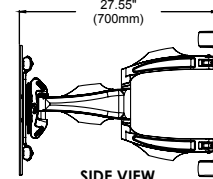

SIDE VIEW EXTENDED



# SmartMount® Articulating Wall Arm

For 37" to 63" Flat Panel Displays



FLAT PANEL MOUNTS

1. Dual arm construction for added strength and smooth motion on larger displays
2. Arms extends up to 27.55" (700mm) from wall (including thickness of display adapter)
3. Minimalistic wall plate footprint for increased wall access and improved aesthetic
4. Horizontal adjustment up to 4.5" (114mm) for perfect display placement
5. Integrated cable management provides ample area to run cables to complete a professional and discrete installation
6. One-Touch™ tilt mechanism allows adjustment of +15°/-5° without the use of tools
7. ±5° of roll for post installation display leveling
8. Display can be rotated from portrait to landscape without removing the display
9. ±0.5" (13mm) vertical adjustment for fine tuning display position
10. Display is centered on wall plate

## Universal Models

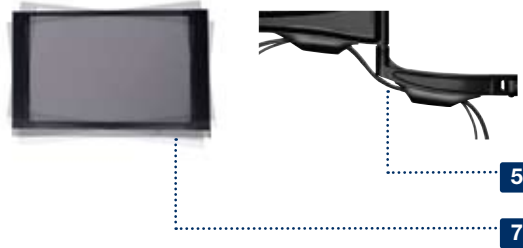
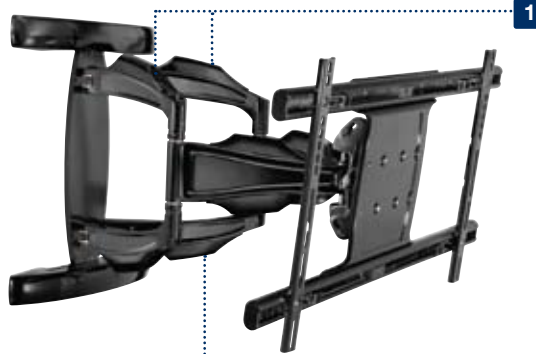

Patented

For expanded product information and technical data visit [www.peerless-av.com](http://www.peerless-av.com)

## TECHNICAL DRAWINGS

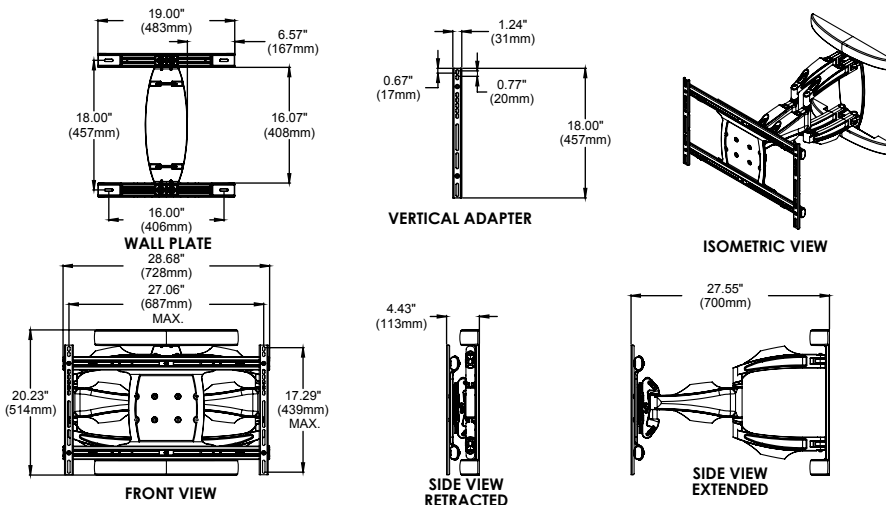

## MODELS

### Universal Models:

Includes standard hardware (hex or Phillips) for attaching display to mount  
**SA763PU** High gloss black

## DISPLAY ADAPTER



### Mounting Pattern

Universal Models: 687 x 439mm  
(27.06"W x 17.29"H)



### VESA® Pattern

Universal Models: Up to 600 x 400mm

## SPECIFICATIONS



### Distance from Wall

Universal Models: 4.43"-27.55" (113-700mm)



### Tilt | Swivel | Roll

+15/-5° | ±90° | ±5°



### Max Load

200lb (91kg)



### Landscape to Portrait

Display can be rotated from landscape to portrait without removing the display

### Product Dimensions (W x H x D)

Universal Models: 28.68" x 20.23" x 4.43"-27.55"  
(728 x 514 x 113-700mm)

### Mounting Surfaces

Wood stud, concrete, cinder block and metal stud  
(Metal stud accessory required)

### Ship Weight

Universal Models: 55lb (25kg)

## CERTIFICATIONS



OSHPD Approval Pending

## ACCESSORIES



**ACC925:** Security Fasteners ..... pg# 199



**WSP756:** Metal Stud Wall Plate..... pg# 195



**IBA4-W:** Easy Mount Recessed Low Voltage Cable Plate ..... pg# 197

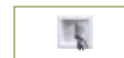

**IBA5-W:** Recessed Low Voltage Media Plate with Duplex Surge Suppressor .. pg# 197

To verify mount compatibility with any flat panel display or projector model use MountFinder™ at [www.peerless-av.com](http://www.peerless-av.com)



CALL: 630-375-5100  
800-865-2112



FAX: 630-820-8537  
800-359-6500



E-MAIL: [info@peerless-av.com](mailto:info@peerless-av.com)



ONLINE: [www.peerless-av.com](http://www.peerless-av.com)

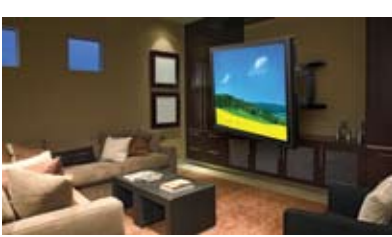

# SmartMount® Articulating Wall Arm

For 37" to 71" Flat Panel Displays

## MODELS

### Universal Models:

Includes standard hardware (hex or Phillips) for attaching display to mount  
**SA771PU** High gloss black

### Dedicated Models:

Includes standard hardware (hex or Phillips) for attaching display to mount  
 Requires Display Adapter to be Purchased Separately  
**SA771P** High gloss black

\* Dedicated adapter plates come in flat black and include security fasteners

## DISPLAY ADAPTER



### Mounting Pattern

**Universal Models:** 827 x 439mm  
 (32.56"W x 17.29"H)



### VESA® Pattern

**Universal Models:** Up to 800 x 400mm

**Dedicated Models:** Requires display-specific PLP or LC adapter to be purchased separately.

## SPECIFICATIONS



### Distance from Wall

**Universal Models:** 4.43"-27.55" (113-700mm)  
**Dedicated Models:** 2.83"-25.83" (72-656mm)



### Tilt | Swivel | Roll

+15°/-5° | ±90° | ±5°



### Max Load

200lb (91kg)



### Landscape to Portrait

Display can be rotated from landscape to portrait without removing the display

### Product Dimensions (W x H x D)

**Universal Models:** 34.38" x 20.23" x 4.43"-27.55"  
 (873 x 514 x 113-700mm)

**Dedicated Models:** 19.20" x 20.23" x 2.83"-25.83"  
 (488 x 514 x 72-656mm)

### Mounting Surfaces

Wood stud, concrete, cinder block and metal stud  
 (Metal stud accessory required)

### Ship Weight

**Universal Models:** 72lb (33kg)

**Dedicated Models:** 43lb (20kg)

## CERTIFICATIONS

UL US RoHS MADE IN USA OSHPD Approval Pending

## ACCESSORIES



**ACC925:** Security Fasteners ..... pg# 199



**WSP756:** Metal Stud Wall Plate..... pg# 195



**IBA4-W:** Easy Mount Recessed Low Voltage Cable Plate ..... pg# 197



**IBA5-W:** Recessed Low Voltage Media Plate with Duplex Surge Suppressor ... pg# 197

1. Dual arm construction for added strength and smooth motion on larger displays
2. Arms extends up to 27.55" (700mm) from wall (including thickness of display adapter)
3. Minimalistic wall plate footprint for increased wall access and improved aesthetic
4. Horizontal adjustment up to 4.5" (114mm) for perfect display placement
5. Integrated cable management provides ample area to run cables to complete a professional and discrete installation
6. One-Touch™ tilt mechanism allows adjustment of +15°/-5° without the use of tools
7. ±5° of roll for post installation display leveling
8. Display can be rotated from portrait to landscape without removing the display
9. ±0.5" (13mm) vertical adjustment for fine tuning display position

### Universal Models



Patented

## TECHNICAL DRAWINGS

For expanded product information and technical data visit [www.peerless-av.com](http://www.peerless-av.com)

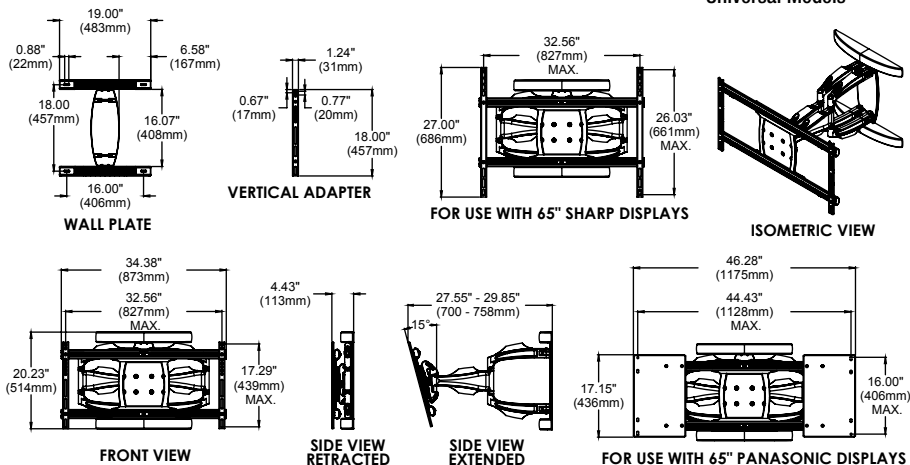

To verify mount compatibility with any flat panel display or projector model use MountFinder™ at [www.peerless-av.com](http://www.peerless-av.com)



CALL: 630-375-5100  
 800-865-2112



FAX: 630-820-8537  
 800-359-6500



E-MAIL: [info@peerless-av.com](mailto:info@peerless-av.com)



ONLINE: [www.peerless-av.com](http://www.peerless-av.com)



# Display-Specific Flat Wall Mount

For up to 71" Flat Panel Displays

1. Measures 1.18" (30mm) from wall, plus thickness of adapter plate
2. Horizontal display adjustment up to 8" (203mm) for centering display on wall
3. Easy-Glide™ design ensures display is securely attached to wall plate
4. Choose from 16" (406mm) only or 16"-24" (406-610mm) stud center wall plate
5. Fits any display-specific PLP or LC adapter plate
6. Model SF16D ships with 19.25" (489mm) wide wall plate, perfect for portrait style installations
7. Wall plate knockouts provide wall access, improving cable management options



SF24D



SF16D

For expanded product information and technical data visit [www.peerless-av.com](http://www.peerless-av.com)

## TECHNICAL DRAWINGS

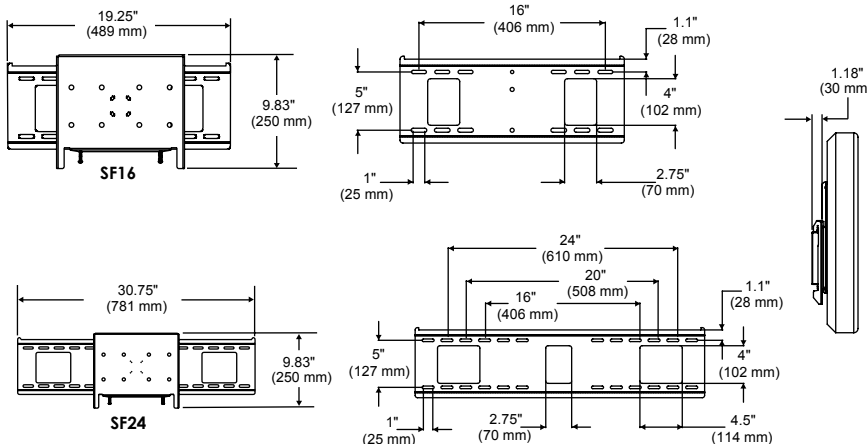

To verify mount compatibility with any flat panel display or projector model use MountFinder™ at [www.peerless-av.com](http://www.peerless-av.com)



CALL: 630-375-5100  
800-865-2112



FAX: 630-820-8537  
800-359-6500



E-MAIL: [info@peerless-av.com](mailto:info@peerless-av.com)



ONLINE: [www.peerless-av.com](http://www.peerless-av.com)



FLAT PANEL MOUNTS

## MODELS

### Dedicated Models:

Includes theft resistant hardware for attaching display to mount  
Display adapter purchased separately\*

<b>SF16D</b>	Black	for up to 16" studs
<b>SF24D</b>	Black	for up to 24" studs

\*Dedicated adapter plates come in flat black and include security fasteners

## DISPLAY ADAPTER

**Dedicated Models:** Requires display-specific PLP or LC adapter to be purchased separately.

## SPECIFICATIONS

	<b>Distance from Wall</b>	1.18" (30mm)
	<b>Max Load</b>	200lb (90kg)
<b>Product Dimensions (W x H x D)</b>		
	<b>SF16D:</b>	19.25" x 9.83" x 1.18" (489 x 250 x 30mm)
	<b>SF24D:</b>	30.75" x 9.83" x 1.18" (781 x 250 x 30mm)
<b>Mounting Surfaces</b>		
		Wood stud, concrete, cinder block and metal stud (Metal stud accessory required)
<b>Ship Weight</b>		
	<b>SF16D:</b>	7.4lb (3.4kg)
	<b>SF24D:</b>	9.3lb (4.2kg)

## CERTIFICATIONS



## ACCESSORIES



**ACC415:**  
4-pack Metal Stud Fastener Kit ..... pg# 196



# Display-Specific Tilt Wall Mount

For up to 71" Flat Panel Displays

## MODELS

### Dedicated Models:

Includes theft resistant hardware for attaching display to mount  
Display adapter purchased separately\*

<b>ST16D</b>	Black	for up to 16" studs
<b>ST24D</b>	Black	for up to 24" studs

\* Dedicated adapter plates come in flat black and include security fasteners

## DISPLAY ADAPTER

**Dedicated Models:** Requires display-specific PLP or LC adapter to be purchased separately.

## SPECIFICATIONS

	<b>Distance from Wall</b>	3.01" (76mm)
	<b>Tilt</b>	+15/-5°
	<b>Max Load</b>	200lb (90kg)
<b>Product Dimensions (W x H x D)</b>		
<b>ST16D:</b>	19.25" x 10.48" x 3.01" (489 x 266 x 76mm)	
<b>ST24D:</b>	30.75" x 10.48" x 3.01" (781 x 266 x 76mm)	
<b>Mounting Surfaces</b>		
Wood stud, concrete, cinder block and metal stud (Metal stud accessory required)		
<b>Ship Weight</b>		
<b>ST16D:</b>	10.1lb (4.6kg)	
<b>ST24D:</b>	12.2lb (5.5kg)	

1. Tilt allows adjustment of +15/-5° without the use of tools
2. Horizontal display adjustment up to 8" (203mm) for centering display on wall
3. Included IncreLok™ feature offers fixed tilt lock in 5° increments when used
4. Easy-Glide™ design ensures display is securely attached to wall plate
5. Choose from 16" (406mm) only or 16"-24" (406-610mm) stud center wall plate
6. Fits any display-specific PLP or LC adapter plate
7. Model ST16D ships with 19.25" (489mm) wide wall plate, perfect for portrait style installations
8. Wall plate knockouts provide wall access, improving cable management options

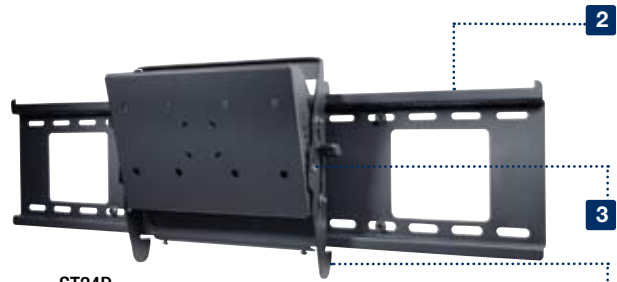

ST24D

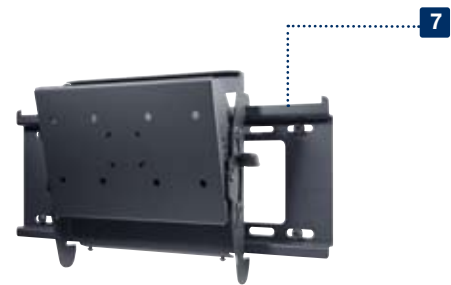

ST16D

Patented

## TECHNICAL DRAWINGS

For expanded product information and technical data visit [www.peerless-av.com](http://www.peerless-av.com)

## CERTIFICATIONS



## ACCESSORIES



**ACC415:**  
4-pack Metal Stud Fastener Kit ..... pg# 196

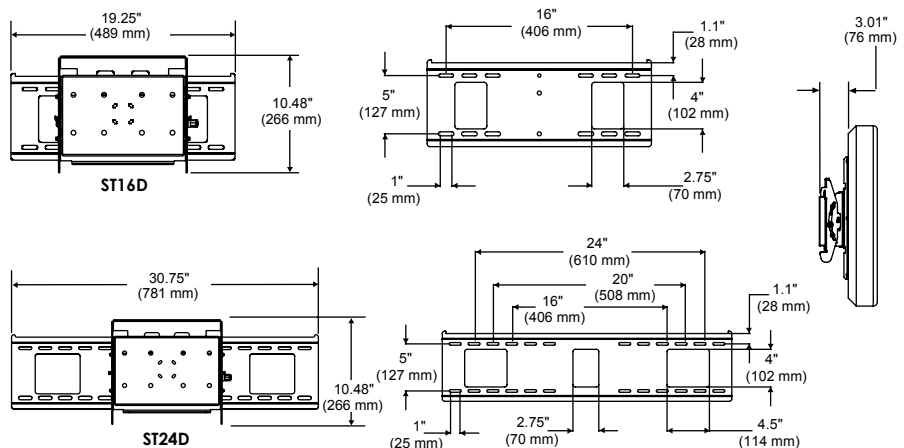

To verify mount compatibility with any flat panel display or projector model use MountFinder™ at [www.peerless-av.com](http://www.peerless-av.com)



CALL: 630-375-5100  
800-865-2112



FAX: 630-820-8537  
800-359-6500



E-MAIL: [info@peerless-av.com](mailto:info@peerless-av.com)



ONLINE: [www.peerless-av.com](http://www.peerless-av.com)

# Universal Flat Wall Mount

For 10" to 24" Flat Panel Displays

1. VESA® 75 and 100mm compliant
2. Low-profile design holds display 0.68" (17mm) from wall
3. Display adapter plate simply slides into the wall plate for a quick and easy installation



For expanded product information and technical data visit [www.peerless-av.com](http://www.peerless-av.com)

## TECHNICAL DRAWINGS

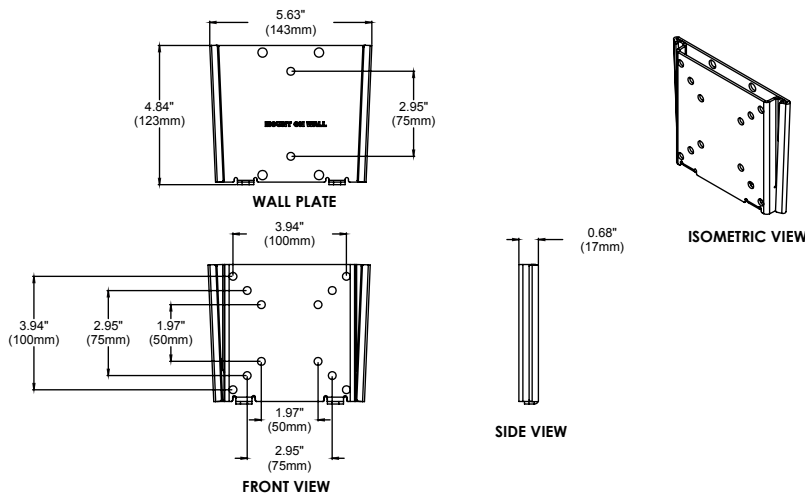

To verify mount compatibility with any flat panel display or projector model use MountFinder™ at [www.peerless-av.com](http://www.peerless-av.com)



CALL: 630-375-5100  
800-865-2112



FAX: 630-820-8537  
800-359-6500



E-MAIL: [info@peerless-av.com](mailto:info@peerless-av.com)



ONLINE: [www.peerless-av.com](http://www.peerless-av.com)



FLAT PANEL MOUNTS

## MODELS

### Universal Models:

Includes standard hardware (hex or Phillips) for attaching display to mount

**PF630**

Gloss black

## DISPLAY ADAPTER



### VESA® Pattern

Universal Models: 75 and 100mm

## SPECIFICATIONS



### Distance from Wall

0.68" (17mm)



### Max Load

80lb (36kg)

### Product Dimensions (W x H x D)

5.63" x 4.84" x 0.68"  
(143 x 123 x 17mm)

### Mounting Surfaces

Wood stud, concrete, cinder block and metal stud  
(Metal stud accessory required)

### Ship Weight

1.7lb (.8kg)

## CERTIFICATIONS



## ACCESSORIES



### ACC925:

Security Fasteners ..... pg# 199



### ACC215:

2-pack Metal Stud Fastener Kit ..... pg# 196



# Universal Flat Wall Mount

For 22" to 40" Flat Panel Displays

## MODELS

### Universal Models:

Includes standard hardware (hex or Phillips) for attaching display to mount

**PF632** Gloss black

## DISPLAY ADAPTER

### VESA® Pattern

Universal Models: 75, 100, 200 x 100 and 200 x 200mm

## SPECIFICATIONS

### Distance from Wall

0.73" (19mm)

### Max Load

115lb (52kg)

### Product Dimensions (W x H x D)

10.43" x 8.67" x 0.73"  
(265 x 220 x 19mm)

### Mounting Surfaces

Wood stud, concrete, cinder block and metal stud  
(Metal stud accessory required)

### Ship Weight

5.1lb (2.5kg)

## CERTIFICATIONS



**RoHS**  
2002/95/EC

## ACCESSORIES



**ACC925:**  
Security Fasteners ..... pg# 199



**ACC215:**  
2-pack Metal Stud  
Fastener Kit ..... pg# 196

1. VESA® 75, 100, 200 x 100 and 200 x 200mm compliant
2. Low-profile design holds display 0.73" (19mm) from wall
3. Display adapter plate simply slides into the wall plate for a quick and easy installation



## TECHNICAL DRAWINGS

For expanded product information and technical data visit [www.peerless-av.com](http://www.peerless-av.com)

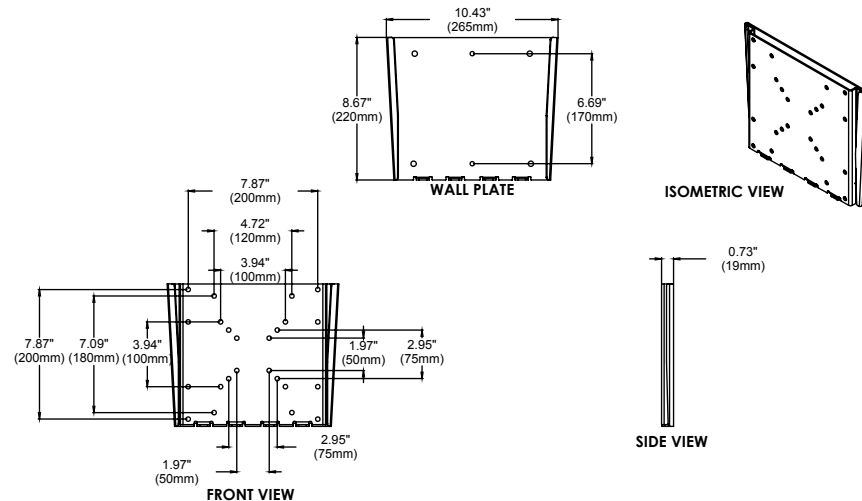

To verify mount compatibility with any flat panel display or projector model use MountFinder™ at [www.peerless-av.com](http://www.peerless-av.com)



CALL: 630-375-5100  
800-865-2112



FAX: 630-820-8537  
800-359-6500



E-MAIL: [info@peerless-av.com](mailto:info@peerless-av.com)



ONLINE: [www.peerless-av.com](http://www.peerless-av.com)

# Universal Flat Wall Mount

For 23" to 46" Flat Panel Displays

1. Low-profile design holds display only 1.18" (30mm) from the wall
2. Horizontal display adjustment up to 6" (152mm) for centering display on wall
3. Universal display adapters easily hook onto wall plate for a quick installation
4. Easy-Glide™ design ensures display is properly attached to the wall plate
4. Wall plate knockouts provide wall access, improving cable management options

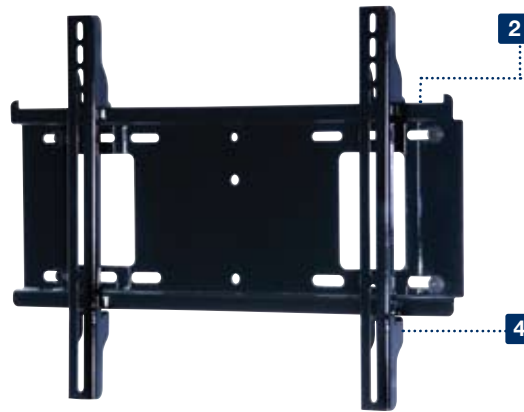

For expanded product information and technical data visit [www.peerless-av.com](http://www.peerless-av.com)

## TECHNICAL DRAWINGS

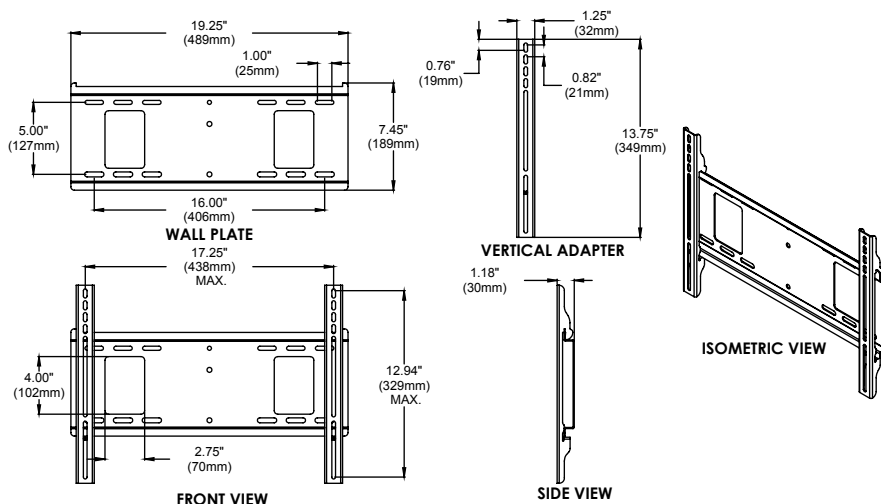

FLAT PANEL MOUNTS

## MODELS

### Universal Models:

Includes standard hardware (hex or Phillips) for attaching display to mount

**PF640**

Gloss black

## DISPLAY ADAPTER



### Mounting Pattern

Universal Models: 438 x 329mm (17.25"W x 12.94"H)

Many 42" flat panel displays have mounting hole patterns larger than dimensions above. Use MountFinder™ to verify mount compatibility.



### VESA® Pattern

Universal Models: Up to 400 x 300mm

## SPECIFICATIONS



### Distance from Wall

1.18" (30mm)



### Max Load

150lb (68kg)

### Product Dimensions (W x H x D)

19.25" x 13.75" x 1.18" (489 x 349 x 30mm)

### Mounting Surfaces

Wood stud, concrete, cinder block and metal stud (Metal stud accessory required)

### Ship Weight

5.6lb (2.5kg)

## CERTIFICATIONS



## ACCESSORIES



### ACC925:

Security Fasteners ..... pg# 199



### ACC415:

4-pack Metal Stud Fastener Kit ..... pg# 196

To verify mount compatibility with any flat panel display or projector model use MountFinder™ at [www.peerless-av.com](http://www.peerless-av.com)



CALL: 630-375-5100  
800-865-2112



FAX: 630-820-8537  
800-359-6500



E-MAIL: [info@peerless-av.com](mailto:info@peerless-av.com)



ONLINE: [www.peerless-av.com](http://www.peerless-av.com)





# Universal Flat Wall Mount

For 37" to 60" Flat Panel Displays

## MODELS

### Universal Models:

Includes standard hardware (hex or Phillips) for attaching display to mount

**PF660**      Gloss black

## DISPLAY ADAPTER

### Mounting Pattern

Universal Models: 730 x 433mm  
(28.75"W x 17.05"H)

### VESA® Pattern

Universal Models: Up to 600 x 400mm

## SPECIFICATIONS

### Distance from Wall

1.68" (43mm)

### Max Load

200lb (90kg)

### Product Dimensions (W x H x D)

30.75" x 18.00" x 1.68"  
(781 x 457 x 43mm)

### Mounting Surfaces

Wood stud, concrete, cinder block and metal stud  
(Metal stud accessory required)

### Ship Weight

9.88lb (4.5kg)

1. Wall plate knockouts provide additional wall access for improved power and cable management
2. Low-profile design holds display only 1.68" (43mm) from the wall
3. Horizontal display adjustment up to 8" (203mm) for centering display on wall
4. Universal display adapters easily hook onto wall plate for a quick installation
5. Easy-Glide™ design ensures display is properly attached to the wall plate

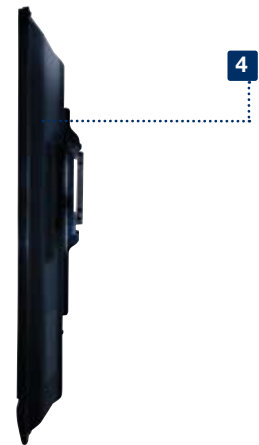
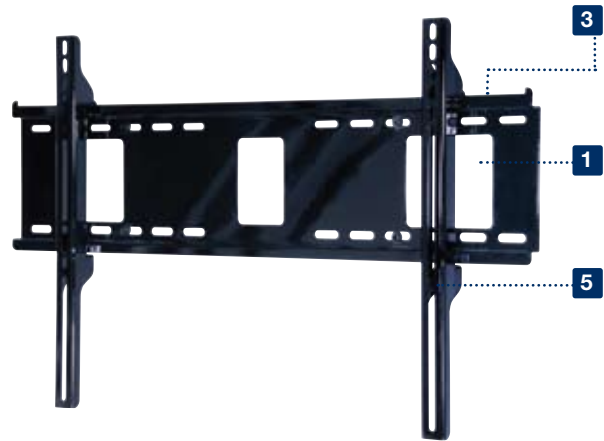

## CERTIFICATIONS



## TECHNICAL DRAWINGS

For expanded product information and technical data visit [www.peerless-av.com](http://www.peerless-av.com)

## ACCESSORIES



**ACC925:**  
Security Fasteners ..... pg# 199



**ACC415:**  
4-pack Metal Stud  
Fastener Kit ..... pg# 196

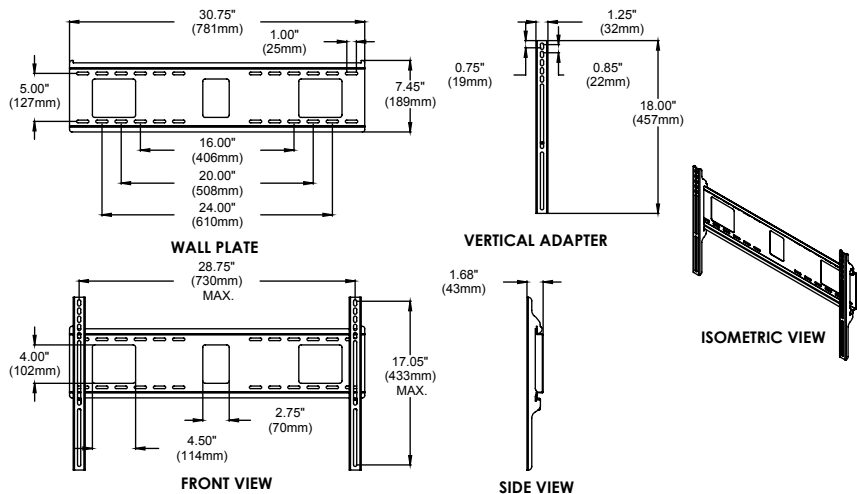

To verify mount compatibility with any flat panel display or projector model use MountFinder™ at [www.peerless-av.com](http://www.peerless-av.com)

CALL: 630-375-5100  
800-865-2112

FAX: 630-820-8537  
800-359-6500

E-MAIL:  
[info@peerless-av.com](mailto:info@peerless-av.com)

ONLINE:  
[www.peerless-av.com](http://www.peerless-av.com)

# Universal Tilt Wall Mount

For 10" to 24" Flat Panel Displays

1. VESA® 75 and 100mm compliant
2. +15/-5° tilt adjustment for finding the perfect viewing angle
3. Low-profile design holds display 2.10" (53mm) from wall
4. Display adapter plate simply slides onto the wall plate for a quick and easy installation

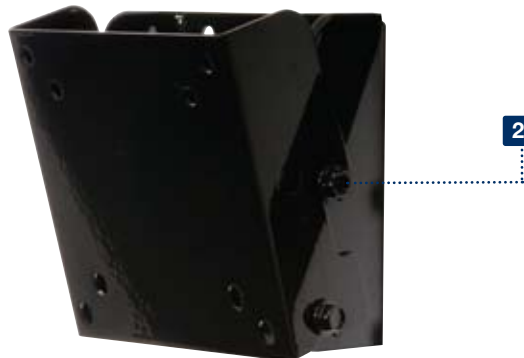

FLAT PANEL MOUNTS

## MODELS

### Universal Models:

Includes standard hardware (hex or Phillips) for attaching display to mount

**PT630** Gloss black

## DISPLAY ADAPTER



### VESA® Pattern

Universal Models: 75 and 100mm

## SPECIFICATIONS



### Distance from Wall

2.10"-3.17" (53-81mm)



### Tilt

+15/-5°



### Max Load

80lb (36kg)

### Product Dimensions (W x H x D)

5.46" x 4.75" x 2.10"-3.17"  
(139 x 121 x 53-81mm)

### Mounting Surfaces

Wood stud, concrete, cinder block and metal stud  
(Metal stud accessory required)

### Ship Weight

2.2lb (0.99kg)

For expanded product information and technical data visit [www.peerless-av.com](http://www.peerless-av.com)

## TECHNICAL DRAWINGS

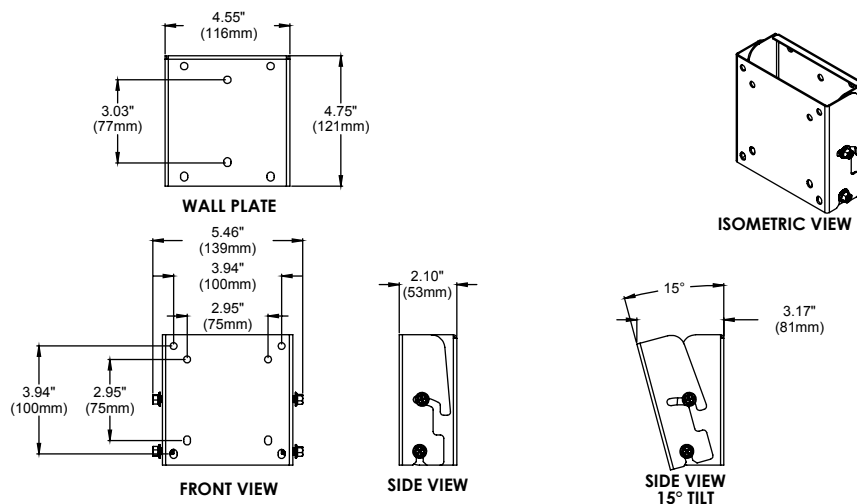

## CERTIFICATIONS



## ACCESSORIES



### ACC925:

Security Fasteners ..... pg# 199



### ACC215:

2-pack Metal Stud Fastener Kit ..... pg# 196

To verify mount compatibility with any flat panel display or projector model use MountFinder™ at [www.peerless-av.com](http://www.peerless-av.com)



CALL: 630-375-5100  
800-865-2112



FAX: 630-820-8537  
800-359-6500



E-MAIL:  
[info@peerless-av.com](mailto:info@peerless-av.com)



ONLINE:  
[www.peerless-av.com](http://www.peerless-av.com)



# Universal Tilt Wall Mount

For 22" to 40" Flat Panel Displays

## MODELS

### Universal Models:

Includes standard hardware (hex or Phillips) for attaching display to mount

**PT632** Gloss black

## DISPLAY ADAPTER

### VESA® Pattern

Universal Models: 75, 100, 200 x 100 and 200 x 200mm

## SPECIFICATIONS

	<b>Distance from Wall</b>
	2.18"-3.84" (55-98mm)
	<b>Tilt</b>
	+15/-5°
	<b>Max Load</b>
	115lb (52kg)
	<b>Product Dimensions (W x H x D)</b>
	8.75" x 9.35" x 2.18"-3.84" (222 x 237 x 55-98mm)
	<b>Mounting Surfaces</b>
	Wood stud, concrete, cinder block and metal stud (Metal stud accessory required)
	<b>Ship Weight</b>
	3.5lb (1.6kg)

## CERTIFICATIONS



## ACCESSORIES

**ACC925:** Security Fasteners ..... pg# 199

**ACC215:** 2-pack Metal Stud Fastener Kit ..... pg# 196

1. VESA® 75, 100, 200 x 100 and 200 x 200mm compliant
2. +15/-5° tilt adjustment for finding the perfect viewing angle
3. Low-profile design holds display 2.18" (55mm) from wall
4. Display adapter plate simply slides onto the wall plate for a quick and easy installation
5. Compatible with flat panels that use M8 screws

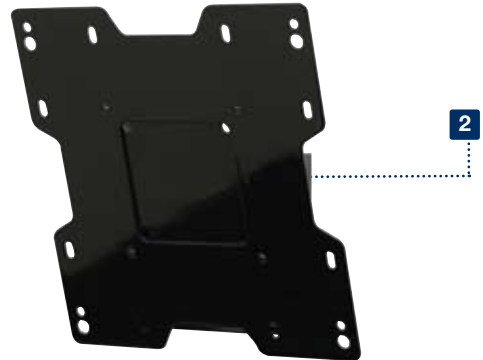

## TECHNICAL DRAWINGS

For expanded product information and technical data visit [www.peerless-av.com](http://www.peerless-av.com)

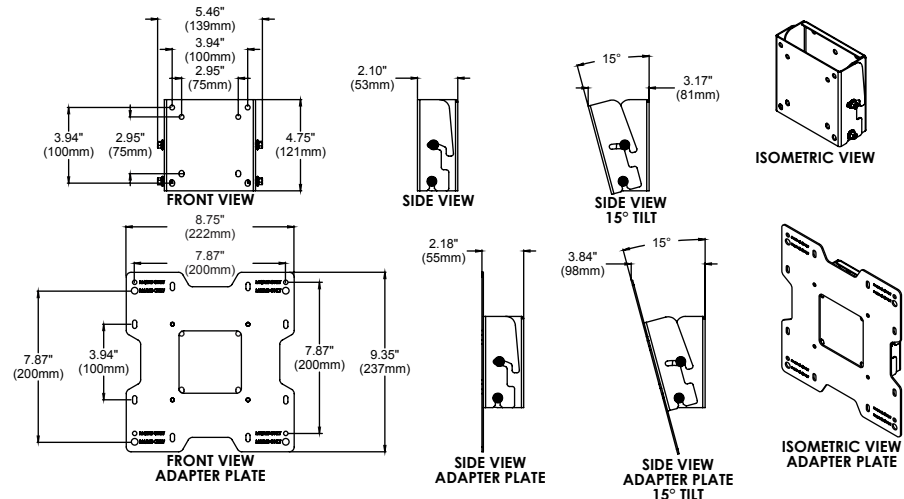

To verify mount compatibility with any flat panel display or projector model use MountFinder™ at [www.peerless-av.com](http://www.peerless-av.com)



**CALL:** 630-375-5100  
800-865-2112



**FAX:** 630-820-8537  
800-359-6500



**E-MAIL:**  
[info@peerless-av.com](mailto:info@peerless-av.com)



**ONLINE:**  
[www.peerless-av.com](http://www.peerless-av.com)

# Universal Tilt Wall Mount

For 23" to 46" Flat Panel Displays

1. +15/-5° tilt adjustment for finding the perfect viewing angle
2. Included InceLok™ feature offers fixed tilt lock in 5° increments when used
3. Wall plate knockouts provide additional wall access for improved power and cable management
4. Horizontal display adjustment up to 6" (152mm) for centering display on wall
5. Universal display adapters easily hook onto wall plate for a quick installation
6. Easy-Glide™ design ensures display is properly attached to the wall plate

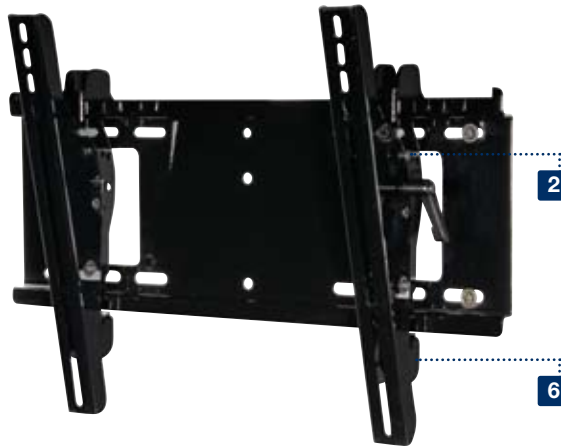

Patented

For expanded product information and technical data visit [www.peerless-av.com](http://www.peerless-av.com)

## TECHNICAL DRAWINGS

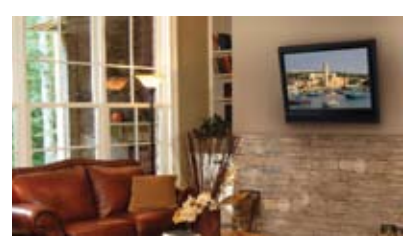
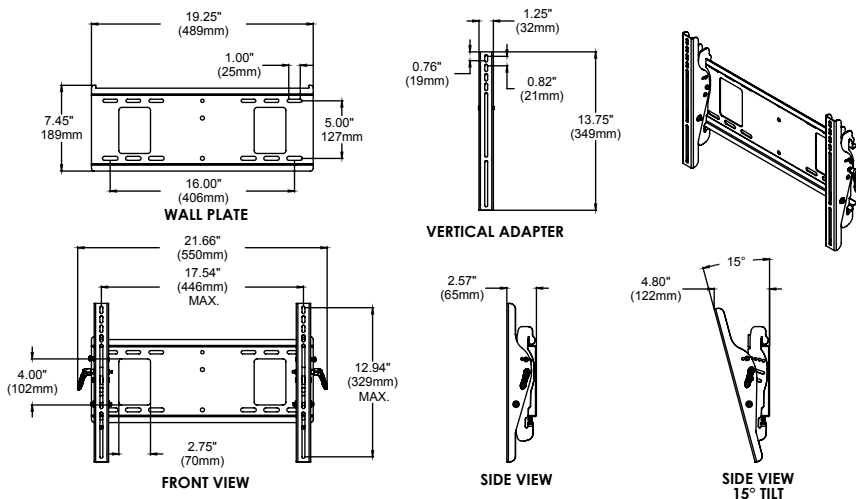

FLAT PANEL MOUNTS

## MODELS

### Universal Models:

Includes standard hardware (hex or Phillips) for attaching display to mount

**PT640**

Gloss black

## DISPLAY ADAPTER



### Mounting Pattern

Universal Models: 446 x 329mm  
17.54"W x 12.94"H

Many 42" flat panel displays have mounting hole patterns larger than dimensions above. Use MountFinder™ to verify mount compatibility.



### VESA® Pattern

Universal Models: Up to 400 x 300mm

## SPECIFICATIONS



### Distance from Wall

2.57"-4.80" (65-122mm)



### Tilt

+15/-5°



### Max Load

150lb (68kg)

### Product Dimensions (W x H x D)

21.66" x 13.75" x 2.57"-4.80"  
(550 x 349 x 65-122mm)

### Mounting Surfaces

Wood stud, concrete, cinder block and metal stud  
(Metal stud accessory required)

### Ship Weight

8lb (3.6kg)

## CERTIFICATIONS



## ACCESSORIES



### ACC925:

Security Fasteners ..... pg# 199



### ACC415:

4-pack Metal Stud Fastener Kit ..... pg# 196

To verify mount compatibility with any flat panel display or projector model use MountFinder™ at [www.peerless-av.com](http://www.peerless-av.com)



CALL: 630-375-5100  
800-865-2112



FAX: 630-820-8537  
800-359-6500



E-MAIL: [info@peerless-av.com](mailto:info@peerless-av.com)



ONLINE: [www.peerless-av.com](http://www.peerless-av.com)



# Universal Tilt Wall Mount

For 37" to 60" Flat Panel Displays

## MODELS

### Universal Models:

Includes standard hardware (hex or Phillips) for attaching display to mount

**PT660** Gloss black

## DISPLAY ADAPTER

### Mounting Pattern

Universal Models: 738 x 449mm  
(29.04"W x 17.67"H)

### VESA® Pattern

Universal Models: Up to 600 x 400mm

## SPECIFICATIONS

### Distance from Wall

2.56"-5.64" (65-143mm)

### Tilt

+15/-5°

### Max Load

200lb (90kg)

### Product Dimensions (W x H x D)

33.16" x 18.5" x 2.56"-5.64"  
(842 x 470 x 65-143mm)

### Mounting Surfaces

Wood stud, concrete, cinder block and metal stud  
(Metal stud accessory required)

### Ship Weight

10.5lb (4.7kg)

- +15/-5° tilt adjustment for finding the perfect viewing angle
- Included InceLok™ feature offers fixed tilt lock in 5° increments when used
- Wall Plate knockouts provide additional wall access for improved power and cable management
- Horizontal display adjustment up to 8" (203mm) for centering display on wall
- Universal display adapters easily hook onto wall plate for a quick installation
- Easy-Glide™ design ensures display is properly attached to the wall plate



Patented

## CERTIFICATIONS



## TECHNICAL DRAWINGS

For expanded product information and technical data visit [www.peerless-av.com](http://www.peerless-av.com)

## ACCESSORIES



**ACC925:**  
Security Fasteners ..... pg# 199



**ACC415:**  
4-pack Metal Stud  
Fastener Kit ..... pg# 196

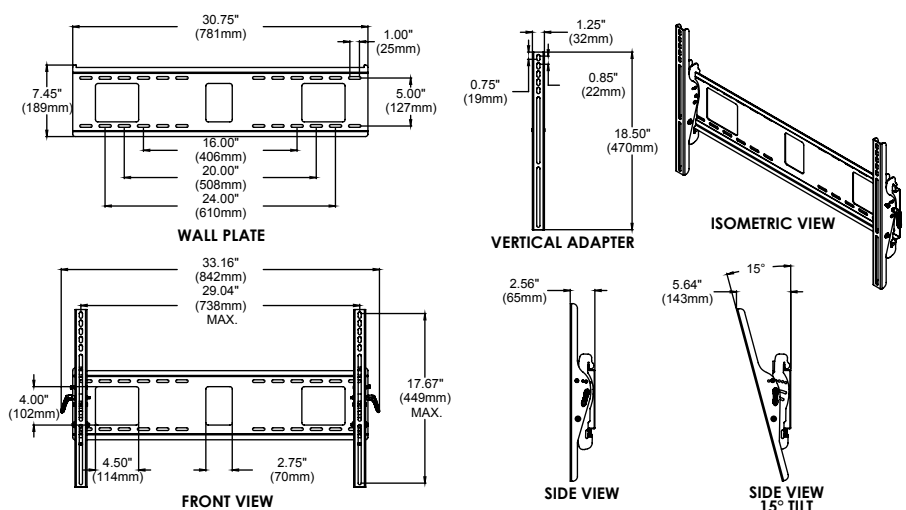

To verify mount compatibility with any flat panel display or projector model use MountFinder™ at [www.peerless-av.com](http://www.peerless-av.com)



# Universal Fixed Tilt Wall Mount

For 23" to 60" Flat Panel Displays

1. Single rail design enables quick and simple installation
2. Low-profile design holds display 2.00" (51mm) from the wall with PFT660 models and 1.70" (43mm) from the wall with PFT640
3. Safety tab ensures display is securely attached to wall plate
4. Horizontal display adjustment up to 8" (203mm) for centering display on wall
5. Integrated fixed tilt angles of 0°, 2°, 5°, and 10° provide a variety of viewing angle options

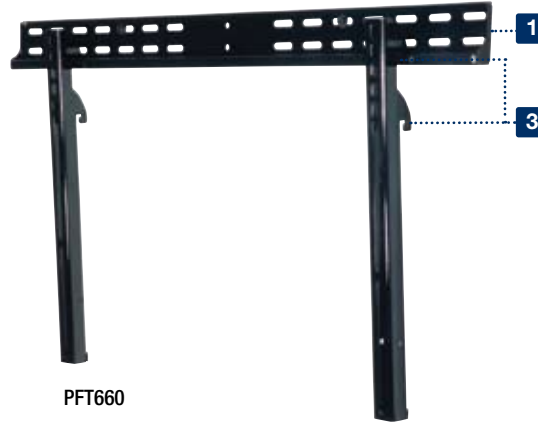

PFT660



PFT640



0° 2° 5° 10°

Patented

For expanded product information and technical data visit [www.peerless-av.com](http://www.peerless-av.com)

## TECHNICAL DRAWINGS

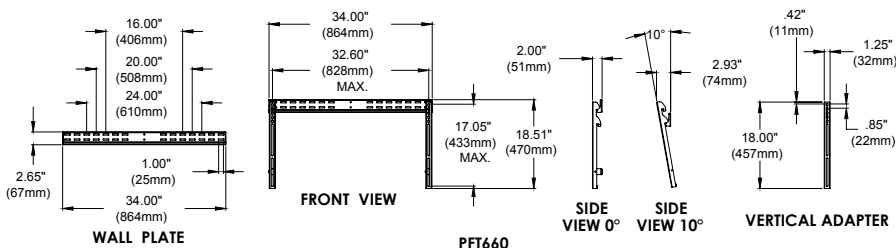
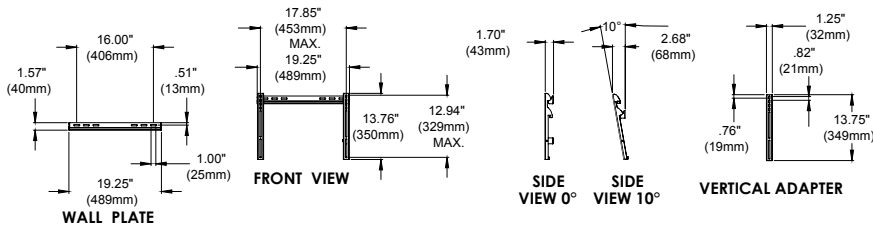

To verify mount compatibility with any flat panel display or projector model use MountFinder™ at [www.peerless-av.com](http://www.peerless-av.com)



CALL: 630-375-5100  
800-865-2112



FAX: 630-820-8537  
800-359-6500



E-MAIL: [info@peerless-av.com](mailto:info@peerless-av.com)



ONLINE: [www.peerless-av.com](http://www.peerless-av.com)



FLAT PANEL MOUNTS

## MODELS

### Universal Models:

Includes standard hardware (hex or Phillips) for attaching display to mount

**PFT640** Glass black for 23" to 46" screens  
**PFT660** Glass black for 37" to 60" screens

## DISPLAY ADAPTER



### Mounting Pattern

#### Universal Models

**PFT640:** 453 x 329mm\*  
(17.85"W x 12.94"H)

**PFT660:** 828 x 433mm  
(32.60"W x 17.05"H)

\* Many flat panel displays have mounting hole patterns larger than dimensions above. Use MountFinder™ to verify mount compatibility.



### VESA® Pattern

#### Universal Models

**PFT640:** Up to 400 x 300mm

**PFT660:** Up to 800 x 400mm

## SPECIFICATIONS



### Distance from Wall

**PFT640:** 1.70"-2.68" (43-68mm)  
**PFT660:** 2.00"-2.93" (51-74mm)



### Tilt

0°, 2°, 5°, 10°



### Max Load

**PFT640:** 100lb (45kg)  
**PFT660:** 175lb (79kg)

### Product Dimensions (W x H x D)

**PFT640:** 19.25" x 13.76" x 1.70"-2.68"  
(489 x 350 x 43-68mm)

**PFT660:** 34.00" x 18.51" x 2.00"-2.93"  
(864 x 470 x 51-74mm)

### Mounting Surfaces

Wood stud, concrete, cinder block and metal stud  
(Metal stud accessory required)

### Ship Weight

**PFT640:** 3.8lb (1.72kg)  
**PFT660:** 7lb (3.1kg)

## CERTIFICATIONS



## ACCESSORIES



**ACC215:** (for PFT640)  
2-pack Metal Stud  
Fastener Kit ..... pg# 196



**ACC415:** (for PFT660)  
4-pack Metal Stud  
Fastener Kit ..... pg# 196



# Pivot Wall Mount

For 10" to 24" Flat Panel Displays

## MODELS

### Universal Models:

Includes standard hardware (hex or Phillips) for attaching display to mount

<b>PP730</b>	Gloss black
<b>PP730-S</b>	Gloss silver

## DISPLAY ADAPTER

### VESA® Pattern

Universal Models: 75 and 100mm

## SPECIFICATIONS

### Distance from Wall

2.36"-7.01" (60-178mm)

### Tilt | Swivel | Roll

±35° | ±90° | ±5°

### Max Load

25lb (11kg)

### Product Dimensions (W x H x D)

8.11" x 5.50" x 2.36"-7.01"  
(206 x 140 x 60-178mm)

### Mounting Surfaces

Wood stud, concrete, cinder block and metal stud  
(Metal stud accessory required)

### Ship Weight

2.2lb (1kg)

1. Arm extends up to 7.01" (178mm) from wall
2. Two tensioned pivot points for up to 180° of side-to-side swivel
3. One-Touch™ tilt mechanism offers up to ±35° of tilt
4. ±5° or roll for post installation display leveling
5. Integrated cable management keeps cables out of the way

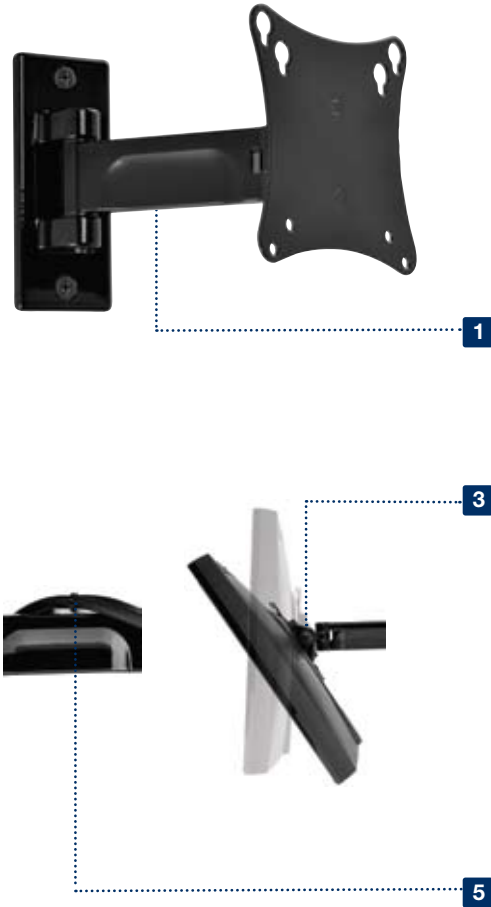

Patented

## CERTIFICATIONS



OSHPD Approval Pending

## ACCESSORIES



**ACC918:**  
Security Fasteners ..... pg# 199



**WSP700:**  
Metal Stud Wall Plate for 16" Center Metal Studs ... pg# 195



**WSP701:**  
Metal Stud Wall Plate for 20" and 24" Center Metal Studs ... pg# 195

## TECHNICAL DRAWINGS

For expanded product information and technical data visit [www.peerless-av.com](http://www.peerless-av.com)

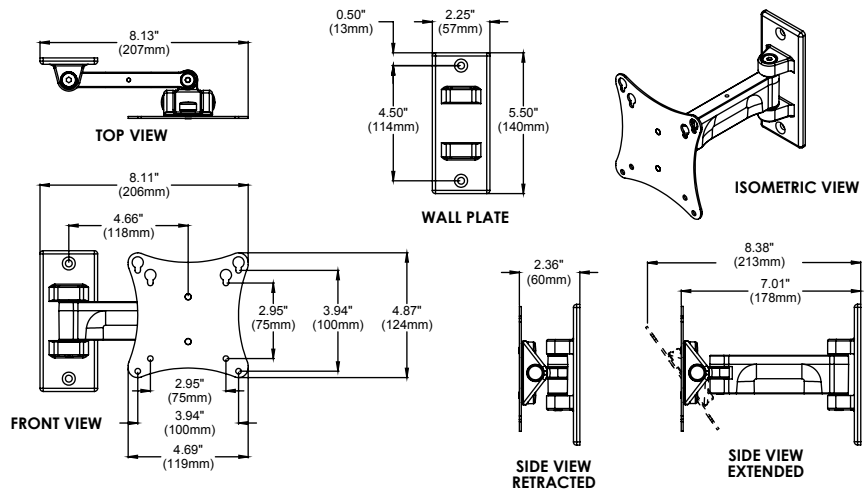

To verify mount compatibility with any flat panel display or projector model use MountFinder™ at [www.peerless-av.com](http://www.peerless-av.com)



CALL: 630-375-5100  
800-865-2112



FAX: 630-820-8537  
800-359-6500



E-MAIL: [info@peerless-av.com](mailto:info@peerless-av.com)



ONLINE: [www.peerless-av.com](http://www.peerless-av.com)

# Pivot Wall Mount

For 22" to 40" Flat Panel Displays

1. Arm extends up to 7.88" (200mm) from wall
2. Two tensioned pivot points for up to 180° of side-to-side swivel
3. Up to +15/-5° of tilt for the best viewing angle
4. ±5° of roll for post installation display leveling
5. Integrated cable management keeps cables out of the way
6. Compatible with flat panels that use M8 screws

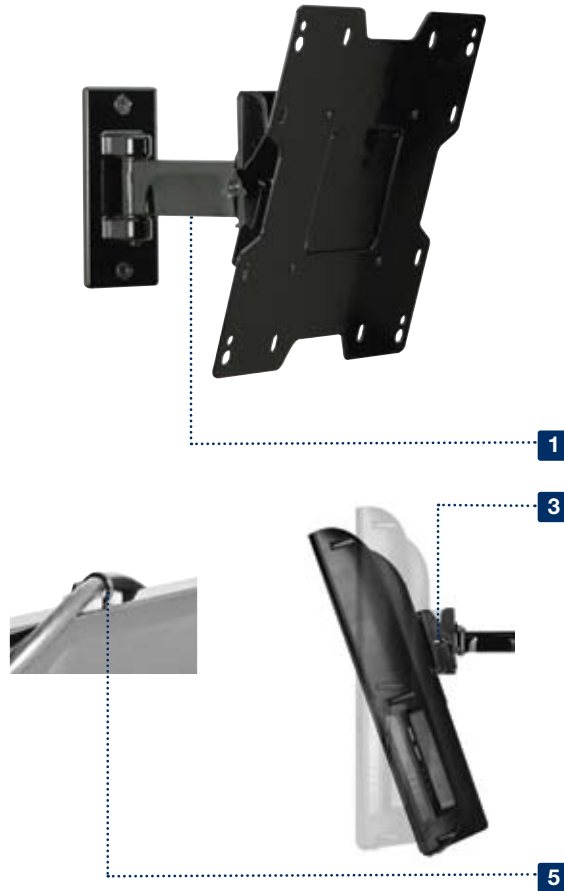

Patented

For expanded product information and technical data visit [www.peerless-av.com](http://www.peerless-av.com)

## TECHNICAL DRAWINGS

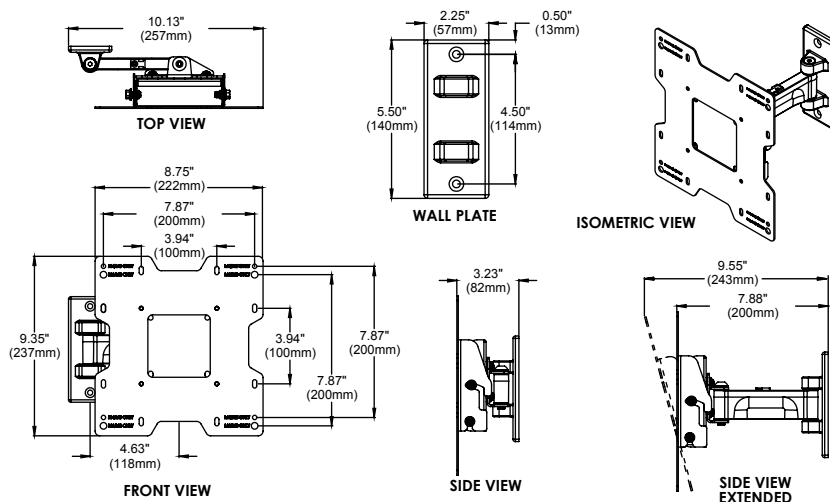

## MODELS

### Universal Models:

Includes standard hardware (hex or Phillips) for attaching display to mount

<b>PP740</b>	Gloss black
<b>PP740-S</b>	Gloss silver

## DISPLAY ADAPTER



### VESA® Pattern

Universal Models:	75, 100, 200 x 100 and 200 x 200mm
-------------------	------------------------------------

## SPECIFICATIONS



### Distance from Wall

3.23"-7.88" (82-200mm)



### Tilt | Swivel | Roll

+15/-5° | ±90° | ±7°



### Max Load

80lb (36kg)

### Product Dimensions (W x H x D)

10.13" x 9.35" x 3.23"-7.88"  
(257 x 237 x 82-200mm)

### Mounting Surfaces

Wood stud, concrete, cinder block and metal stud  
(Metal stud accessory required)

### Ship Weight

3.84lb (1.74kg)

## CERTIFICATIONS



OSHPD Approval Pending

## ACCESSORIES



**ACC919:**  
Security Fasteners ..... pg# 199



**WSP700:**  
Metal Stud Wall Plate  
for 16" Center Metal Studs ... pg# 195



**WSP701:**  
Metal Stud Wall Plate for 20"  
and 24" Center Metal Studs .. pg# 195

To verify mount compatibility with any flat panel display or projector model use MountFinder™ at [www.peerless-av.com](http://www.peerless-av.com)



CALL: 630-375-5100  
800-865-2112



FAX: 630-820-8537  
800-359-6500



E-MAIL:  
[info@peerless-av.com](mailto:info@peerless-av.com)



ONLINE:  
[www.peerless-av.com](http://www.peerless-av.com)



# Articulating Wall Arm

For 10" to 24" Flat Panel Displays

## MODELS

### Universal Models:

Includes standard hardware (hex or Phillips) for attaching display to mount

<b>PA730</b>	Gloss black
<b>PA730-S</b>	Gloss silver

## DISPLAY ADAPTER

### VESA® Pattern

Universal Models: 75 and 100mm

## SPECIFICATIONS

### Distance from Wall

2.42"-14.46" (61-367mm)

### Tilt | Swivel | Roll

±35° | ±90° | ±5°

### Max Load

25lb (11kg)

### Product Dimensions (W x H x D)

8.58" x 7.04" x 2.42"-14.46"  
(218 x 179 x 61-367mm)

### Mounting Surfaces

Wood stud, concrete, cinder block and metal stud  
(Metal stud accessory required)

### Ship Weight

2.82lb (1.3kg)

1. Arm extends up to 14.46" (367mm) from wall
2. Three adjustable pivot points for versatile display positioning
3. One-Touch™ tilt mechanism offers up to ±35° of tilt
4. ±5° of roll for post installation display leveling
5. Integrated cable management keeps cables out of the way



Patented

## CERTIFICATIONS



## ACCESSORIES



**ACC918:** Security Fasteners ..... pg# 199



**WSP700:** Metal Stud Wall Plate for 16" Center Metal Studs ... pg# 195



**WSP701:** Metal Stud Wall Plate for 20" and 24" Center Metal Studs ... pg# 195

## TECHNICAL DRAWINGS

For expanded product information and technical data visit [www.peerless-av.com](http://www.peerless-av.com)

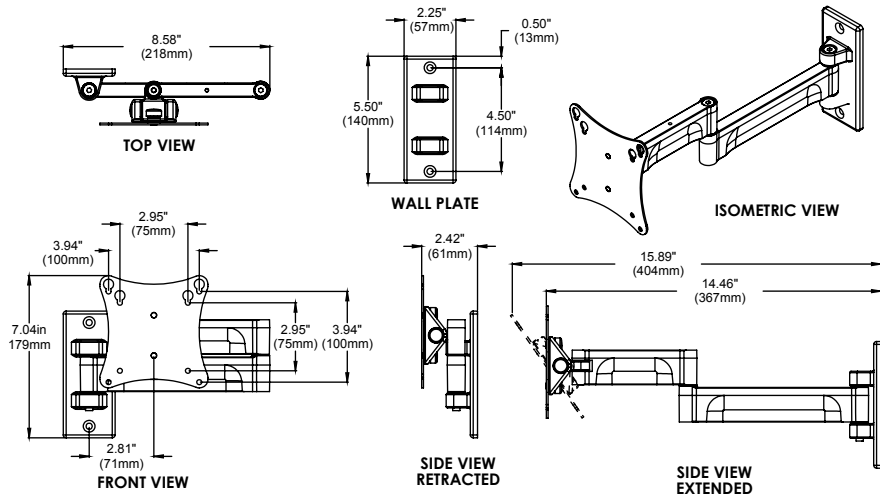

To verify mount compatibility with any flat panel display or projector model use MountFinder™ at [www.peerless-av.com](http://www.peerless-av.com)



CALL: 630-375-5100  
800-865-2112



FAX: 630-820-8537  
800-359-6500



E-MAIL: [info@peerless-av.com](mailto:info@peerless-av.com)



ONLINE: [www.peerless-av.com](http://www.peerless-av.com)

# Articulating Wall Arm

For 10" to 26" Flat Panel Displays

1. Universal display adapters provide compatibility with displays with up to a VESA® 200 x 100mm mounting hole pattern
2. Arm extends up to 14.74" (374mm) from wall
3. Three adjustable pivot points for versatile display positioning
4. ±5° of roll for post installation display leveling
5. Integrated cable management keeps cables out of the way
6. Display is centered on wall plate

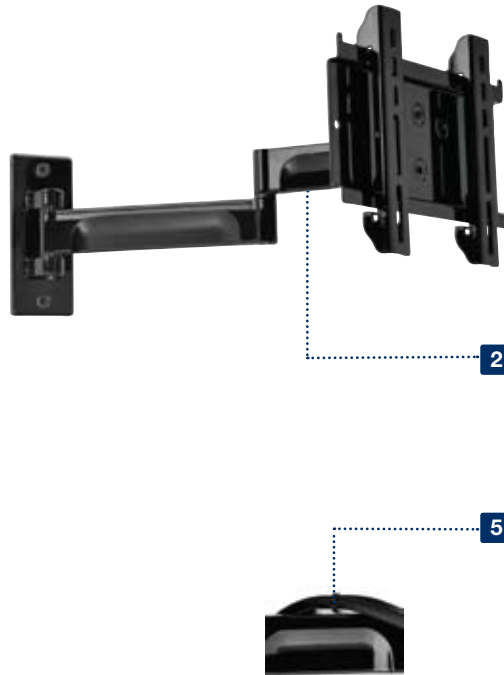

Patented

For expanded product information and technical data visit [www.peerless-av.com](http://www.peerless-av.com)

## TECHNICAL DRAWINGS

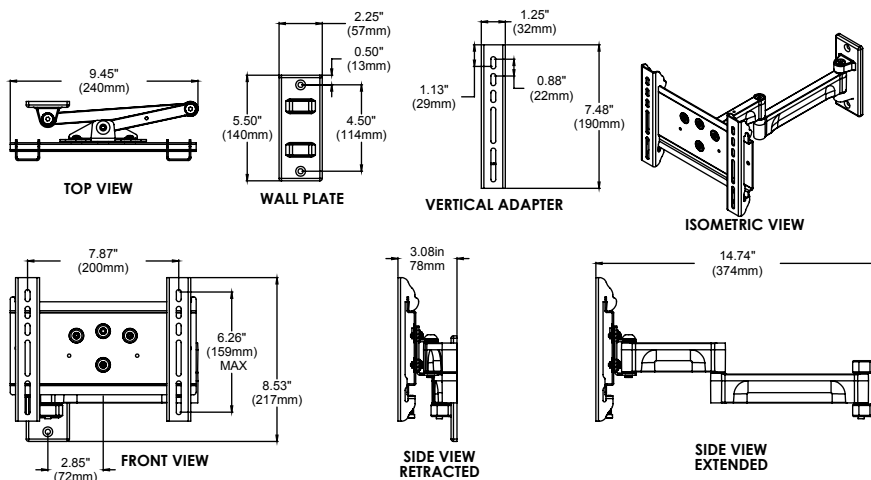

To verify mount compatibility with any flat panel display or projector model use MountFinder™ at [www.peerless-av.com](http://www.peerless-av.com)



CALL: 630-375-5100  
800-865-2112



FAX: 630-820-8537  
800-359-6500



E-MAIL: [info@peerless-av.com](mailto:info@peerless-av.com)



ONLINE: [www.peerless-av.com](http://www.peerless-av.com)



FLAT PANEL MOUNTS

## MODELS

### Universal Models:

Includes standard hardware (hex or Phillips) for attaching display to mount

**PA735F** Gloss black  
**PA735F-S** Gloss silver

## DISPLAY ADAPTER



### Mounting Pattern

Universal Models: 200 x 159mm  
(7.87"W x 6.26"H)



### VESA® Pattern

Universal Models: Up to 200 x 100mm

## SPECIFICATIONS



### Distance from Wall

3.08"-14.74" (78-374mm)



### Swivel | Roll

±90° | ±5°



### Max Load

25lb (11kg)

### Product Dimensions (W x H x D)

9.77" x 8.53" x 3.08"-14.74"  
(248 x 217 x 78-374mm)

### Mounting Surfaces

Wood stud, concrete, cinder block and metal stud  
(Metal stud accessory required)

### Ship Weight

4.1lb (1.8kg)

## CERTIFICATIONS



## ACCESSORIES



**ACC919:** Security Fasteners ..... pg# 199



**WSP700:** Metal Stud Wall Plate for 16" Center Metal Studs ... pg# 195



**WSP701:** Metal Stud Wall Plate for 20" and 24" Center Metal Studs .. pg# 195





# Articulating Wall Arm

For 22" to 40" Flat Panel Displays

## MODELS

### Universal Models:

Includes standard hardware (hex or Phillips) for attaching display to mount

<b>PA740</b>	Gloss black
<b>PA740-S</b>	Gloss silver

## DISPLAY ADAPTER

### VESA® Pattern

Universal Models: 75, 100, 200 x 100 and 200 x 200mm

## SPECIFICATIONS

	<b>Distance from Wall</b>	3.27"-15.37" (83-390mm)
	<b>Tilt   Swivel   Roll</b>	+15/-5°   ±90°   ±5°
	<b>Max Load</b>	80lb (36kg)
	<b>Product Dimensions (W x H x D)</b>	9.42" x 9.35" x 3.27"-15.37" (239 x 237 x 83-390mm)
	<b>Mounting Surfaces</b>	Wood stud, concrete, cinder block and metal stud (Metal stud accessory required)
	<b>Ship Weight</b>	5.89lb (2.67kg)

## CERTIFICATIONS



OSHDP Approval Pending

## ACCESSORIES



**ACC919:** Security Fasteners ..... pg# 199



**WSP700:** Metal Stud Wall Plate for 16" Center Metal Studs ... pg# 195



**WSP701:** Metal Stud Wall Plate for 20" and 24" Center Metal Studs .. pg# 195

1. Arm extends up to 15.37" (390mm) from wall
2. Three adjustable pivot points for versatile display positioning
3. Up to +15/-5° of tilt for the best viewing angle
4. ±5° of roll for post installation display leveling
5. Integrated cable management keeps cables out of the way
6. Compatible with flat panels that use M8 screws

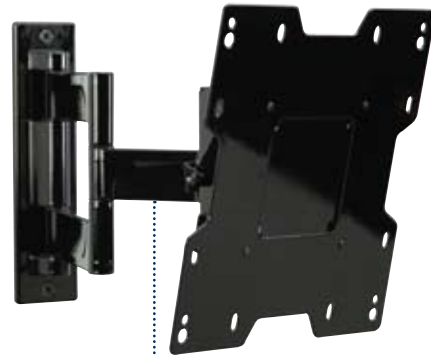

1

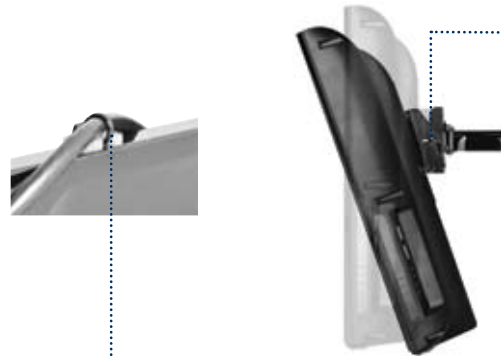

3

5

Patented

## TECHNICAL DRAWINGS

For expanded product information and technical data visit [www.peerless-av.com](http://www.peerless-av.com)

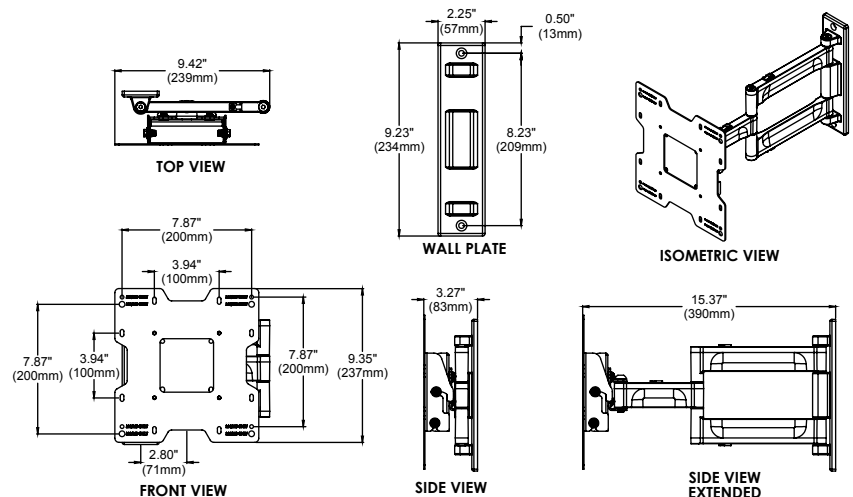

To verify mount compatibility with any flat panel display or projector model use MountFinder™ at [www.peerless-av.com](http://www.peerless-av.com)



CALL: 630-375-5100  
800-865-2112



FAX: 630-820-8537  
800-359-6500



E-MAIL: [info@peerless-av.com](mailto:info@peerless-av.com)



ONLINE: [www.peerless-av.com](http://www.peerless-av.com)

# Articulating Wall Arm

For 26" to 46" Flat Panel Displays

1. Universal display adapters provide compatibility with displays with up to a VESA® 400 x 400mm mounting hole pattern
2. Arm extends up to 14.74" (374mm) from wall
3. Three adjustable pivot points for versatile display positioning
4. ±5° of roll for post installation display leveling
5. Integrated cable management keeps cables and cords out of the way

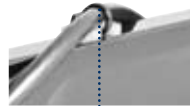

Patented

For expanded product information and technical data visit [www.peerless-av.com](http://www.peerless-av.com)

## TECHNICAL DRAWINGS

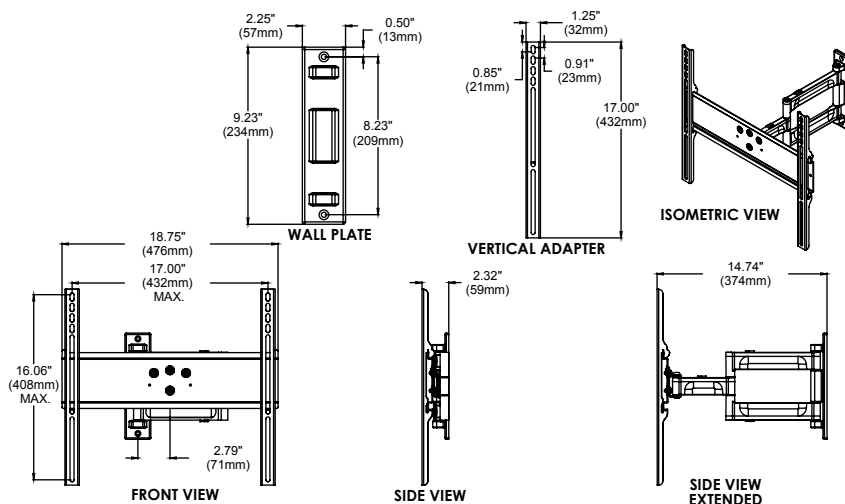

FLAT PANEL MOUNTS

## MODELS

### Universal Models:

Includes standard hardware (hex or Phillips) for attaching display to mount

<b>PA746F</b>	Gloss black
<b>PA746F-S</b>	Gloss silver

## DISPLAY ADAPTER



### Mounting Pattern

Universal Models:	432 x 408mm (17\"W x 16.06\"H)
-------------------	-----------------------------------



### VESA® Pattern

Universal Models:	Up to 400 x 400mm
-------------------	-------------------

## SPECIFICATIONS



### Distance from Wall

2.32"-14.74" (59-374mm)



### Swivel | Roll

±90° | ±5°



### Max load

80lb (36kg)

### Product Dimensions (W x H x D)

18.75" x 17.00" x 2.32"-14.74"  
(476 x 432 x 59-374mm)

### Mounting Surfaces

Wood stud, concrete, cinder block and metal stud  
(Metal stud accessory required)

### Ship Weight

8.5lb (3.8kg)

## CERTIFICATIONS



## ACCESSORIES



**ACC919:**  
Security Fasteners ..... pg# 199



**WSP700:**  
Metal Stud Wall Plate  
for 16" Center Metal Studs ... pg# 195



**WSP701:**  
Metal Stud Wall Plate for 20"  
and 24" Center Metal Studs .. pg# 195

To verify mount compatibility with any flat panel display or projector model use MountFinder™ at [www.peerless-av.com](http://www.peerless-av.com)



CALL: 630-375-5100  
800-865-2112



FAX: 630-820-8537  
800-359-6500



E-MAIL:  
[info@peerless-av.com](mailto:info@peerless-av.com)



ONLINE:  
[www.peerless-av.com](http://www.peerless-av.com)

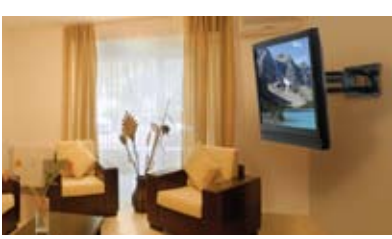

# Articulating Wall Arm

For 37" to 60" Flat Panel Displays

## MODELS

### Universal Models:

Includes standard hardware (hex or Phillips) for attaching display to mount

**PA760**      Gloss black

## DISPLAY ADAPTER

### Mounting Pattern

Universal Models: 730 x 433mm  
(28.75"W x 17.03"H)

### VESA® Pattern

Universal Models: Up to 600 x 400mm

## SPECIFICATIONS

### Distance from Wall

5.13"-16.12" (130-409mm)

### Tilt | Swivel

+15/-5° | ±45°

### Max Load

130lb (59kg)

### Product Dimensions (W x H x D)

30.75" x 18.00" x 5.13"-16.12"  
(781 x 457 x 130-409mm)

### Mounting Surfaces

Wood stud, concrete and cinder block

### Ship Weight

25lb (11kg)

1. Arm extends up to 16.12" (409mm) from the wall for virtually limitless viewing angles
2. Retracts to 5.13" (130mm) keeping the display close to the wall
3. One-Touch™ tilt mechanism offers up to +15/-5° of tilt angle adjustment
4. Up to 45° of pivot motion to position the display in the desired location
5. Integrated cable management keeps cables out of the way
6. Display is centered on wall plate

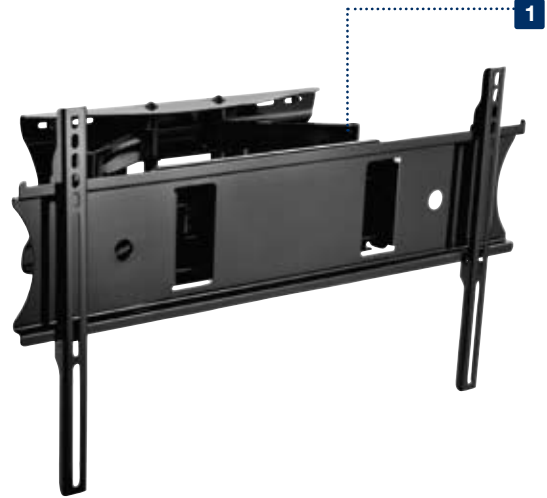

Patented

## CERTIFICATIONS



## TECHNICAL DRAWINGS

For expanded product information and technical data visit [www.peerless-av.com](http://www.peerless-av.com)

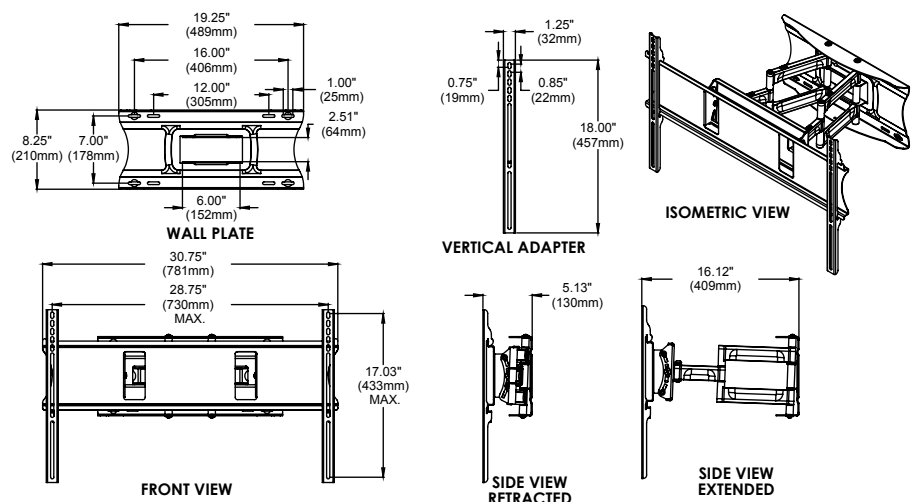

To verify mount compatibility with any flat panel display or projector model use MountFinder™ at [www.peerless-av.com](http://www.peerless-av.com)

CALL: 630-375-5100  
800-865-2112

FAX: 630-820-8537  
800-359-6500

E-MAIL: [info@peerless-av.com](mailto:info@peerless-av.com)

ONLINE: [www.peerless-av.com](http://www.peerless-av.com)

# Swivel and Tilt Wall Mount

For 32" to 71" Flat Panel Displays

1. 15° swivel from left to right
2. Offers 10° of forward tilt and 5° of backward tilt
3. Mount enables leveling adjustment of display to sit level at any angle; no tools required
4. Display mounts in landscape or portrait orientation
5. PS-1 arm holds display 8.75" (222mm)
6. PS-2 arm holds display 10.12" (257mm)



For expanded product information and technical data visit [www.peerless-av.com](http://www.peerless-av.com)

## TECHNICAL DRAWINGS

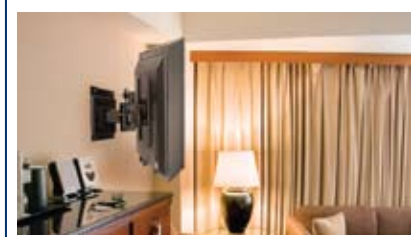
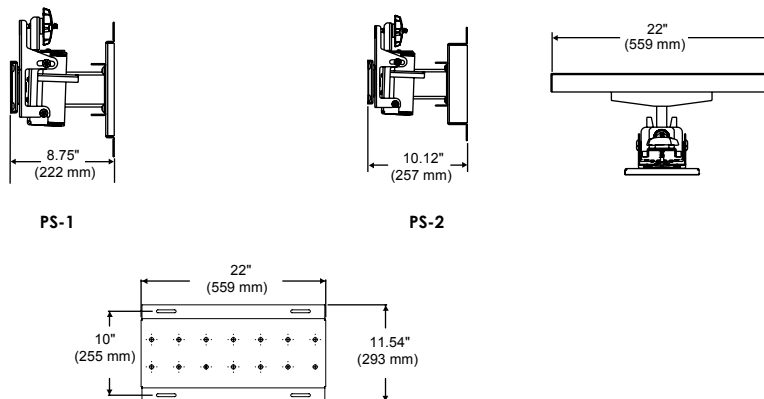

FLAT PANEL MOUNTS

## MODELS

### Dedicated Models:

Includes theft resistant hardware for attaching display to mount  
Display adapter purchased separately\*

- PS-1** Black for 32" to 50" displays  
**PS-2** Black for 42" to 71" displays

\*Dedicated adapter plates come in flat black and include security fasteners

## DISPLAY ADAPTER

**Dedicated Models:** Require display-specific PLP adapter to be purchased separately.

## SPECIFICATIONS

Distance from Wall	PS-1:	8.75" (222mm)
	PS-2:	10.12" (257mm)

Tilt   Swivel
+10°/-5°   ±15°

Max Load	PS-1:	150lb (68kg)
	PS-2:	225lb (102kg)

Product Dimensions (W x H x D)	PS-1:	22.00" x 12.08" x 8.75" (559 x 306 x 222mm)
	PS-2:	22.00" x 12.04" x 10.12" (559 x 305 x 257mm)

Mounting Surfaces
Wood stud, concrete and cinder block

Ship Weight	PS-1:	24lb (11kg)
	PS-2:	26.5lb (12kg)

## CERTIFICATIONS



To verify mount compatibility with any flat panel display or projector model use MountFinder™ at [www.peerless-av.com](http://www.peerless-av.com)



CALL: 630-375-5100  
800-865-2112



FAX: 630-820-8537  
800-359-6500



E-MAIL: [info@peerless-av.com](mailto:info@peerless-av.com)



ONLINE: [www.peerless-av.com](http://www.peerless-av.com)



# Universal Tablet Cradle

## MODELS

### Universal Models:

Includes standard hardware (hex or Phillips) for attaching tablet to mount

- PTM200\*** Black
- PTM200-S\*** Silver

\* Designed for use with tablets that are less than 0.75" (19mm) deep

## DISPLAY ADAPTER

### VESA® Pattern

Universal Models: 75 x 75mm

## SPECIFICATIONS

### Max Load

5lb (2.27kg)

### Product Dimensions (W x H x D)

6.92"-11.42" x 4.48"-8.47" x 1.65"  
(176-290 x 114-215 x 42mm)

### Mounting Surfaces

Any 75 x 75mm VESA® mount

## ACCESSORIES



**ACC954:**  
Theft Resistant Security Kit .... pg# 199



**SF630 models:**  
SmartMount® Universal Flat Wall Mount ..... pg# 33



**ST630 models:**  
SmartMount® Universal Tilt Wall Mount..... pg# 40



**SP730P models:**  
SmartMount® Universal Pivot Wall Mount..... pg# 48



**SA730P models:**  
SmartMount® Universal Articulating Wall Arm..... pg# 51



**LCH/LCT/LCV/LCW/LCZ models:**  
Desktop Mounts..... pg# 100-110

1. Adjustable height and width, providing a universal fit for most tablets
2. Easily attaches to any 75 x 75mm VESA® mount
3. Stylish cover for improved aesthetics

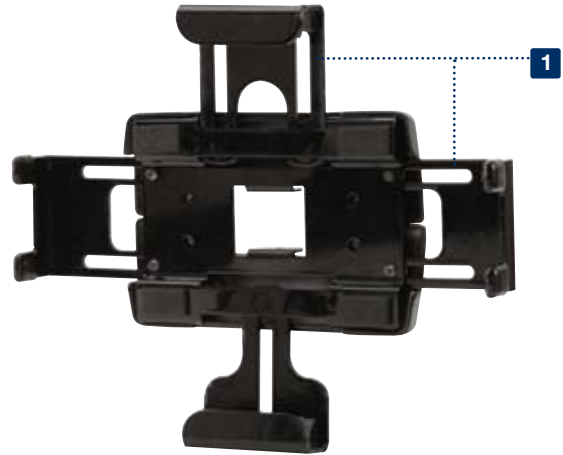

Note: Tablet and mount not included

Patented

## TECHNICAL DRAWINGS

For expanded product information and technical data visit [www.peerless-av.com](http://www.peerless-av.com)

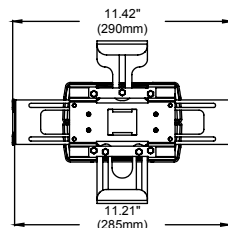

FRONT VIEW EXTENDED

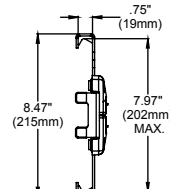

SIDE VIEW EXTENDED

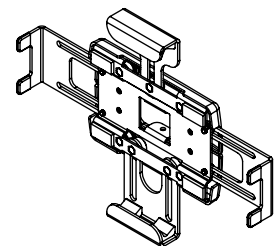

ISOMETRIC VIEW

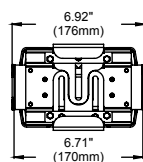

FRONT VIEW RETRACTED

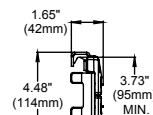

SIDE VIEW RETRACTED

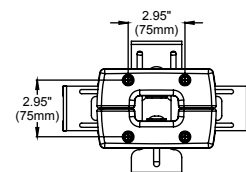

REAR MOUNTING HOLES

To verify mount compatibility with any flat panel display or projector model use MountFinder™ at [www.peerless-av.com](http://www.peerless-av.com)



CALL: 630-375-5100  
800-865-2112



FAX: 630-820-8537  
800-359-6500



E-MAIL:  
[info@peerless-av.com](mailto:info@peerless-av.com)



ONLINE:  
[www.peerless-av.com](http://www.peerless-av.com)



# Universal Desktop Tablet Mount



FLAT PANEL MOUNTS

1. Adjustable height and width, providing a universal fit for most tablets
2. Stylish cover for improved aesthetics
3.  $\pm 30^\circ$  of One-Touch™ tilt and swivel
4.  $360^\circ$  of roll for versatile placement options
5. Option to place on desk or secure down with theft resistant security screws
6. Two color options available for coordinating with tablet aesthetics



Note: Tablet not included

Patented

For expanded product information and technical data visit [www.peerless-av.com](http://www.peerless-av.com)

## TECHNICAL DRAWINGS

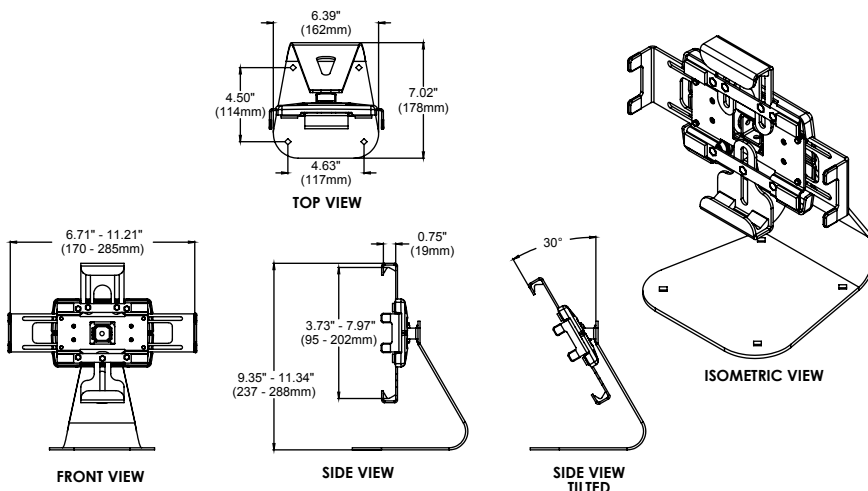

## MODELS

### Universal Models:

Includes theft resistant hardware for attaching tablet to mount

**PTM400S\*** Black  
**PTM400S-W\*** White

Includes standard hardware (hex or Phillips) for attaching tablet to mount

**PTM400\*** Black  
**PTM400-W\*** White

\* Designed for use with tablets that are less than 0.75" (19mm) deep

## SPECIFICATIONS

	<b>Tilt   Swivel   Roll</b>
	$\pm 30^\circ$   $\pm 30^\circ$   $\pm 360^\circ$
	<b>Max Load</b>
	5lb (2.27kg)
	<b>Landscape to Portrait</b>
	Tablet can be rotated from landscape to portrait without removing the tablet
<b>Product Dimensions</b>	(W x H x D)
	6.71"-11.21" x 9.35"-11.34" x 7.02" (170-285 x 237-288 x 178mm)
<b>Mounting Surfaces</b>	Desktop

## ACCESSORIES



**ACC954:**  
Theft Resistant Security Kit .... pg# 199

To verify mount compatibility with any flat panel display or projector model use MountFinder™ at [www.peerless-av.com](http://www.peerless-av.com)



CALL: 630-375-5100  
800-865-2112



FAX: 630-820-8537  
800-359-6500



E-MAIL:  
[info@peerless-av.com](mailto:info@peerless-av.com)



ONLINE:  
[www.peerless-av.com](http://www.peerless-av.com)



# ONEMount® Modular Wall Mount

For 23" to 84" Flat Panel Displays

## MODELS

### Universal Models:

Includes theft resistant and standard hardware (hex or Phillips) for securing display to mount

**ONE-TP** Black

## DISPLAY ADAPTER

### Mounting Pattern

Universal Models	
1-plate Configuration:	445 x 673mm (17.52"W x up to 26.48"H)
2-plate Configuration:	747 x 673mm (29.4"W x up to 26.48"H)
3-plate Configuration:	1050 x 673mm (41.32"W x up to 26.48"H)

## SPECIFICATIONS

### Distance from Wall

3.26" (83mm)

### Tilt

+15/-5°

### Max Load

250lb (113kg)

### Product Dimensions (W x H x D)

1-plate Configuration:	19.25" x 13.75" x 3.26" (489 x 349 x 83mm)
2-plate Configuration:	31.13" x 27.32" x 3.26" (791 x 694 x 83mm)
3-plate Configuration:	43.00" x 27.32" x 3.26" (1092 x 694 x 83mm)

### Mounting Surfaces

Wood stud, concrete, cinder block and metal stud (Metal stud accessory required)

### Ship Weight

18.7lb (8.5kg)

## CERTIFICATIONS



## ACCESSORIES



**ACC415:** (for 1 and 2-plate configurations)  
4-pack Metal Stud Fastener Kit ..... pg# 196



**ACC615:** (for 3-plate configuration)  
6-pack Metal Stud Fastener Kit ..... pg# 196



**ACC937:**  
M10 Mounting Hole Adapters ..... pg# 195

1. Modular design expands mount to accommodate 23" to 84" displays
2. Horizontal display adjustment up to 8" (203mm)
3. Tilt allows adjustment of +15/-5° without use of tools
4. Included IncreLoK™ feature offers fixed tilt lock in 5° increments when used
5. Easy-Glide™ bracket design ensures display is securely attached to wall plate
6. Fits displays with mounting hole patterns up to 1050 x 673mm (41.32"W x 26.48"H)
7. Portrait orientation for up to 50" displays with maximum mounting hole patterns of 445 x 673mm (17.52"W x 26.48"H)
8. Wall plate knockouts provide wall access for improved power and cable management

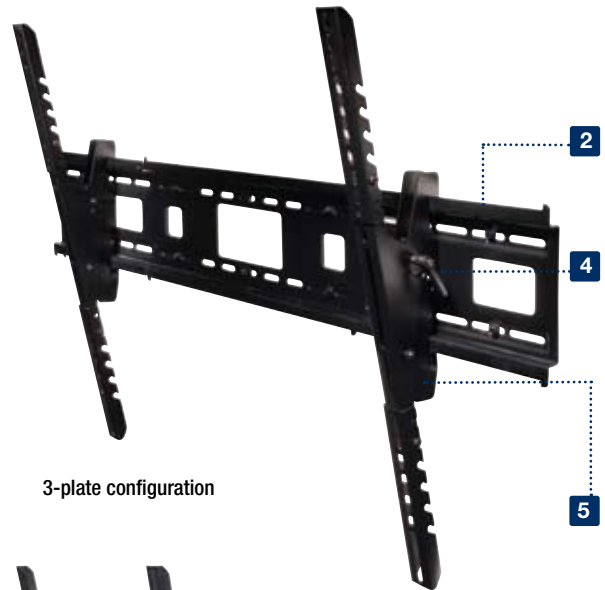

3-plate configuration



2-plate configuration



1-plate configuration

Patented

## TECHNICAL DRAWINGS

For expanded product information and technical data visit [www.peerless-av.com](http://www.peerless-av.com)

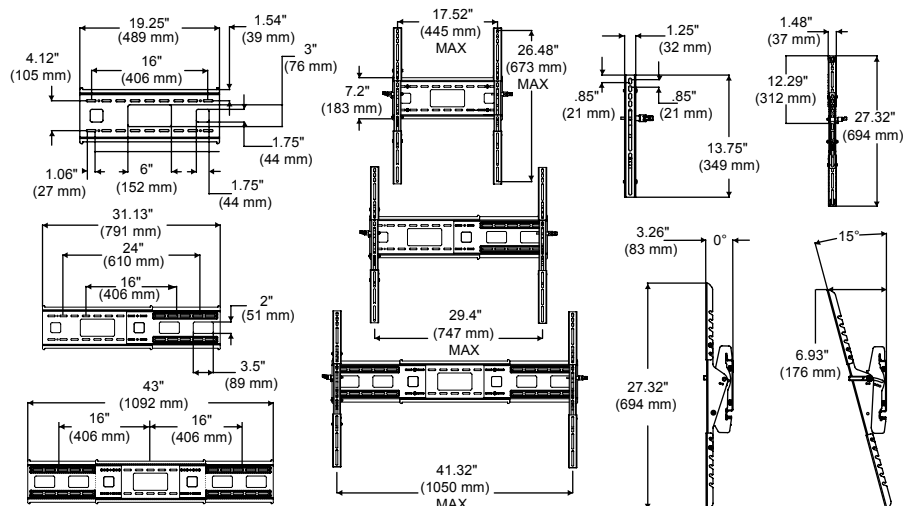

To verify mount compatibility with any flat panel display or projector model use MountFinder™ at [www.peerless-av.com](http://www.peerless-av.com)



CALL: 630-375-5100  
800-865-2112



FAX: 630-820-8537  
800-359-6500



E-MAIL: [info@peerless-av.com](mailto:info@peerless-av.com)



ONLINE: [www.peerless-av.com](http://www.peerless-av.com)

# PLA Series Articulating Wall Arm

## For 32" to 65" Flat Panel Displays



FLAT PANEL MOUNTS

1. Arm extends up to 30.52" (775mm) from wall
2. Three adjustable pivot points with up to 180° swivel for versatile display positioning
3. +10/-5° of tilt
4. ±7° of roll for post installation display leveling
5. Universal models adapt to displays with mounting hole patterns up to 731 x 433mm (28.76"W x 17.05"H)
6. Includes mesh cord sheath and cable ties to neatly manage cables
7. Five horizontal arm positions at 2.6" (66mm) centers for flexible lateral display placement

Universal Models



Dedicated Models

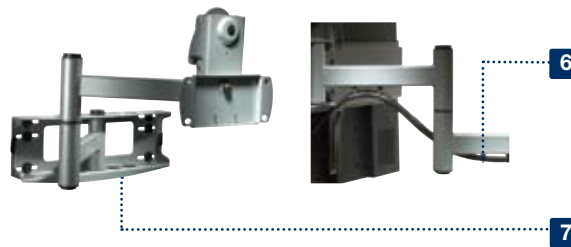

For expanded product information and technical data visit [www.peerless-av.com](http://www.peerless-av.com)

### TECHNICAL DRAWINGS

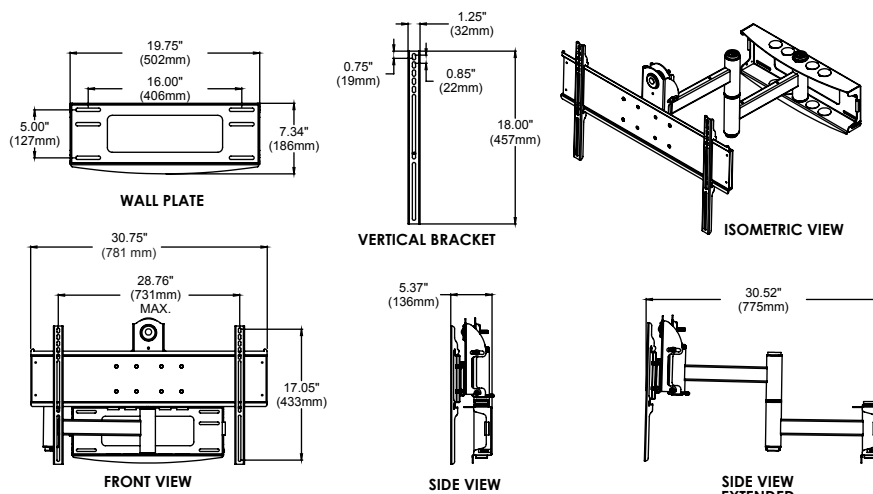

### MODELS

#### Universal Models:

Includes standard hardware (hex or Phillips) for attaching display to mount

**PLA50-UNL** Black  
**PLA50-UNL-S** Silver

Includes standard hardware (hex or Phillips) for attaching display to mount

**PLA50-UNLP** Black  
**PLA50-UNLP-S** Silver  
**PLA50-UNLP-GB** High gloss black  
**PLA50-UNLP-GS** High gloss silver

#### Dedicated Models:

Includes theft resistant hardware for attaching display to mount  
 Display adapter purchased separately\*

**PLA50** Black  
**PLA50-S** Silver

\* Dedicated adapter plates come in flat black and include security fasteners

### DISPLAY ADAPTER



#### Mounting Pattern

**Universal Models:** 731 x 433mm  
 (28.76"W x 17.05"H)

**Dedicated Models:** Requires display-specific adapter to be purchased separately.

### SPECIFICATIONS



#### Distance from Wall

**Universal Models:** 5.37"-30.52" (136-775mm)

**Dedicated Models:** 4.50"-29.3" (114-744mm)



#### Tilt | Swivel | Roll

+10/-5° | ±90° | ±7°



#### Max Load

150lb (68kg)

#### Product Dimensions (W x H x D)

**Universal Models:** 30.75" x 19.10" x 5.37"-30.52"  
 (781 x 486 x 136-775mm)

**Dedicated Models:** 19.75" x 18.70" x 4.50"-29.30"  
 (501 x 474 x 114-744mm)

#### Mounting Surfaces

Wood stud, concrete and metal stud  
 (Metal stud accessory required)

#### Ship Weight

**Universal Models:** 43lb (19.5kg)

**Dedicated Models:** 28.5lb (12.9kg)

### CERTIFICATIONS



### ACCESSORIES



**WSP716:** (Triple stud on 16" centers)  
 Metal Stud Wall Plate ..... pg# 195



**WSP724:** (Triple stud on 16"-24" centers)  
 Metal Stud Wall Plate ..... pg# 195

To verify mount compatibility with any flat panel display or projector model use MountFinder™ at [www.peerless-av.com](http://www.peerless-av.com)

CALL: 630-375-5100  
 800-865-2112

FAX: 630-820-8537  
 800-359-6500

E-MAIL: info@peerless-av.com

ONLINE: [www.peerless-av.com](http://www.peerless-av.com)



# PLA Series Articulating Wall Arm

For 37" to 65" Flat Panel Displays

## MODELS

### Universal Models:

Includes standard hardware (hex or Phillips) for attaching display to mount

- PLA60-UNL** Black
- PLA60-UNL-S** Silver

Includes standard hardware (hex or Phillips) for attaching display to mount

- PLA60-UNLP** Black
- PLA60-UNLP-S** Silver
- PLA60-UNLP-GB** High gloss black
- PLA60-UNLP-GS** High gloss silver

### Dedicated Models:

Includes theft resistant hardware for attaching display to mount  
Display adapter purchased separately\*

- PLA60** Black
- PLA60-S** Silver

\* Dedicated adapter plates come in flat black and include security fasteners

## DISPLAY ADAPTER



### Mounting Pattern

**Universal Models:** 731 x 433mm  
(28.76"W x 17.04"H)

**Dedicated Models:** Requires display-specific adapter to be purchased separately.

## SPECIFICATIONS



### Distance from Wall

**Universal Models:** 5.37"-32.37" (136-822mm)  
**Dedicated Models:** 4.50"-31.20" (114-792mm)



### Tilt | Swivel | Roll

+10/-5° | ±90° | ±7°



### Max Load

175lb (79kg)

### Product Dimensions (W x H x D)

**Universal Models:** 30.75" x 19.10" x 5.37"-32.37"  
(781 x 486 x 136-822mm)

**Dedicated Models:** 19.75" x 19.12" x 4.50"-31.20"  
(502 x 486 x 114-792mm)

### Mounting Surfaces

Wood stud, concrete and metal stud  
(Metal stud accessory required)

### Ship Weight

**Universal Models:** 48.5lb (21.9kg)  
**Dedicated Models:** 34.1lb (15.4kg)

## CERTIFICATIONS



## ACCESSORIES



**WSP716:** (Triple stud on 16" centers)  
Metal Stud Wall Plate ..... pg# 195



**WSP724:** (Triple stud on 16"-24" centers)  
Metal Stud Wall Plate ..... pg# 195

1. Arm extends up to 32.37" (822mm) from wall
2. Three pivot points with up to 180° swivel for versatile display positioning
3. +10/-5° of tilt
4. ±7° of roll for post installation display leveling
5. Universal models adapt to displays with mounting hole patterns up to 731 x 433mm (28.76"W x 17.04"H)
6. Includes mesh cord sheath and cable ties to neatly manage cables
7. Five horizontal arm positions at 2.6" (66mm) centers for flexible lateral display placement

Universal Models

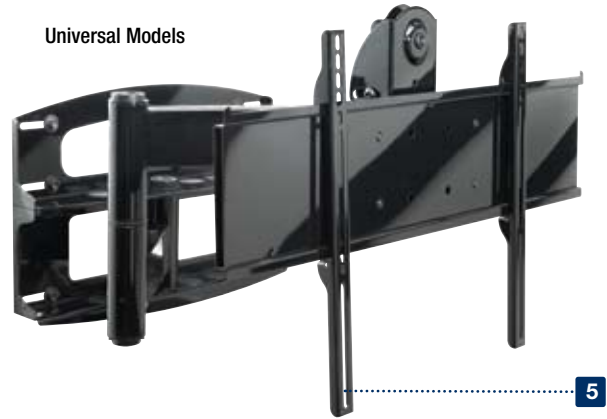

Dedicated Models

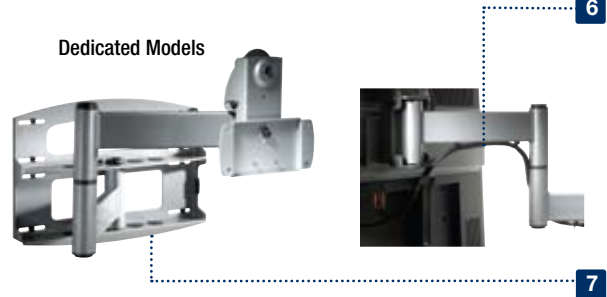

## TECHNICAL DRAWINGS

For expanded product information and technical data visit [www.peerless-av.com](http://www.peerless-av.com)

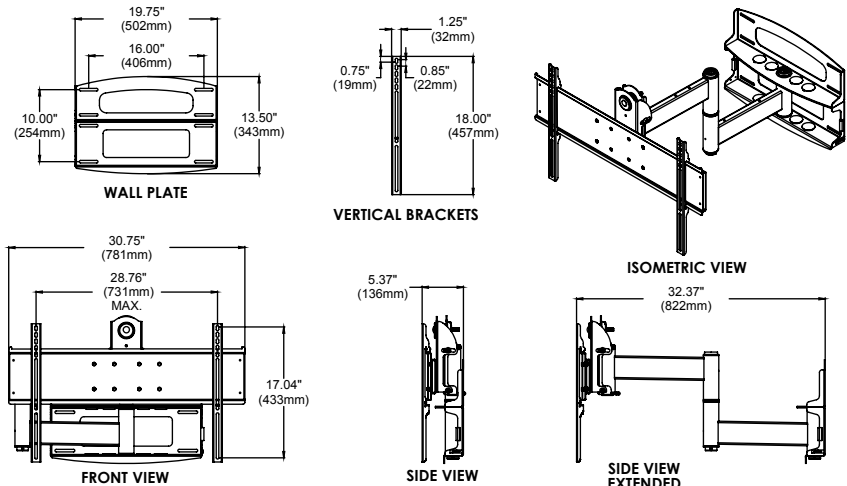

To verify mount compatibility with any flat panel display or projector model use MountFinder™ at [www.peerless-av.com](http://www.peerless-av.com)



**CALL:** 630-375-5100  
800-865-2112



**FAX:** 630-820-8537  
800-359-6500



**E-MAIL:**  
[info@peerless-av.com](mailto:info@peerless-av.com)



**ONLINE:**  
[www.peerless-av.com](http://www.peerless-av.com)

# PLA Series Articulating Wall Arm with Vertical Adjustment

## For 37" to 65" Flat Panel Displays



FLAT PANEL MOUNTS

1. Arm extends up to 32.27" (822mm) from wall
2. Three pivot points with up to 180° swivel for versatile display positioning
3. +10/-5° of tilt
4. ±7° of roll for post installation display leveling
5. ±1" (25.4mm) vertical adjustment located within reach behind display
6. Universal models adapt to displays with mounting hole patterns up to 731 x 433mm (28.76"W x 17.04"H)
7. Includes mesh cord sheath and cable ties to neatly manage cables
8. Five horizontal arm positions at 2.6" (66mm) centers for flexible lateral display placement

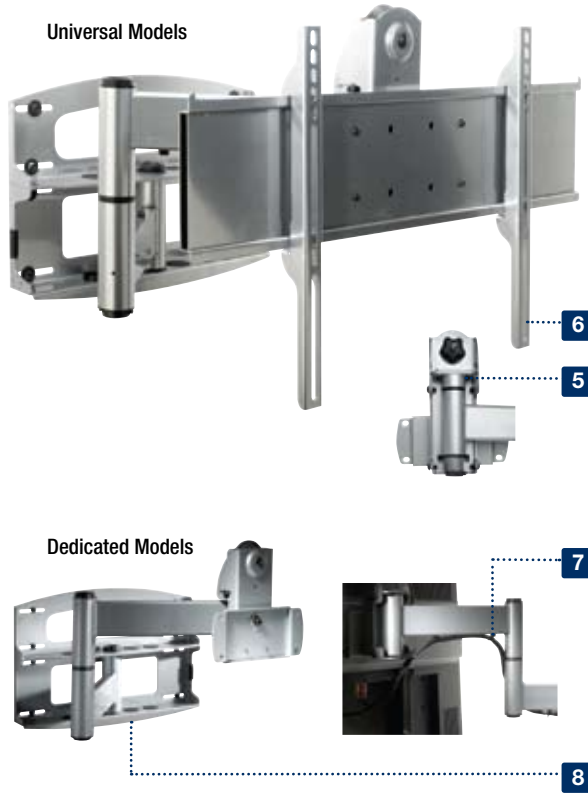

Patented

For expanded product information and technical data visit [www.peerless-av.com](http://www.peerless-av.com)

### TECHNICAL DRAWINGS

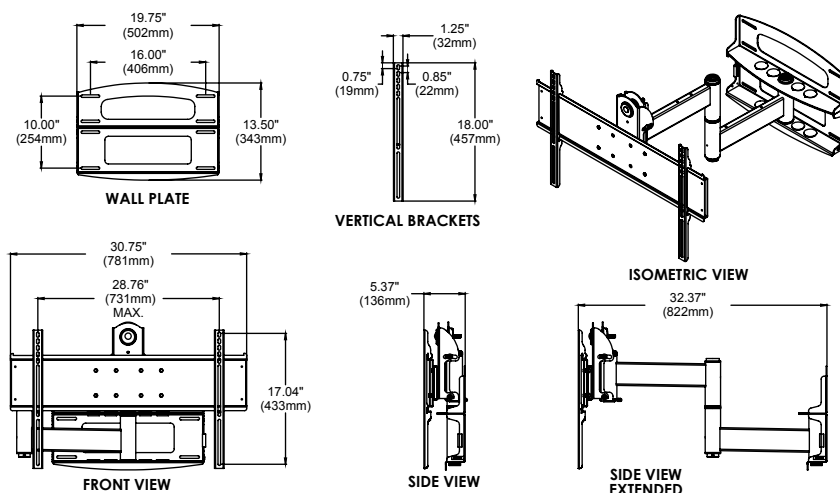

### MODELS

#### Universal Models:

Includes standard hardware (hex or Phillips) for attaching display to mount

- PLAV60-UNL** Black
- PLAV60-UNL-S** Silver

Includes standard hardware (hex or Phillips) for attaching display to mount

- PLAV60-UNLP** Black
- PLAV60-UNLP-S** Silver
- PLAV60-UNLP-GB** High gloss black
- PLAV60-UNLP-GS** High gloss silver

#### Dedicated Models:

Includes theft resistant hardware for attaching display to mount  
Display adapter purchased separately\*

- PLAV60** Black
- PLAV60-S** Silver

\* Dedicated adapter plates come in flat black and include security fasteners

### DISPLAY ADAPTER



#### Mounting Pattern

**Universal Models:** 731 x 433mm  
(28.76"W x 17.04"H)

**Dedicated Models:** Requires display-specific adapter to be purchased separately.

### SPECIFICATIONS



#### Distance from Wall

**Universal Models:** 5.37"-32.37" (136-822mm)

**Dedicated Models:** 4.50"-31.20" (114-792mm)



#### Tilt | Swivel | Roll

+10/-5° | ±90° | ±7°



#### Max Load

175lb (79kg)

#### Product Dimensions (W x H x D)

**Universal Models:** 30.75" x 21.67" x 5.37"-32.37"  
(781 x 550 x 136-822mm)

**Dedicated Models:** 19.75" x 21.67" x 4.50"-31.20"  
(502 x 550 x 114-792mm)

#### Mounting Surfaces

Wood stud, concrete and metal stud  
(Metal stud accessory required)

#### Ship Weight

**Universal Models:** 50.6lb (22.9kg)

**Dedicated Models:** 36.2lb (16.4kg)

### CERTIFICATIONS



### ACCESSORIES



**WSP716:** (Triple stud on 16" centers)  
Metal Stud Wall Plate ..... pg# 195



**WSP724:** (Triple stud on 16"-24" centers)  
Metal Stud Wall Plate ..... pg# 195

To verify mount compatibility with any flat panel display or projector model use MountFinder™ at [www.peerless-av.com](http://www.peerless-av.com)

CALL: 630-375-5100  
800-865-2112

FAX: 630-820-8537  
800-359-6500

E-MAIL: [info@peerless-av.com](mailto:info@peerless-av.com)

ONLINE: [www.peerless-av.com](http://www.peerless-av.com)



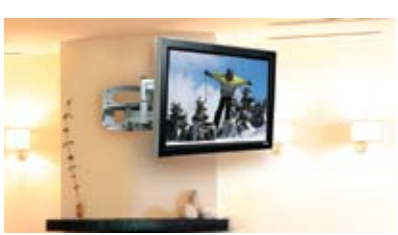

# PLA Series Articulating Dual Wall Arm with Vertical Adjustment

For 42" to 71" Flat Panel Displays

## MODELS

**Universal Models:** 42" to 65" displays

Includes standard hardware (hex or Phillips) for attaching display to mount

**PLAV70-UNL** Black  
**PLAV70-UNL-S** Silver

Includes standard hardware (hex or Phillips) for attaching display to mount

**PLAV70-UNLP** Black  
**PLAV70-UNLP-S** Silver  
**PLAV70-UNLP-GB** High gloss black  
**PLAV70-UNLP-GS** High gloss silver

**Dedicated Models:** 42" to 71" displays

Includes theft resistant hardware for attaching display to mount  
Display adapter purchased separately\*

**PLAV70** Black  
**PLAV70-S** Silver

\* Dedicated adapter plates come in flat black and include security fasteners

## DISPLAY ADAPTER



### Mounting Pattern

**Universal Models:** 731 x 433mm  
(28.76"W x 17.05"H)

**Dedicated Models:** Requires display-specific adapter to be purchased separately.

## SPECIFICATIONS



### Distance from Wall

**Universal Models:** 5.52"-32.52" (140-826mm)  
**Dedicated Models:** 4.50"-29.30" (114-744mm)



### Tilt | Swivel | Roll

+10/-5° | ±45° | ±7°



### Max Load

200lb (90kg)

### Product Dimensions (W x H x D)

**Universal Models:** 33.50" x 21.67" x 5.52"-32.52"  
(851 x 550 x 140-826mm)

**Dedicated Models:** 19.75" x 21.67" x 4.50"-29.30"  
(502 x 550 x 114-744mm)

### Mounting Surfaces

Wood stud, concrete and metal stud  
(Metal stud accessory required)

### Ship Weight

**Universal Models:** 72.4lb (32.9kg)  
**Dedicated Models:** 58.5lb (26.5kg)

## CERTIFICATIONS



## ACCESSORIES



**WSP716:** (Triple stud on 16" centers)  
Metal Stud Wall Plate ..... pg# 195



**WSP724:** (Triple stud on 16"-24" centers)  
Metal Stud Wall Plate ..... pg# 195

1. Arm extends up to 32.52" (826mm) from wall
2. Up to 180° swivel
3. +10/-5° of tilt
4. ±7° of roll for post installation display leveling
5. ±1" (25mm) vertical adjustment located within reach behind display
6. Universal models accommodate 42" to 65" displays with mounting hole patterns up to 731 x 433mm (28.76"W x 17.05"H)
7. Includes mesh cord sheath and cable ties to neatly manage cables
8. Three horizontal arm positions at 2.6" (66mm) centers for flexible lateral display placement



Patented

## TECHNICAL DRAWINGS

For expanded product information and technical data visit [www.peerless-av.com](http://www.peerless-av.com)

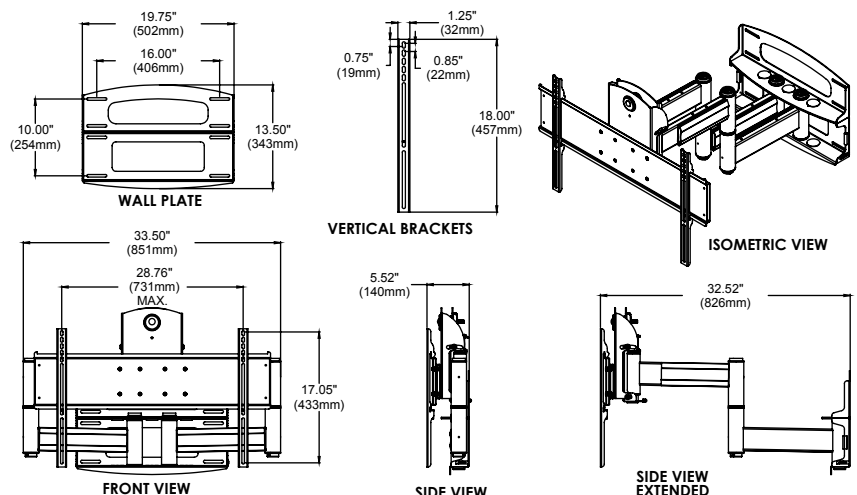

CALL: 630-375-5100  
800-865-2112



FAX: 630-820-8537  
800-359-6500



E-MAIL: [info@peerless-av.com](mailto:info@peerless-av.com)



ONLINE: [www.peerless-av.com](http://www.peerless-av.com)

# In-Wall Mount

For 22" to 40" Flat Panel Displays

1. Installs between 16" (406mm) wood stud centers
2. Stud-locating tabs adjust 1/4" (6mm) left or right to accommodate stud spacing
3. Includes articulating mount for up to 40" displays
4. Removable outlet receptacle and cable management access plates make installation easy
5. Height adjustment points in box to set display in desired vertical position
6. VESA® 75, 100, 200 x 100 and 200 x 200mm compliant
7. Can be inverted to position display to the right or the left
8. Compatible with flat panels that use M8 screws



Patented

For expanded product information and technical data visit [www.peerless-av.com](http://www.peerless-av.com)

## TECHNICAL DRAWINGS

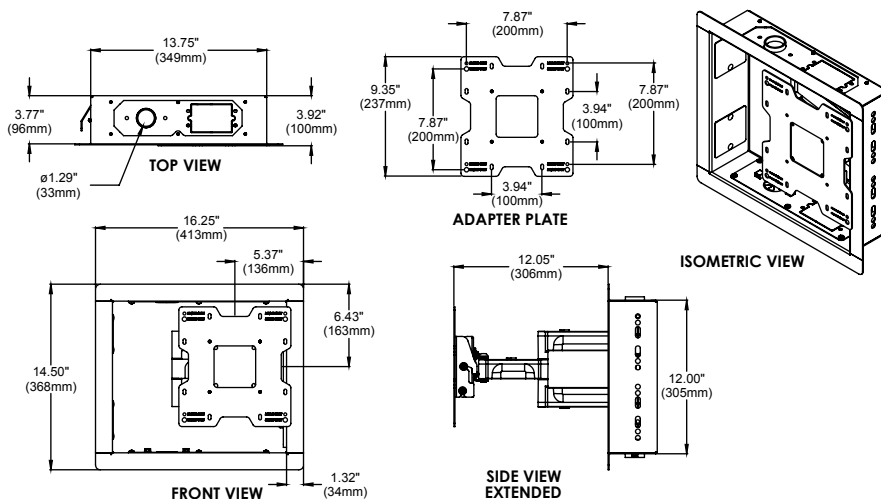

To verify mount compatibility with any flat panel display or projector model use MountFinder™ at [www.peerless-av.com](http://www.peerless-av.com)



CALL: 630-375-5100  
800-865-2112



FAX: 630-820-8537  
800-359-6500



E-MAIL: [info@peerless-av.com](mailto:info@peerless-av.com)



ONLINE: [www.peerless-av.com](http://www.peerless-av.com)



FLAT PANEL MOUNTS

## MODELS

### Universal Models:

Includes standard hardware (hex or Phillips) for attaching display to mount

**IM740P**  
**IM740P-S**

High gloss black  
High gloss silver

## DISPLAY ADAPTER



### VESA® Pattern

Universal Models: 75, 100, 200 x 100 and 200 x 200mm

## SPECIFICATIONS



### Distance from Wall

0.08"-12.05" (2-306mm)



### Tilt | Swivel | Roll

+15/-5° | ±45° | ±5°



### Max Load

80lb (36kg)

### Product Dimensions

(W x H x D)

16.25" x 14.50" x 3.92"-15.97"  
(413 x 368 x 100-406mm)

### Mounting Surfaces

Wood stud

### Ship Weight

22.63lb (57.4kg)

## CERTIFICATIONS





# In-Wall Mount

## For 32" to 71" Flat Panel Displays

### MODELS

**Universal Models:** 32" to 65" displays

Includes standard hardware (hex or Phillips) for attaching display to mount

**IM760PU** High gloss black  
**IM760PU-S** High gloss silver

**Dedicated Models:** 32" to 71" displays

Includes standard hardware (hex or Phillips) for attaching display to mount  
Display Adapter Purchased Separately for Non-VESA® Displays\*

**IM760P** High gloss black  
**IM760P-S** High gloss silver

\*Dedicated adapter plates come in flat black and include security fasteners

### DISPLAY ADAPTER



#### Mounting Pattern

**Universal Models:** 730 x 433mm  
(28.75"W x 17.05"H)



#### VESA® Pattern

**Dedicated Models:** 100, 200 x 100  
and 200 x 200mm  
Non-VESA® compatible displays  
require display-specific adapter to  
be purchased separately.

### SPECIFICATIONS



#### Distance from Wall

**Universal Models:** 2.14"-19.88" (54-505mm)  
**Dedicated Models:** 0.42"-18.09" (11-459mm)



#### Tilt | Swivel | Roll

+10/-5° | ±45° | ±7°



#### Max Load

200lb (90kg)

#### Product Dimensions (W x H x D)

**Universal Models:** 30.75" x 21.86" x 4.34"-23.80"  
(780 x 555 x 110-604mm)  
**Dedicated Models:** 19.46" x 21.86" x 4.38"-22.56"  
(494 x 555 x 111-573mm)

#### Mounting Surfaces

Wood stud and metal stud  
(Metal stud accessory required)

#### Ship Weight

**Universal Models:** 42.6lb (19.32kg)  
**Dedicated Models:** 58.49lb (26.53kg)

### CERTIFICATIONS



### ACCESSORIES



**ACC615:** (Supports up to 125lb (62kg) displays)  
6-pack Metal Stud  
Fastener Kit .....pg# 196



**ACC925:**  
Security Fasteners .....pg# 199

1. Installs between 1 1/2" (406mm) wood stud centers
2. Stud-locating tabs adjust 1/4" (6mm) left or right to accommodate stud spacing
3. Removable outlet receptacle and cable management access plates make installation easy
4. Can be inverted to position display to the right or the left
5. IM760P models are VESA® 100, 200 x 100 and 200 x 200mm compliant

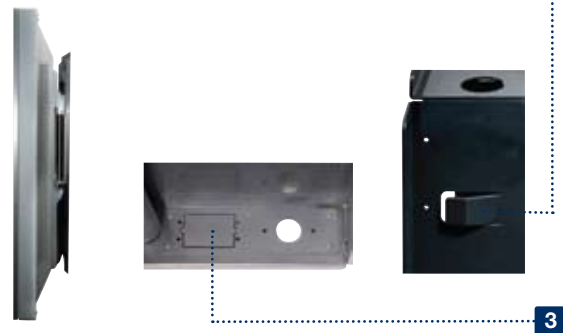

### TECHNICAL DRAWINGS

For expanded product information and technical data visit [www.peerless-av.com](http://www.peerless-av.com)

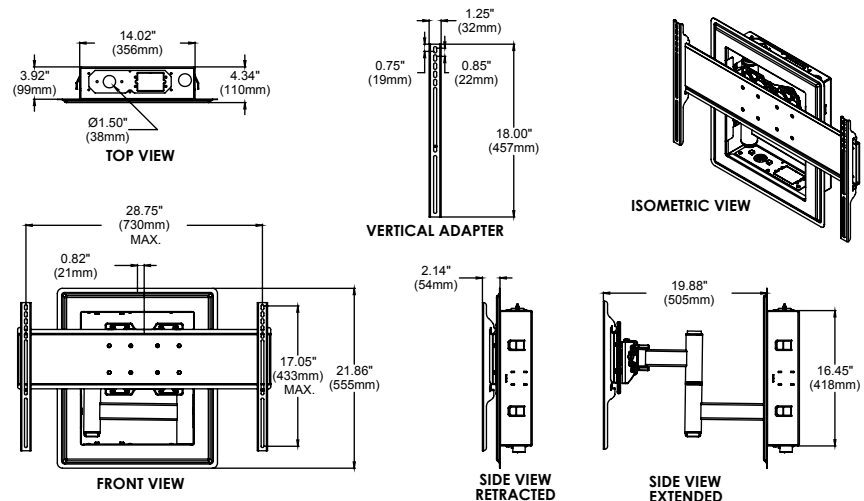

To verify mount compatibility with any flat panel display or projector model use MountFinder™ at [www.peerless-av.com](http://www.peerless-av.com)



CALL: 630-375-5100  
800-865-2112



FAX: 630-820-8537  
800-359-6500



E-MAIL:  
[info@peerless-av.com](mailto:info@peerless-av.com)



ONLINE:  
[www.peerless-av.com](http://www.peerless-av.com)

# In-Wall Box

For up to 40" Flat Panel Displays

- Compatible with PA730, PA740, PP730 & PP740, sold separately
- Installs between 16" (406mm) wood stud centers
- Stud-locating tabs adjust 1/4" (6mm) left or right to accommodate stud spacing
- Removable outlet receptacle and cable management access plates make installation easy
- Three height adjustment points in box set display in desired vertical position
- Can be inverted to position display to the right or the left
- Display mount required

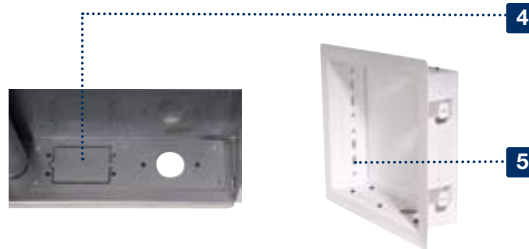

For expanded product information and technical data visit [www.peerless-av.com](http://www.peerless-av.com)

## TECHNICAL DRAWINGS

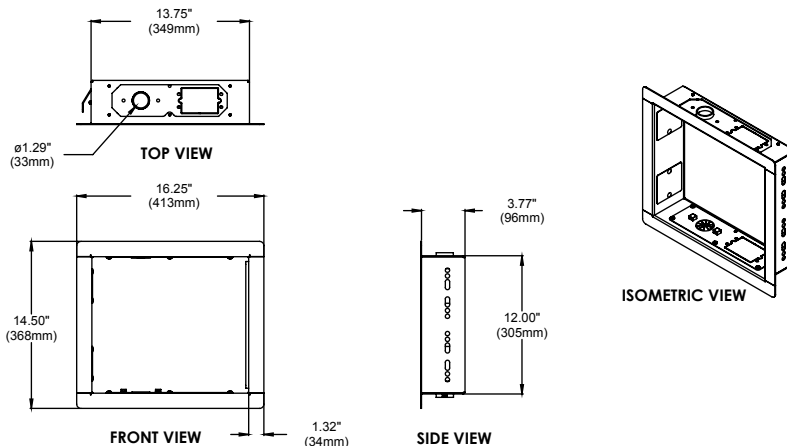

FLAT PANEL MOUNTS

## MODELS

### Universal Models:

Includes standard hardware (hex or Phillips) for attaching display to mount

<b>IB40</b>	High gloss black
<b>IB40-S</b>	High gloss silver
<b>IB40-W</b>	White

## SPECIFICATIONS

	<b>Distance from Wall</b>	0.08" (2mm)
	<b>Max Load</b>	80lb (36kg)
	<b>Product Dimensions (W x H x D)</b>	16.25" x 14.50" x 3.77" (413 x 368 x 96mm)
	<b>Mounting Surfaces</b>	Wood stud
	<b>Ship Weight</b>	14.23lb (6.45kg)

## CERTIFICATIONS



## ACCESSORIES

- PP730:** Pivot Wall Mount for 10" to 24" Flat Panel Displays ..... pg# 70
- PP740:** Pivot Wall Mount for 22" to 40" Flat Panel Displays ..... pg# 71
- PA730:** Articulating Wall Arm for 10" to 24" Flat Panel Displays ..... pg# 72
- PA740:** Articulating Wall Arm for 22" to 40" Flat Panel Displays ..... pg# 74

To verify mount compatibility with any flat panel display or projector model use MountFinder™ at [www.peerless-av.com](http://www.peerless-av.com)



# Rotational Mount Interface

For up to 71" Flat Panel Displays

## MODELS

### Dedicated Model:

Requires Peerless-AV wall mount, ceiling mount, cart or stand, sold separately.  
Display Adapter Purchased Separately\*

**RMI1** Black

\* Dedicated adapter plates come in flat black and include security fasteners

## DISPLAY ADAPTER

**Dedicated Model:** Requires display-specific PLP adapter to be purchased separately.

## SPECIFICATIONS

**Distance from Wall**

0.94" (24mm)

**Roll**

360°

**Max Load**

175lb (79kg)

**Landscape to Portrait**

Display can be rotated from landscape to portrait without removing the display

**Product Dimensions (W x H x D)**

12.94" x 7.38" x 0.94"  
(329 x 187 x 24mm)

**Mounting Surfaces**

To be used with Peerless-AV SF16D/24D and ST16D/24D wall mounts, ceiling mounts, carts or stands.  
(Sold Separately)

**Ship Weight**

5.5lb (2.5kg)

## CERTIFICATIONS



## ACCESSORIES



**ACC170:**  
SR Cart and SS Stand Adapter Plate..... pg# 195

1. Allows display to be orientated from landscape to portrait without removing the display from the mount
2. Display can be rotated 360° without impediment
3. Display roll angle can be locked in 15° increments
4. Spring loaded handle makes adjusting the displays position simple

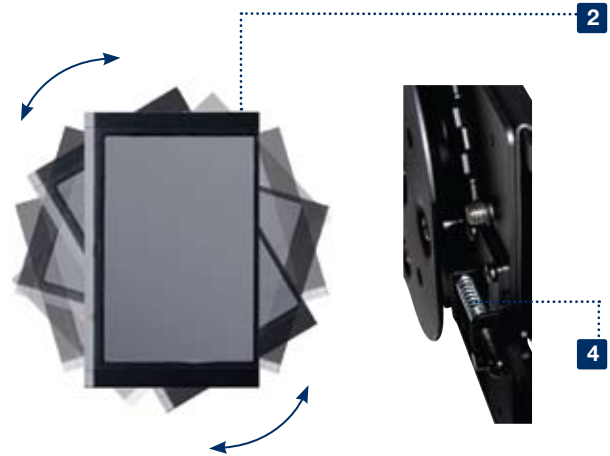

Patented

## TECHNICAL DRAWINGS

For expanded product information and technical data visit [www.peerless-av.com](http://www.peerless-av.com)

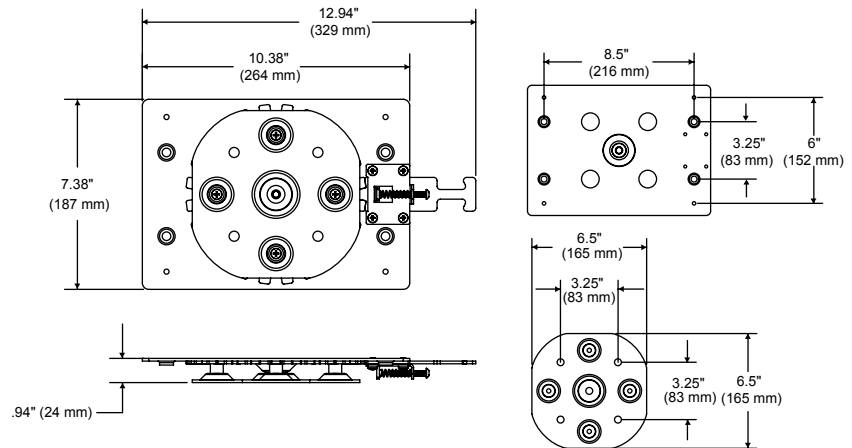

To verify mount compatibility with any flat panel display or projector model use MountFinder™ at [www.peerless-av.com](http://www.peerless-av.com)



CALL: 630-375-5100  
800-865-2112



FAX: 630-820-8537  
800-359-6500



E-MAIL: [info@peerless-av.com](mailto:info@peerless-av.com)



ONLINE: [www.peerless-av.com](http://www.peerless-av.com)



# Corner Mount

For 32" to 60" Flat Panel Displays



FLAT PANEL MOUNTS

1. Allows display to fit in corner where space is limited
2. Includes SmartMount® SP850-UNL Pull-Out Pivot Mount
3. Expandable arms accommodate multiple display sizes without having to adjust wall mount placement
4. SP850-UNL extends up to 10.75" (273mm), pull-out swivel with up to 90° rotation; 0°, 5° or 10° IncreLok™ tilt
5. Wall units accommodate speakers when used with smaller displays (wall unit maybe visible with some smaller displays)
6. Optional shelf available for AV components

Universal Models



For expanded product information and technical data visit [www.peerless-av.com](http://www.peerless-av.com)

## TECHNICAL DRAWINGS

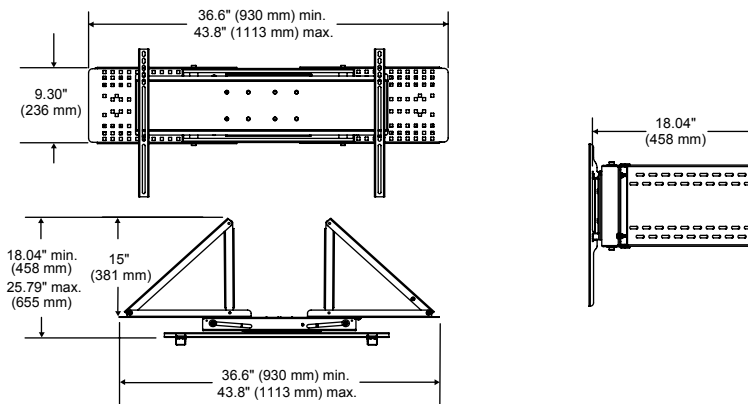

CM850(-S)

## MODELS

### Universal Kitted Models:

Includes SP850-UNL mount  
Includes standard hardware (hex or Phillips) for attaching display to mount

<b>CM850</b>	Black
<b>CM850-S</b>	Silver

## DISPLAY ADAPTER



### Mounting Pattern

Universal Models:	729 x 433mm (28.70"W x 17.05"H)
-------------------	------------------------------------

## SPECIFICATIONS



### Distance from Corner

18.04"-25.79" (458-655mm)



### Tilt | Swivel | Roll

0°, 5° or 10° | ±45° | ±1°



### Max Load

150lb (68kg)

### Product Dimensions (W x H x D)

36.60"-43.08" x 9.30"  
x 18.04"-25.79"  
(930-1113 x 236 x 458-655mm)

### Mounting Surfaces

Wood stud, concrete  
and cinder block

### Ship Weight

Box 1:	30.5lb (13.8kg)
Box 2:	39lb (17.7kg)

## CERTIFICATIONS

RoHS

MADE IN USA

## ACCESSORIES



**ACC324(-S):**  
Corner Mount Shelf ..... pg# 198



**ACC930:**  
Fastener Kit  
for Speaker Mounts ..... pg# 199

To verify mount compatibility with any flat panel display or projector model use MountFinder™ at [www.peerless-av.com](http://www.peerless-av.com)



CALL: 630-375-5100  
800-865-2112



FAX: 630-820-8537  
800-359-6500



E-MAIL:  
[info@peerless-av.com](mailto:info@peerless-av.com)



ONLINE:  
[www.peerless-av.com](http://www.peerless-av.com)



# Corner Mount

For 32" to 60" Flat Panel Displays

## MODELS

### Dedicated Model:

For 32"-50" displays  
Require compatible flat/tilt wall mount

**CM50** Black  
**CM50-S** Silver

For 40"-60" displays  
Require compatible flat/tilt wall mount

**CM60** Black  
**CM60-S** Silver

## DISPLAY ADAPTER

**Dedicated Model:** Requires compatible flat/tilt wall mount to be purchased separately. Compatible flat/tilt models include SF/ST640/650/660, PF/PT640/660 and ONE-TP. See pages 35-37, 43-45, 63-64, 67-68 and 80.

## SPECIFICATIONS



### Distance from Corner

**CM50(-S):** 15" (381mm)  
**CM60(-S):** 15" (381mm)



### Max Load

**CM50(-S):** 175lb (79kg)  
**CM60(-S):** 200lb (90kg)

### Product Dimensions (W x H x D)

**CM50(-S):** 36.60"-43.80" x 9.30" x 15.00"  
(930-1113 x 236 x 381mm)  
**CM60(-S):** 36.60"-60.00" x 9.30" x 15.00"  
(930-1524 x 236 x 381mm)

### Mounting Surfaces

Wood stud, concrete and cinder block

### Ship Weight

**CM50(-S):** 30lb (13.6kg)  
**CM60(-S):** 38lb (17.2kg)

## CERTIFICATIONS



## ACCESSORIES



**ACC324(-S):**  
Corner Mount Shelf ..... pg# 198



**ACC930:**  
Fastener Kit  
for Speaker Mounts ..... pg# 199

1. Allows display to fit in corner where space is limited
2. CM50(-S) wall units expand to support compatible flat/tilt wall mounts for flat panel displays from 32"-50"
3. CM60(-S) includes additional support plate to accommodate compatible flat/tilt wall mounts for flat panel displays from 40"-60"
4. Wall units accommodate speakers when used with smaller displays (wall unit maybe visible with some smaller displays)
5. Optional shelf available for AV components

### Dedicated Models

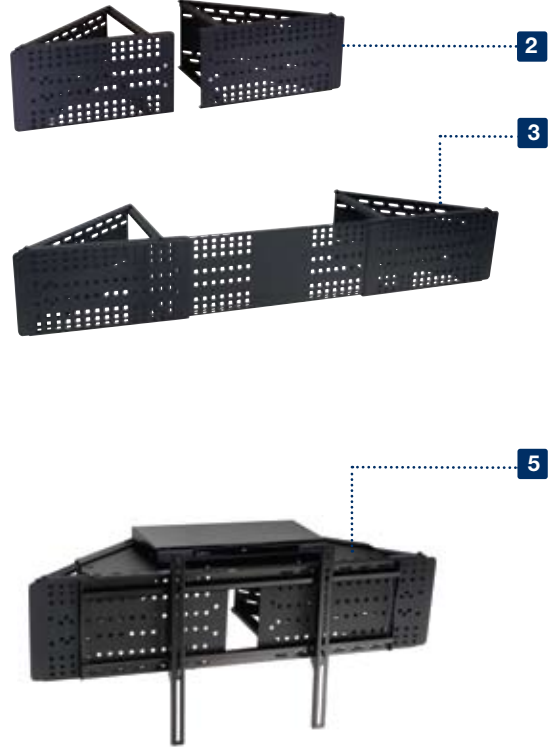

## TECHNICAL DRAWINGS

For expanded product information and technical data visit [www.peerless-av.com](http://www.peerless-av.com)

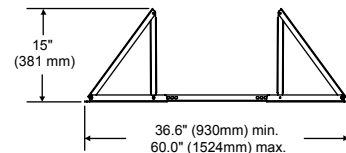
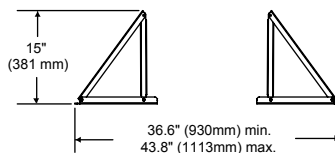
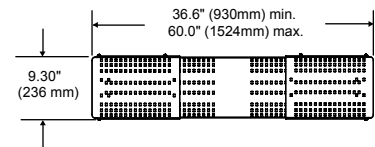
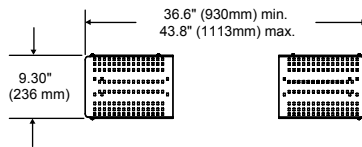

CM50(-S)

CM60(-S)

To verify mount compatibility with any flat panel display or projector model use MountFinder™ at [www.peerless-av.com](http://www.peerless-av.com)



CALL: 630-375-5100  
800-865-2112



FAX: 630-820-8537  
800-359-6500



E-MAIL:  
[info@peerless-av.com](mailto:info@peerless-av.com)



ONLINE:  
[www.peerless-av.com](http://www.peerless-av.com)

# Conversion Kit

For up to 65" Flat Panel Displays

1. Retrofits any Jumbo® single or double wall arm
2. Connects to any 1.5" (38.1mm) NPT pipe
3. 360° swivel for ceiling applications
4. Tilts up to 20°
5. Places flat panel display in the same location as previous CRT display
6. PLCK-UNL includes universal adapter plate for 32" to 65" displays, tilt box, extension column and connector
7. PLCK-1 includes tilt box, extension column and connector. Requires display-specific adapter plate



Patented

For expanded product information and technical data visit [www.peerless-av.com](http://www.peerless-av.com)

## TECHNICAL DRAWINGS

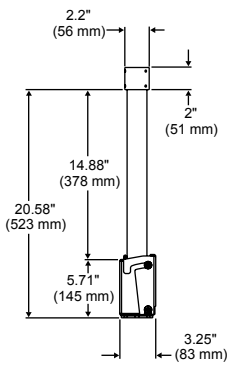

**PLCK-1, PLCK-UNL**  
(without adapter plate)

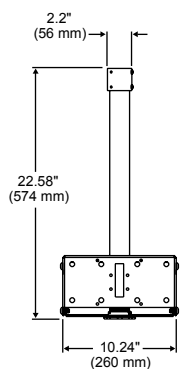

**PLCK-1, PLCK-UNL**  
(without adapter plate)

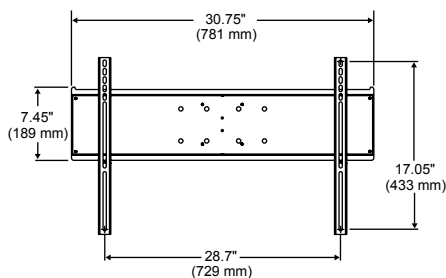

**ADAPTER BRACKET DETAIL (PLCK-UNL ONLY)**

## MODELS

### Universal Models:

Includes theft resistant hardware for attaching display to mount  
**PLCK-UNL** Black

### Dedicated Models:

Display adapter purchased separately\*  
**PLCK-1** Black

\* Dedicated adapter plates come in flat black and include security fasteners

## DISPLAY ADAPTER



### Mounting Pattern

**Universal Models:** 729 x 433mm (28.70"W x 17.05"H)

**Dedicated Models:** Requires display-specific adapter to be purchased separately.

## SPECIFICATIONS



### Distance from Ceiling

**Universal Models:** 27.60" (701mm)

**Dedicated Models:** 22.58" (574mm)



### Tilt | Swivel

20° | 360°



### Max Load

125lb (56kg)

### Product Dimensions (W x H x D)

**Universal Models:** 30.75" x 27.60" x 4.60" (781 x 701 x 116mm)

**Dedicated Models:** 10.24" x 22.58" x 3.25" (260 x 574 x 83mm)

### Mounting Surfaces

Attached to Jumbo single wall arm, double wall arm models and 1.5" - 1.5" (38-292mm) NPT pipe

### Ship Weight

**Universal Models:** 23.9lb (10.8kg)

**Dedicated Models:** 14.5lb (6.6kg)

## CERTIFICATIONS



## ACCESSORIES



**ACC, CMJ, DCS, DCT Models:**  
 Ceiling Plates ..... pg# 190-192



**AEC, ALU and EXT Models:**  
 Ceiling Extensions ..... pg# 193

To verify mount compatibility with any flat panel display or projector model use MountFinder™ at [www.peerless-av.com](http://www.peerless-av.com)



**CALL:** 630-375-5100  
800-865-2112



**FAX:** 630-820-8537  
800-359-6500



**E-MAIL:**  
info@peerless-av.com



**ONLINE:**  
[www.peerless-av.com](http://www.peerless-av.com)





# Ceiling Mount

For 15" to 24" Flat Panel Displays

## MODELS

### Universal Models:

Includes theft resistant hardware for attaching display to mount

With 9.80"-13.90" (249-353mm) extension:

- PC930A** Black
- PC930A-S** Silver
- PC930A-W** White

With 13.78"-21.89" (350-556mm) extension:

- PC930B** Black
- PC930B-S** Silver
- PC930B-W** White

With 20.24"-34.02" (514-864mm) extension:

- PC930C** Black
- PC930C-S** Silver
- PC930C-W** White

## DISPLAY ADAPTER

### VESA® Pattern

Universal Models: 75 and 100mm

## SPECIFICATIONS

### Distance from Ceiling

- PC930A(-S)(-W): 9.80"-13.83" (249-351mm)
- PC930B(-S)(-W): 13.78"-21.89" (350-556mm)
- PC930C(-S)(-W): 20.24"-34.02" (514-864mm)

### Tilt | Swivel

+15/-5° | 360°

### Max Load

50lb (22kg)

### Product Dimensions (W x H x D)

- PC930A(-S)(-W): 6.50" x 9.80"-13.90" x 6.50"  
(165 x 249-353 x 165mm)
- PC930B(-S)(-W): 6.50" x 13.78"-21.89" x 6.50"  
(165 x 350-556 x 165mm)
- PC930C(-S)(-W): 6.50" x 20.24"-34.02" x 6.50"  
(165 x 514-864 x 165mm)

### Mounting Surfaces

Wood joist, concrete and truss

### Ship Weight

- PC930A(-S)(-W): 4.85lb (2.20kg)
- PC930B(-S)(-W): 5.4lb (2.44kg)
- PC930C(-S)(-W): 6.64lb (3.01kg)

## CERTIFICATIONS



1. VESA® 75 and 100mm compliant
2. Continuous tilt of +15/-5° with optional lock in 5° increments
3. Swivel adjustment within ceiling plate for display placement opportunities
4. Internal cable management within extension channels for clean, clutter-free appearance
5. Safety catch designed into extension channels to ensure user and equipment safety



## TECHNICAL DRAWINGS

For expanded product information and technical data visit [www.peerless-av.com](http://www.peerless-av.com)

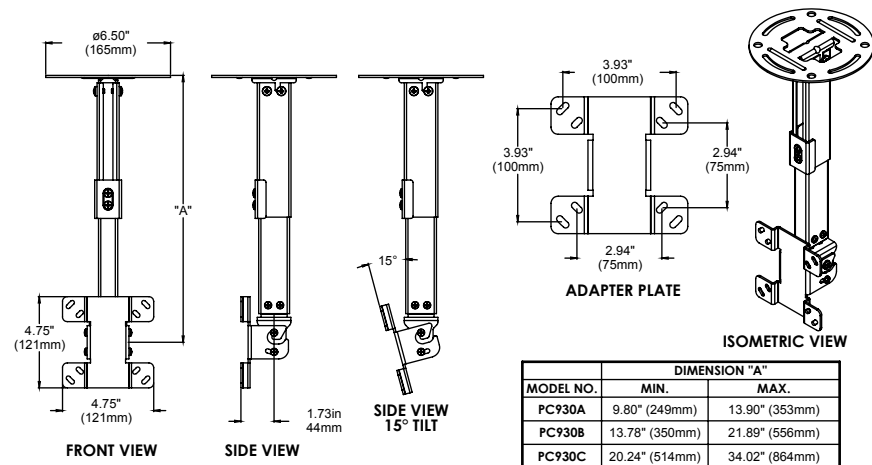

To verify mount compatibility with any flat panel display or projector model use MountFinder™ at [www.peerless-av.com](http://www.peerless-av.com)



CALL: 630-375-5100  
800-865-2112



FAX: 630-820-8537  
800-359-6500



E-MAIL: [info@peerless-av.com](mailto:info@peerless-av.com)



ONLINE: [www.peerless-av.com](http://www.peerless-av.com)

# Ceiling Mount

For 15" to 37" Flat Panel Displays

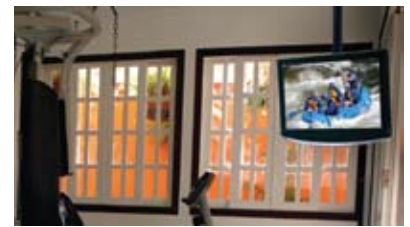

FLAT PANEL MOUNTS

1. VESA® 75, 100, 200 x 100 and 200 x 200mm compliant
2. Continuous tilt of +15/-5° with optional lock in 5° increments
3. Swivel adjustment within ceiling plate for display placement opportunities
4. Internal cable management within extension channels for clean, clutter-free appearance
5. Safety catch designed into extension channels to ensure user and equipment safety
6. Compatible with flat panels that use M8 screws

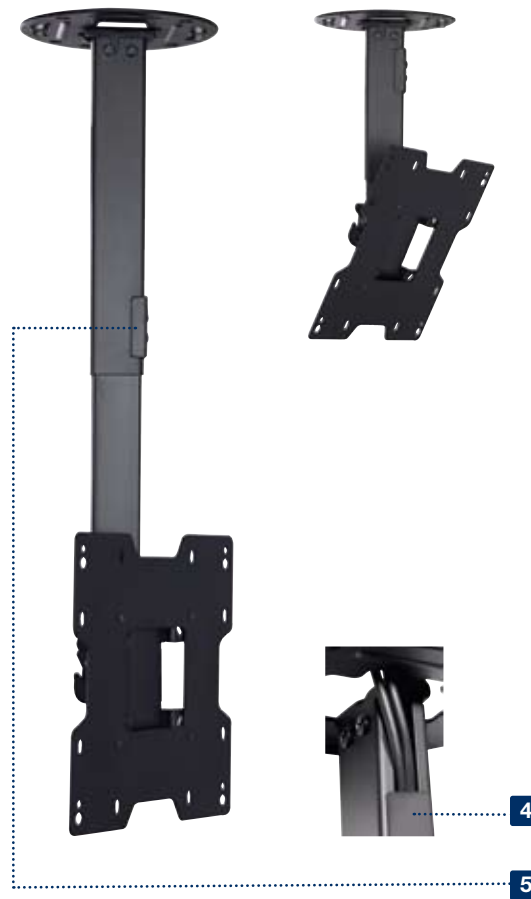

For expanded product information and technical data visit [www.peerless-av.com](http://www.peerless-av.com)

## TECHNICAL DRAWINGS

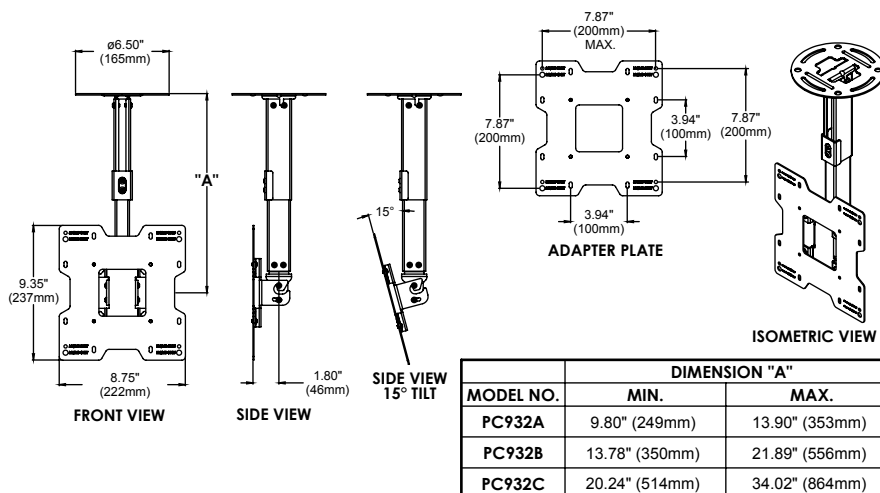

## MODELS

### Universal Models:

Includes theft resistant hardware for attaching display to mount

With 9.80"-13.90" (249-353mm) extension:

**PC932A** Black  
**PC932A-S** Silver  
**PC932A-W** White

With 13.78"-21.89" (350-556mm) extension:

**PC932B** Black  
**PC932B-S** Silver  
**PC932B-W** White

With 20.24"-34.02" (514-864mm) extension:

**PC932C** Black  
**PC932C-S** Silver  
**PC932C-W** White

## DISPLAY ADAPTER



### VESA® Pattern

Universal Models: 75, 100, 200 x 100 and 200 x 200mm

## SPECIFICATIONS



### Distance from Ceiling

PC932A(-S)(-W): 9.80"-13.90" (249-353mm)  
 PC932B(-S)(-W): 13.78"-21.89" (350-556mm)  
 PC932C(-S)(-W): 20.24"-34.02" (514-864mm)



### Tilt | Swivel

+15/-5° | 360°



### Max Load

80lb (36kg)

### Product Dimensions (W x H x D)

PC932A(-S)(-W): 8.75" x 9.80"-13.90" x 6.50" (222 x 249-353 x 165mm)  
 PC932B(-S)(-W): 8.75" x 13.78"-21.89" x 6.50" (222 x 350-556 x 165mm)  
 PC932C(-S)(-W): 8.75" x 20.24"-34.02" x 6.50" (222 x 514-864 x 165mm)

### Mounting Surfaces

Wood joist, concrete and truss

### Ship Weight

PC932A(-S)(-W): 6.4lb (2.90kg)  
 PC932B(-S)(-W): 6.85lb (3.11kg)  
 PC932C(-S)(-W): 8.1lb (3.67kg)

## CERTIFICATIONS



EN 60065



To verify mount compatibility with any flat panel display or projector model use MountFinder™ at [www.peerless-av.com](http://www.peerless-av.com)



CALL: 630-375-5100  
800-865-2112



FAX: 630-820-8537  
800-359-6500



E-MAIL: [info@peerless-av.com](mailto:info@peerless-av.com)



ONLINE: [www.peerless-av.com](http://www.peerless-av.com)





# Ceiling Mount

For 13" to 29" Flat Panel Displays

## MODELS

### Universal Models:

Includes theft resistant hardware for attaching display to mount

<b>LCC-18</b>	Black
<b>LCC-18S</b>	Silver
<b>LCC-36</b>	Black
<b>LCC-36S</b>	Silver

### Universal Models with Cable Management Covers:

Includes theft resistant hardware for attaching display to mount

<b>LCC-18-C</b>	Black
<b>LCC-18-CS</b>	Silver
<b>LCC-36-C</b>	Black
<b>LCC-36-CS</b>	Silver

## DISPLAY ADAPTER

### VESA® Pattern

Universal Models: 75 and 100mm

## SPECIFICATIONS

### Distance from Ceiling

LCC-18(S):	19.35"-32.35" (491-822mm)
LCC-18-C(S):	20.26"-33.26" (515-845mm)
LCC-36(S):	36.85"-49.85" (936-1266mm)
LCC-36-C(S):	37.76"-50.76" (959-1289mm)

### Tilt | Swivel

+20/-5° | 360°

### Max Load

40lb (18kg)

### Product Dimensions (W x H x D)

LCC-18(S):	5.00" x 19.35"-32.35" x 3.00" (127 x 491-822 x 76mm)
LCC-18-C(S):	6.33" x 20.26"-33.26" x 6.33" (161 x 515-845 x 161mm)
LCC-36(S):	5.00" x 36.85"-49.85" x 3.00" (127 x 936-1266 x 76mm)
LCC-36-C(S):	6.33" x 37.76"-50.76" x 6.33" (161 x 959-1289 x 161mm)

### Mounting Surfaces

Wood stud, concrete and various other applications (Requires accessory)

### Ship Weight

LCC-18(S):	4.6lb (2.1kg)
LCC-18-C(S):	7.3lb (3.3kg)
LCC-36(S):	6.2lb (2.8kg)
LCC-36-C(S):	10.6lb (4.8kg)

## CERTIFICATIONS

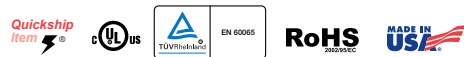

## ACCESSORIES



**ACC, CMJ, DCS, DCT Models:**  
Ceiling Plates ..... pg# 190-192



**AEC, ALU and EXT Models:**  
Ceiling Extensions ..... pg# 193



**ACC109:**  
Extension Column Connector ... pg# 193

- VESA® 75 and 100mm compliant with non-VESA® display adapter plates also available
- Cable management cover models available for a clean look
- Continues tilt of +20/-5°
- 0.75" (19mm) extension pipe for low-profile appearance and includes adapter to 1.5" (38mm) NPT pipe
- Portrait or landscape orientation
- Mounts in standard or face-down display position



## TECHNICAL DRAWINGS

For expanded product information and technical data visit [www.peerless-av.com](http://www.peerless-av.com)

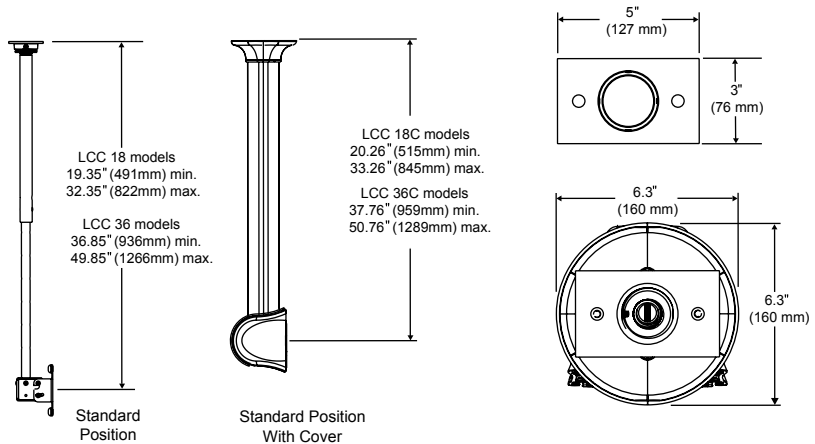

To verify mount compatibility with any flat panel display or projector model use MountFinder™ at [www.peerless-av.com](http://www.peerless-av.com)



CALL: 630-375-5100  
800-865-2112



FAX: 630-820-8537  
800-359-6500



E-MAIL:  
[info@peerless-av.com](mailto:info@peerless-av.com)



ONLINE:  
[www.peerless-av.com](http://www.peerless-av.com)

# Ceiling Mount

For 32" to 71" Flat Panel Displays

- 0° to 20° adjustable tilt and 360° swivel
- Uses standard 1.5" (38mm) NPT pipe
- Mount display vertically or horizontally with dedicated adapter plate
- Simple hook-on display installation



For expanded product information and technical data visit [www.peerless-av.com](http://www.peerless-av.com)

## TECHNICAL DRAWINGS

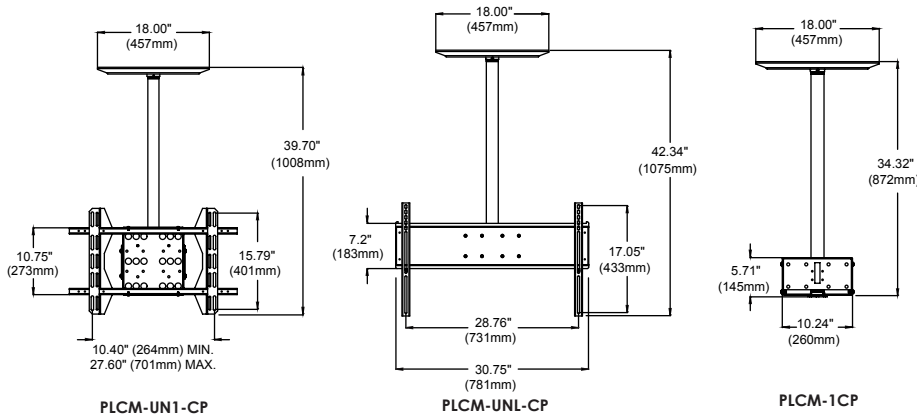

Model	Screen Size	Width	Height	Depth	Contents	Max Load	Ship Weight
PLCM-UNL-CP	32"-65"	30.75" (781mm)	42.34" (1075mm)	4.43" (112mm)	Ceiling plate, adapter, column, base mount	200lb (90kg)	33.3lb (15.1kg)
PLCM-UNL	32"-65"	30.75" (781mm)	41.54" (1055mm)	4.43" (112mm)	Adapter, column, base mount	200lb (90kg)	30.3lb (13.74kg)
PLCM-UN1-CP	32"-55"	27.60" (701mm)	39.70" (1008mm)	3.92" (99mm)	Ceiling plate, adapter, column, base mount	125lb (56kg)	30.1lb (13.6kg)
PLCM-UN1	32"-55"	27.60" (701mm)	38.91" (988mm)	3.92" (99mm)	Adapter, column, base mount	125lb (56kg)	27.4lb (12.4kg)
PLCM-1CP	Up to 71"	18.00" (457mm)	34.32" (872mm)	3.61" (91mm)	Ceiling plate, column, base mount	225lb (102kg)	18.7lb (8.4kg)
PLCM-1	Up to 71"	10.24" (260mm)	33.50" (850mm)	3.25" (82mm)	Column, base mount	225lb (102kg)	16lb (7.2kg)
PLCM-2	Up to 71"	10.24" (260mm)	5.71" (145mm)	3.25" (82mm)	Base mount	225lb (102kg)	7.5lb (3.4kg)

To verify mount compatibility with any flat panel display or projector model use MountFinder™ at [www.peerless-av.com](http://www.peerless-av.com)



CALL: 630-375-5100  
800-865-2112



FAX: 630-820-8537  
800-359-6500



E-MAIL: [info@peerless-av.com](mailto:info@peerless-av.com)



ONLINE: [www.peerless-av.com](http://www.peerless-av.com)

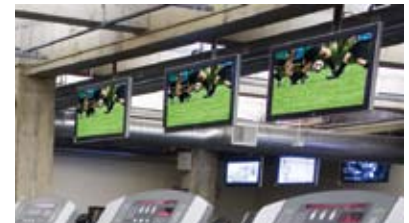

FLAT PANEL MOUNTS

## MODELS

**Universal Models:** (See chart for display size compatibility)

Includes theft resistant hardware for attaching display to mount

<b>PLCM-UNL-CP</b>	Black
<b>PLCM-UNL</b>	Black
<b>PLCM-UN1-CP</b>	Black
<b>PLCM-UN1</b>	Black

**Dedicated Models:** (See chart for display size compatibility)

Display Adapter Purchased Separately\*

<b>PLCM-1</b>	Black
<b>PLCM-1CP</b>	Black
<b>PLCM-2</b>	Black

\*Dedicated adapter plates come in flat black and include security fasteners

## DISPLAY ADAPTER



### Mounting Pattern

**Universal PLCM-UNL Models:** 731 x 433mm (28.76"W x 17.05"H)

**Universal PLCM-UN1 Models:** 701 x 401mm (27.60"W x 15.70"H)



### VESA® Pattern

**Universal Models:** Up to 600 x 400mm

**Dedicated Models:** Requires display-specific adapter to be purchased separately.

## SPECIFICATIONS



### Distance from Ceiling

See chart



### Tilt | Swivel

+20° | 360°



### Max Load

See chart

### Product Dimensions (W x H x D)

See chart

### Mounting Surfaces

Wood joist, concrete and various other applications (May require accessory)

### Ship Weight

See chart

## CERTIFICATIONS



## ACCESSORIES



**ACC, CMJ, DCS, DCT Models:**  
Ceiling Plates ..... pg# 190-192



**AEC, ALU and EXT Models:**  
Ceiling Extensions ..... pg# 193



# Multi-Display Ceiling Mount

For 32" to 50" Flat Panel Displays

## MODELS

### Dedicated Models:

Includes theft resistant hardware for attaching display to mount. Display adapter purchased separately\*

<b>MDJ700</b>	In-line Display	Black
<b>MDJ710</b>	In-line Display	Black
<b>MDJ720</b>	In-line Display	Black
<b>MDJ701</b>	Curvilinear Display	Black
<b>MDJ711</b>	Curvilinear Display	Black
<b>MDJ721</b>	Curvilinear Display	Black
<b>MDJ760</b>	Circular Display	Black

\* Dedicated adapter plates come in flat black and include security fasteners

## DISPLAY ADAPTER

**Dedicated Models:** Requires display-specific adapter to be purchased separately.

## SPECIFICATIONS

### Distance from Ceiling

1'-12" (305-3658mm)  
Varies depending on ceiling plate and extension column used

### Tilt | Swivel

+20° | 360°

### Max Load

600-1200lb (272-545kg)  
Depending on ceiling attachments used

### Product Dimensions (Pipe Length)

<b>MDJ700/701:</b>	120"	(3048mm)
<b>MDJ710/711:</b>	180"	(4572mm)
<b>MDJ720/721:</b>	240"	(6096mm)
<b>MDJ760:</b>	48"	(1220mm)

### Mounting Surfaces

Virtually all ceiling surfaces  
(Requires accessory)

### Ship Weight

<b>MDJ700:</b>	31lb (14.1kg)
<b>MDJ710:</b>	45lb (20.4kg)
<b>MDJ720:</b>	62lb (28.1kg)
<b>MDJ701:</b>	27lb (20.4kg)
<b>MDJ711:</b>	35lb (15.9kg)
<b>MDJ721:</b>	56lb (24.5kg)
<b>MDJ760:</b>	45lb (20.4kg)

## CERTIFICATIONS



## ACCESSORIES

See chart for components needed to complete installation .....pg# 97

1. Multi-Display ceiling mount for 3 to 4 flat panel displays
2. Three different configurations: in-line, curvilinear, and circular
3. Choose desired ceiling drop length and drop length of equipment from pipe
4. 0° to 20° adjustable tilt
5. 360° swivel for each display

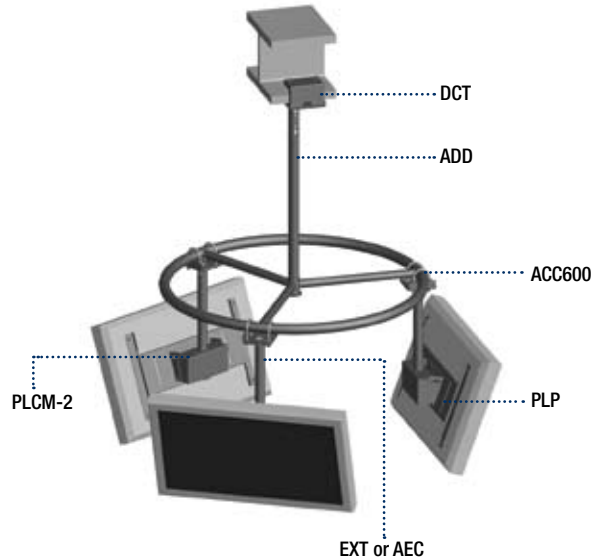

Circular configuration



In-line configuration



Curvilinear configuration

To verify mount compatibility with any flat panel display or projector model use MountFinder™ at [www.peerless-av.com](http://www.peerless-av.com)



CALL: 630-375-5100  
800-865-2112



FAX: 630-820-8537  
800-359-6500



E-MAIL: [info@peerless-av.com](mailto:info@peerless-av.com)



ONLINE: [www.peerless-av.com](http://www.peerless-av.com)

## CIRCULAR

\* Columns over 9' will be covered in vinyl

Display Size	Number of displays	MDJ model*	PLCM-2 display mount	PLP display adapter plate (see MountFinder™)	EXT or ADJ extension column (connects PLCM-2 to ACC600)	ACC600 interface bracket to MDJ mount	ADD* support extension column	DCT ceiling decoupler
32"-37"	3	MDJ760	3	3	3	3	1	1
40"-42"	3	MDJ760	3	3	3	3	1	1
50"	3	MDJ760	3	3	3	3	1	1
32"-37"	4	MDJ760	4	4	4	4	1	1
40"-42"	4	MDJ760	4	4	4	4	1	1



## IN-LINE

Display Size	Number of displays	MDJ model	PLCM-2 display mount	PLP display adapter plate (see MountFinder™)	EXT or ADJ extension column (connects PLCM-2 to ACC600)	ACC600 interface bracket to MDJ mount	ADD support extension column	DCT ceiling decoupler
32"-37"	3	MDJ700	3	3	3	5	2	2
40"-42"	3	MDJ700	3	3	3	5	2	2
50"	3	MDJ710	3	3	3	5	2	2
32"-37"	4	MDJ700	4	4	4	6	2	2
40"-42"	4	MDJ710	4	4	4	6	2	2
50"	4	MDJ720	4	4	4	6	2	2

## CURVILINEAR

Display Size	Number of displays	MDJ model	PLCM-2 display mount	PLP display adapter plate (see MountFinder™)	EXT or ADJ extension column (connects PLCM-2 to ACC600)	ACC600 interface bracket to MDJ mount	ADD support extension column	DCT ceiling decoupler
32"-37"	3	MDJ701	3	3	3	5	2	2
40"-42"	3	MDJ701	3	3	3	5	2	2
50"	3	MDJ711	3	3	3	5	2	2
32"-37"	4	MDJ701	4	4	4	6	2	2
40"-42"	4	MDJ711	4	4	4	6	2	2
50"	4	MDJ721	4	4	4	6	2	2

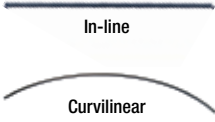
## MULTI-DISPLAY SYSTEM COMPONENTS

Multi-Display Mount	Model	Length	Ring Diameter	Pipe Diameter	Load Capacity	Ship Weight
 In-line Curvilinear	MDJ700 (in-line)	120" (3048mm)	NA	1.90" OD	1000lb (453kg)	31lb (14.1kg)
	MDJ710 (in-line)	180" (4572mm)	NA	1.90" OD	1200lb (544kg)	45lb (20.4kg)
	MDJ720 (in-line)	240" (6096mm)	NA	1.90" OD	1500lb (680kg)	62lb (28.1kg)
	MDJ701 (curved)	120" (3048mm)	NA	1.90" OD	1000lb (453kg)	27lb (12.2kg)
	MDJ711 (curved)	180" (4572mm)	NA	1.90" OD	1200lb (544kg)	35lb (15.9kg)
	MDJ721 (curved)	240" (6096mm)	NA	1.90" OD	1500lb (680kg)	56lb (25.4kg)
 Circular	MDJ760 (circular)	NA	48" (122cm)	1.90" OD	600lb (272kg)	45lb (20.4kg)

Screen Mount	Model	Ship Weight
 PLCM-2 PLP display adapter required. See MountFinder™ to verify display compatibility. See page 95 for details		7.5lb (3.40kg)

Multi-Display Interface Bracket	Model	Description	Load Capacity	Ship Weight
 ACC600 See page 191 for details		Interfaces between flat panel mount to MDJ mount, and MDJ mount to ceiling support structure.	1200lb (544kg)	3.8lb (1.7kg)

Fixed or Adjustable Extension Columns for Attaching Mount	Model	Drop Length*	
 EXT/AEC/ALU models See page 193 for details		6"-12' (152-3657mm)	* Fixed length columns provide 6" to 10' (152.4-3048mm) drop lengths. Adjustable length columns provide 6" to 12' (152-3657mm) drop lengths.

Fixed or Adjustable Extension Columns for Ceiling Decouplers	Model	Drop Length*	
 ADD models See page 194 for details		12"-12' (304-3657mm)	* Fixed length columns provide 1' to 10' (304-3048mm) drop lengths. Adjustable length columns provide 1' to 12' (304-3657mm) drop lengths.

Ceiling Decoupler	Model	Ceiling type	Load Capacity	Ship Weight
 DCS400    DCT300    DCT500-900 See page 191 for details	DCS400	For structural or finished ceiling	1200lb (544kg)	7.8lb (3.5kg)
	DCT300	For truss ceiling	1200lb (544kg)	4.6lb (2.1kg)
	DCT500	For I-Beams	600lb (272kg)	9.4lb (4.3kg)
	DCT600	For I-Beams	600lb (272kg)	13.1lb (6kg)
	DCT700	For I-Beams	600lb (272kg)	13.6lb (6.2kg)
	DCT800	For I-Beams	600lb (272kg)	14lb (6.4kg)
	DCT900	For I-Beams	600lb (272kg)	9lb (4.1kg)

To verify mount compatibility with any flat panel display or projector model use MountFinder™ at [www.peerless-av.com](http://www.peerless-av.com)



CALL: 630-375-5100  
800-865-2112



FAX: 630-820-8537  
800-359-6500



E-MAIL:  
[info@peerless-av.com](mailto:info@peerless-av.com)



ONLINE:  
[www.peerless-av.com](http://www.peerless-av.com)



# Dual-Display Ceiling Mount

For 30" to 65" Flat Panel Displays

## MODELS

### Dedicated Models:

Includes theft resistant hardware for attaching display to mount  
**PLB-1** Black

*\* Dedicated adapter plates come in flat black and include security fasteners*

## DISPLAY ADAPTER

**Dedicated Models:** Requires display-specific adapter to be purchased separately.

## SPECIFICATIONS

	<b>Distance from Ceiling</b>	Varies depending on ceiling plate and extension column used.
	<b>Tilt   Swivel</b>	20°   360°
	<b>Max Load</b>	300lb (136kg)
<b>Product Dimensions (W x H x D)</b>		10.00" x 5.40" x 9.46" (254 x 137 x 240mm)
<b>Mounting Surfaces</b>		Virtually all ceiling structures (Requires accessory)
<b>Ship Weight</b>		21lb (9.5kg)

## CERTIFICATIONS



## ACCESSORIES

**DCS, DCT Models:**  
Ceiling Plates .....pg# 191

**ADD Models:**  
Ceiling Extensions .....pg# 194

**AEC, ALU and EXT Models\*:**  
Ceiling Extensions ..... pg# 193

\* Excluding EXT002, EXT006 and AEC609

**PLP-UNL:**  
Universal Adapter Plate  
Contact Peerless-AV Customer Care for more information.

1. Entire unit swivels 360° with swivel-stop feature
2. 20° adjustable tilt for each display
3. Landscape or portrait orientation (dedicated adapter plate required, sold separately)
4. Requires extension column and ceiling plate, sold separately



## TECHNICAL DRAWINGS

For expanded product information and technical data visit [www.peerless-av.com](http://www.peerless-av.com)

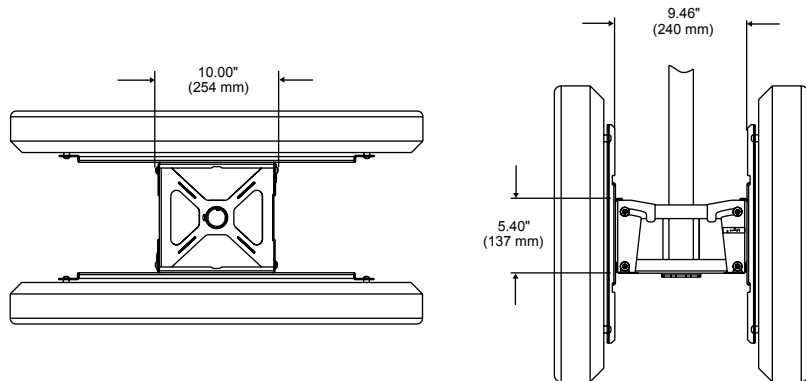

To verify mount compatibility with any flat panel display or projector model use MountFinder™ at [www.peerless-av.com](http://www.peerless-av.com)



CALL: 630-375-5100  
800-865-2112



FAX: 630-820-8537  
800-359-6500



E-MAIL: [info@peerless-av.com](mailto:info@peerless-av.com)



ONLINE: [www.peerless-av.com](http://www.peerless-av.com)



# Tabletop Stand

For 32" to 50" Flat Panel Displays

1. Base can either rest in a fixed position or swivel with 360° rotation
2. 5° backward and 10° forward tilt
3. Internal cable management to keep cables out of the way
4. Black graphite laminate base
5. Felt ring on bottom of base protects tabletop surface



Patented

For expanded product information and technical data visit [www.peerless-av.com](http://www.peerless-av.com)

## TECHNICAL DRAWINGS

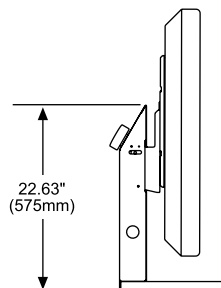
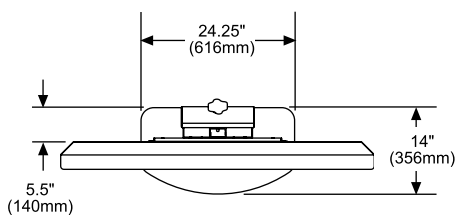

FLAT PANEL MOUNTS

## MODELS

### Dedicated Models:

Includes theft resistant hardware for attaching display to mount

**PLT-BLK** Black

*\*Dedicated adapter plates come in flat black and include security fasteners*

## DISPLAY ADAPTER

**Dedicated Models:** Requires display-specific adapter to be purchased separately.

## SPECIFICATIONS

	<b>Distance from Base</b>	5.50" (140mm)
	<b>Tilt   Swivel</b>	+10°/-5°   360°
	<b>Max Load</b>	150lb (68kg)
<b>Product Dimensions (W x H x D)</b>		
		24.25" x 22.63" x 14.00" (616 x 575 x 356mm)
<b>Mounting Surfaces</b>		
		Tabletop
<b>Ship Weight</b>		
		32.5lb (14.74kg)

## CERTIFICATIONS



## ACCESSORIES



**PLP-UNL:**  
Universal Adapter Plate  
Contact Peerless-AV Customer Care for more information.

To verify mount compatibility with any flat panel display or projector model use MountFinder™ at [www.peerless-av.com](http://www.peerless-av.com)



**CALL:** 630-375-5100  
800-865-2112



**FAX:** 630-820-8537  
800-359-6500



**E-MAIL:**  
[info@peerless-av.com](mailto:info@peerless-av.com)



**ONLINE:**  
[www.peerless-av.com](http://www.peerless-av.com)



# Height-Adjustable Desktop Mount

For 10" to 30" Flat Panel Displays

## MODELS

### Universal Models:

Includes standard hardware (hex or Phillips) for attaching display to mount

**LCH-100** Black

## DISPLAY ADAPTER

### VESA® Pattern

Universal Models: 75 and 100mm

## SPECIFICATIONS



### Distance from Base

5.69" (145mm)



### Tilt | Swivel | Roll

+30°/-50° | ±45° | 90°



### Max Load

25lb (11kg)

### Product Dimensions (W x H x D)

3.56" x 14.15"-18.15" x 5.69"  
(91 x 360-461 x 145mm)

### Mounting Surfaces

Desktop

### Ship Weight

5lb (2.3kg)

1. VESA® 75 and 100mm compliant with non-VESA® adapter plates available
2. Side-to-side swivel can be restricted to ±45° or less
3. 50° upward tilt and 30° downward tilt
4. Height adjustable from 12.37"-16.37" (314-416mm)
5. Comes with external clips for cable management



## CERTIFICATIONS



## TECHNICAL DRAWINGS

For expanded product information and technical data visit [www.peerless-av.com](http://www.peerless-av.com)

## ACCESSORIES



**PTM200(-S):**  
Universal Tablet Cradle .....pg# 78

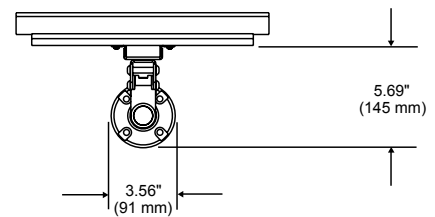
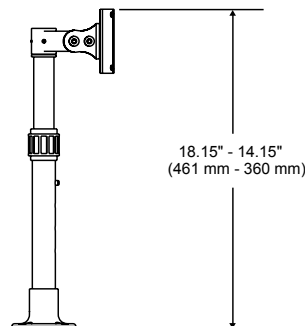

To verify mount compatibility with any flat panel display or projector model use MountFinder™ at [www.peerless-av.com](http://www.peerless-av.com)



CALL: 630-375-5100  
800-865-2112



FAX: 630-820-8537  
800-359-6500



E-MAIL:  
[info@peerless-av.com](mailto:info@peerless-av.com)



ONLINE:  
[www.peerless-av.com](http://www.peerless-av.com)

# Height-Adjustable Desktop Mount

For 10" to 30" Flat Panel Displays

1. VESA® 75 and 100mm compliant with non-VESA® adapter plates available
2. 360° swivel
3. 30° adjustable backward or forward tilt
4. Height adjustment with knob allows screen to travel 9.5" (241mm) up and down the arm and tightens into place



For expanded product information and technical data visit [www.peerless-av.com](http://www.peerless-av.com)

## TECHNICAL DRAWINGS

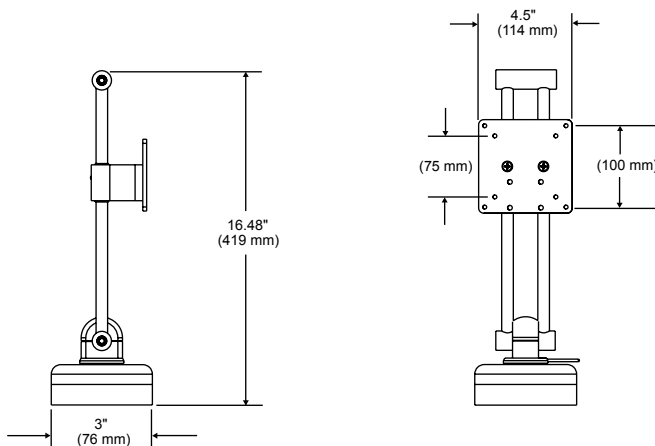

To verify mount compatibility with any flat panel display or projector model use MountFinder™ at [www.peerless-av.com](http://www.peerless-av.com)



CALL: 630-375-5100  
800-865-2112



FAX: 630-820-8537  
800-359-6500



E-MAIL:  
[info@peerless-av.com](mailto:info@peerless-av.com)



ONLINE:  
[www.peerless-av.com](http://www.peerless-av.com)



FLAT PANEL MOUNTS

## MODELS

### Universal Models:

Includes standard hardware (hex or Phillips) for attaching display to mount

**LCV-100**

Silver

## DISPLAY ADAPTER



### VESA® Pattern

Universal Models: 75 and 100mm

## SPECIFICATIONS



### Distance from Base

3.00" (76mm)



### Tilt | Swivel

±30° | 360°



### Max Load

25lb (11kg)

### Product Dimensions (W x H x D)

4.50" x 16.48" x 3.00"  
(114 x 419 x 76mm)

### Mounting Surfaces

Wood and/or wood composite surfaces

### Ship Weight

4.5lb (2.1kg)

## CERTIFICATIONS



## ACCESSORIES



**PTM200(-S):**  
Universal Tablet Cradle .....pg# 78



# 100-Series Desktop Mount

For 12" to 30" Flat Panel Displays

## MODELS

### Universal Models:

Includes standard hardware (hex or Phillips) for attaching display to mount

**LCT100S**      Black

## DISPLAY ADAPTER

### VESA® Pattern

Universal Models: 75 and 100mm

## SPECIFICATIONS



### Distance from Base

2.30" (58mm)



### Tilt | Swivel | Roll

±40° | 180° | 360°



### Max Load

20lb (9kg)



### Landscape to Portrait

Display can be rotated from landscape to portrait without removing the display.

### Product Dimensions (W x H x D)

7.00" x 16.00" x 6.10"  
(178 x 406 x 156mm)

### Mounting Surfaces

Desktop

### Ship Weight

6.2lb (2.8kg)

1. Desk clamp and grommet mount option
2. Aluminium casted arm provides sturdy and durable support
3. Height adjustment up to 12.6" (320mm) on the post
4. Cable management clips to help keep cables out of the way



## TECHNICAL DRAWINGS

For expanded product information and technical data visit [www.peerless-av.com](http://www.peerless-av.com)

## CERTIFICATIONS



## ACCESSORIES



**PTM200(-S):**  
Universal Tablet Cradle .....pg# 78

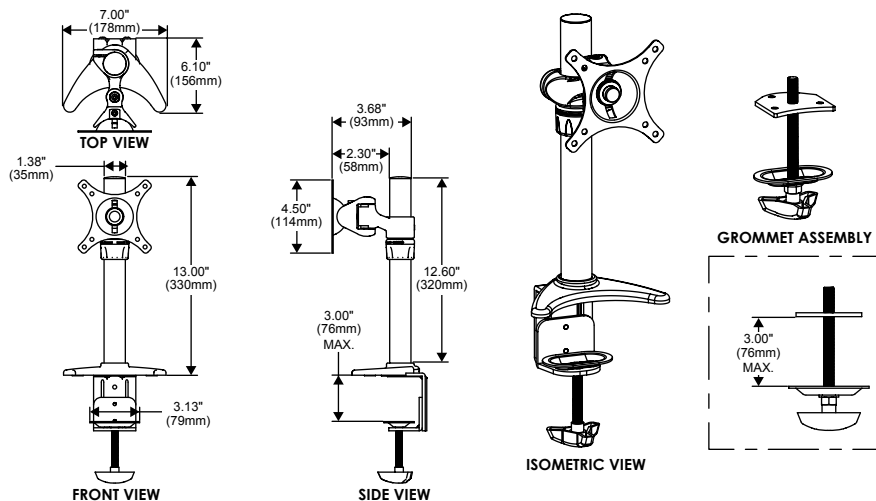

To verify mount compatibility with any flat panel display or projector model use MountFinder™ at [www.peerless-av.com](http://www.peerless-av.com)



CALL: 630-375-5100  
800-865-2112



FAX: 630-820-8537  
800-359-6500



E-MAIL: [info@peerless-av.com](mailto:info@peerless-av.com)



ONLINE: [www.peerless-av.com](http://www.peerless-av.com)

# Articulating Desktop Mount

For 10" to 30" Flat Panel Displays

1. VESA® 75 and 100mm compliant with non-VESA® adapter plates also available
2. Durable gas-strut and ball-joint system for smooth, stable operation
3. Three pivot points with up to 360° swivel
4. Mounting options for all surfaces (desk clamp, desk bolt included)
5. Up to 360° roll to orient display horizontally or vertically
6. Compact retractable design increases work space

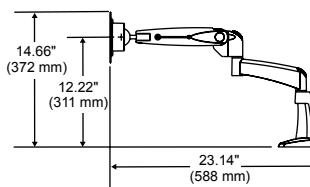
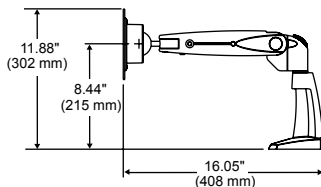
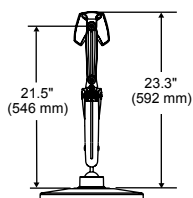
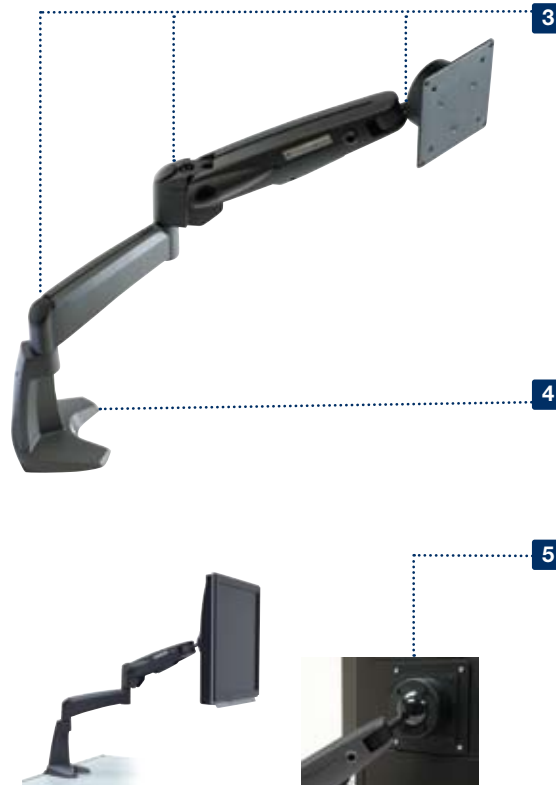

For expanded product information and technical data visit [www.peerless-av.com](http://www.peerless-av.com)

## TECHNICAL DRAWINGS



FLAT PANEL MOUNTS

## MODELS

### Universal Models:

Includes standard hardware (hex or Phillips) for attaching display to mount

**LCT-101** Black

## DISPLAY ADAPTER



### VESA® Pattern

Universal Models: 75 and 100mm

## SPECIFICATIONS



### Distance from Base

16.05"-23.14" (408-588mm)



### Tilt | Swivel | Roll

±60° | 360° | 360°



### Max Load

25lb (11kg)

### Product Dimensions (W x H x D)

4.50" x 23.30" x 16.05"-23.14"  
(115 x 592 x 408-588mm)

### Mounting Surfaces

Desktop

### Ship Weight

12lb (5.4kg)

## CERTIFICATIONS



## ACCESSORIES



**PTM200(-S):**  
Universal Tablet Cradle .....pg# 78

To verify mount compatibility with any flat panel display or projector model use MountFinder™ at [www.peerless-av.com](http://www.peerless-av.com)



**CALL:** 630-375-5100  
800-865-2112



**FAX:** 630-820-8537  
800-359-6500



**E-MAIL:**  
[info@peerless-av.com](mailto:info@peerless-av.com)



**ONLINE:**  
[www.peerless-av.com](http://www.peerless-av.com)





# Dual-Monitor Desktop Mount

For 10" to 24" Flat Panel Displays

## MODELS

### Universal Models:

Includes standard hardware (hex or Phillips) for attaching display to mount

<b>LCT-202</b>	Black
<b>LCT-203</b>	Charcoal

## DISPLAY ADAPTER

### VESA® Pattern

Universal Models: 75 and 100mm

## SPECIFICATIONS

### Distance from Base

6.25" (159mm)

### Tilt | Swivel | Roll

LCT-202:  $\pm 40^\circ$  |  $\pm 20^\circ$  | -  
LCT-203: - |  $\pm 90^\circ$  |  $\pm 10^\circ$

### Max Load

LCT-202: 50lb (23kg)  
LCT-203: 45lb (20kg)

### Product Dimensions (W x H x D)

LCT-202: 29.00" x 15.00" x 9.20"  
(737 x 381 x 235mm)  
LCT-203: 28.20" x 13.10" x 11.40"  
(716 x 333 x 290mm)

### Mounting Surfaces

Desktop

### Ship Weight

LCT-202: 11.5lb (5.23kg)  
LCT-203: 17.5lb (8kg)

## CERTIFICATIONS

LCT-202: **RoHS** 2002/95/EC **Quickship Item**

LCT-203: **RoHS** 2002/95/EC **UL** US **Quickship Item**

## ACCESSORIES



**PTM200(-S):**  
Universal Tablet Cradle .....pg# 78



**ACC450:**  
VESA® 200 x 200mm Accessory Plate  
Contact Peerless Customer Care for more information.

1. Dual display desktop mount eliminates desktop clutter
2. Ergonomically designed to allow you to view multiple displays with minimum effort
3. Designed for fast and effortless assembly and to accommodate various monitor sizes
4. Internal cable management system organizes cables discretely
5. Easy adjustment of displays for the best viewing angle



**LCT-202**  
Aluminum



**LCT-203**  
Plastic

## TECHNICAL DRAWINGS

For expanded product information and technical data visit [www.peerless-av.com](http://www.peerless-av.com)

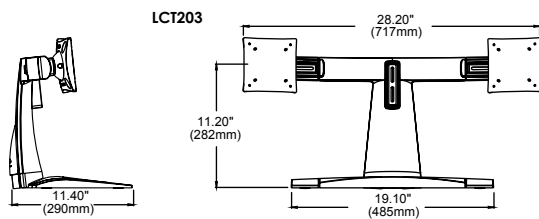
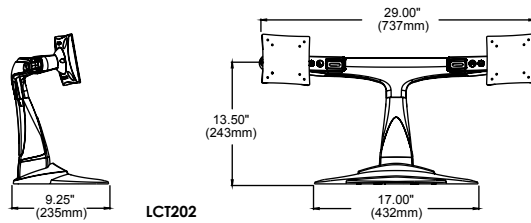

To verify mount compatibility with any flat panel display or projector model use MountFinder™ at [www.peerless-av.com](http://www.peerless-av.com)



CALL: 630-375-5100  
800-865-2112



FAX: 630-820-8537  
800-359-6500



E-MAIL: [info@peerless-av.com](mailto:info@peerless-av.com)



ONLINE: [www.peerless-av.com](http://www.peerless-av.com)

# Dual-Monitor Desktop Mount

For 20" to 30" Flat Panel Displays

1. Dual-monitor desktop mount eliminates desktop clutter requires two square feet of space
2. Holds two displays at same height which allows height adjustment of 3mm on mount bracket
3. Designed for fast and effortless assembly
4. Internal cable management system organizes cables discretely



For expanded product information and technical data visit [www.peerless-av.com](http://www.peerless-av.com)

## TECHNICAL DRAWINGS

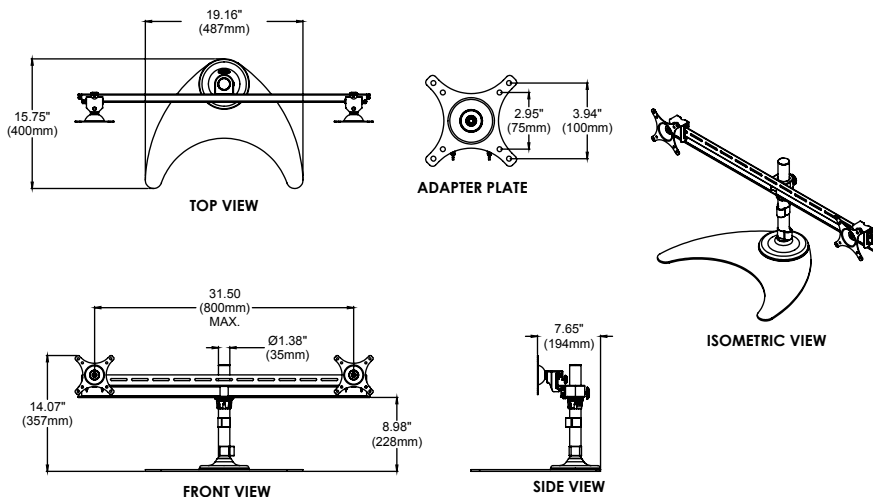

FLAT PANEL MOUNTS

## MODELS

### Universal Models:

Includes standard hardware (hex or Phillips) for attaching display to mount

**LCZ-2F430B** Black

## DISPLAY ADAPTER



VESA® Pattern

Universal Models: 75 and 100mm

## SPECIFICATIONS



Distance from Base

5.30" (134mm)



Roll

360°



Max Load

19.8lb (9kg) per display

Product Dimensions

(W x H x D)

35.40" x 12.20" x 6.10"  
(900 x 327 x 105mm)

Mounting Surfaces

Desktop

Ship Weight

20.7lb (9.42kg)

## CERTIFICATIONS

Quickship Item

RoHS

## ACCESSORIES



**PTM200(-S):**  
Universal Tablet Cradle .....pg# 78



**ACC450:**  
VESA® 200 x 200mm Accessory Plate  
Contact Peerless-AV Customer Care for more information.

To verify mount compatibility with any flat panel display or projector model use MountFinder™ at [www.peerless-av.com](http://www.peerless-av.com)



CALL: 630-375-5100  
800-865-2112



FAX: 630-820-8537  
800-359-6500



E-MAIL:  
[info@peerless-av.com](mailto:info@peerless-av.com)



ONLINE:  
[www.peerless-av.com](http://www.peerless-av.com)



# Triple-Monitor Desktop Mount

For 14" to 24" Flat Panel Displays

## MODELS

### Universal Models:

Includes standard hardware (hex or Phillips) for attaching display to mount

**LCZ-3F419B** Black

## DISPLAY ADAPTER

### VESA® Pattern

Universal Models: 75 and 100mm

## SPECIFICATIONS

### Distance from Base

5.30" (134mm)

### Roll

360°

### Max Load

19.8lb (9kg) per display

### Product Dimensions (W x H x D)

35.40" x 12.90" x 6.10"  
(900 x 327 x 155mm)

### Mounting Surfaces

Desktop

### Ship Weight

21.8lb (9.92kg)

1. Triple-monitor desktop mount eliminates desktop clutter requires two square feet of space
2. Holds three displays at same height which allows height adjustment of 3mm on mount bracket
3. Designed for fast and effortless assembly
4. Internal cable management system organizes cables discretely

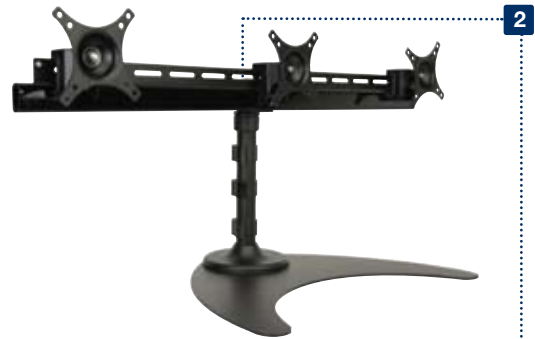

## CERTIFICATIONS



## ACCESSORIES



**PTM200(-S):**  
Universal Tablet Cradle .....pg# 78



**ACC450:**  
VESA® 200 x 200mm Accessory Plate  
Contact Peerless Customer Care for more information.

## TECHNICAL DRAWINGS

For expanded product information and technical data visit [www.peerless-av.com](http://www.peerless-av.com)

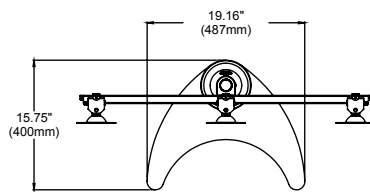

TOP VIEW

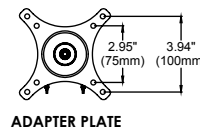

ADAPTER PLATE

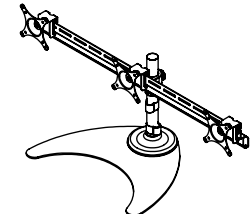

ISOMETRIC VIEW

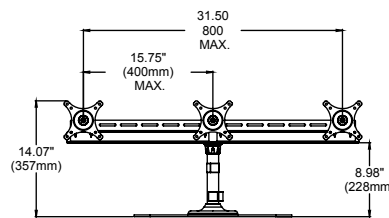

FRONT VIEW

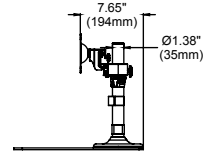

SIDE VIEW

To verify mount compatibility with any flat panel display or projector model use MountFinder™ at [www.peerless-av.com](http://www.peerless-av.com)



CALL: 630-375-5100  
800-865-2112



FAX: 630-820-8537  
800-359-6500



E-MAIL: [info@peerless-av.com](mailto:info@peerless-av.com)



ONLINE: [www.peerless-av.com](http://www.peerless-av.com)

# Quad-Monitor Grommet/Desktop Mount

For 20" to 30" Flat Panel Displays

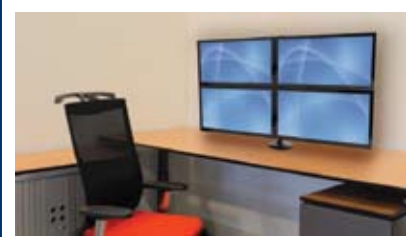

FLAT PANEL MOUNTS

1. Quad-monitor desktop mount eliminates desktop clutter
2. Holds displays at same height which allows height adjustment of 3mm on mount bracket
3. Designed for fast and effortless assembly
4. Internal cable management system organizes cables discretely



LCZ-4F430B



LCZ-4F4G30B

## MODELS

### Universal Models:

Includes standard hardware (hex or Phillips) for attaching display to mount

<b>LCZ-4F4G30B</b>	Grommet Mount	Black
<b>LCZ-4F430B</b>	Desktop Mount	Black

## DISPLAY ADAPTER



### VESA® Pattern

Universal Models: 75 and 100mm

## SPECIFICATIONS



### Distance from Base

5.30" (134mm)



### Roll

360°



### Max Load

19.8lb (9kg) per display

### Product Dimensions (W x H x D)

35.40" x 24.20" x 6.10"  
(900 x 615 x 155mm)

### Mounting Surfaces

Desktop

### Ship Weight

<b>LCZ-4F4G30B:</b>	20.5lb (9.2kg)
<b>LCZ-4F430B:</b>	29.3lb (13.2kg)

## CERTIFICATIONS



For expanded product information and technical data visit [www.peerless-av.com](http://www.peerless-av.com)

## TECHNICAL DRAWINGS

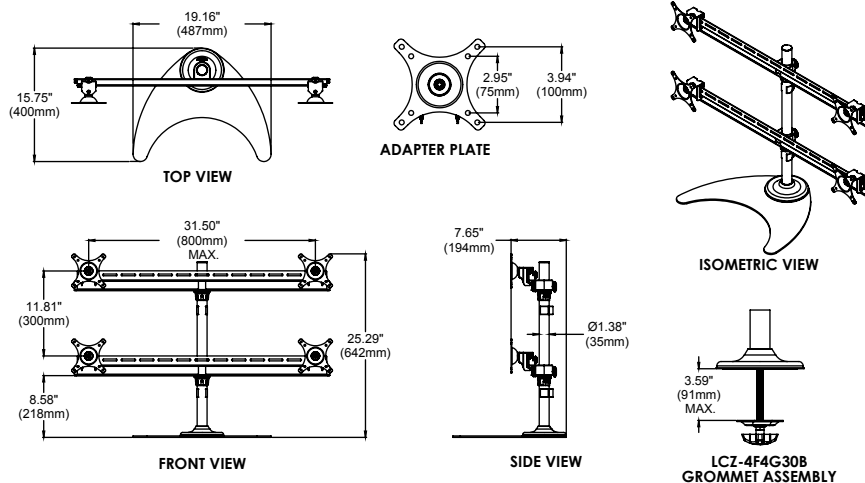

## ACCESSORIES



**PTM200(-S):**  
Universal Tablet Cradle .....pg# 78



**ACC450:**  
VESA® 200 x 200mm Accessory Plate  
Contact Peerless-AV Customer Care for more information.

To verify mount compatibility with any flat panel display or projector model use MountFinder™ at [www.peerless-av.com](http://www.peerless-av.com)



CALL: 630-375-5100  
800-865-2112



FAX: 630-820-8537  
800-359-6500



E-MAIL:  
[info@peerless-av.com](mailto:info@peerless-av.com)



ONLINE:  
[www.peerless-av.com](http://www.peerless-av.com)



# 420-Series Desktop Mount

For 12" to 30" Flat Panel Displays

## MODELS

### Universal Models:

Includes standard hardware (hex or Phillips) for attaching display to mount

<b>LCT420A</b>	Desktop	Black
<b>LCW420A</b>	Wall	Black

## DISPLAY ADAPTER

### VESA® Pattern

Universal Models: 75 and 100mm

## SPECIFICATIONS

### Distance from Base

19.40" (493mm)

### Tilt | Swivel | Roll

+80°/-10° (monitor) ±45° (arm) | 180° | 360°

### Max Load

20lb (9kg)

### Landscape to Portrait

Display can be rotated from landscape to portrait without removing the display.

### Product Dimensions (W x H x D)

<b>LCT420A:</b>	7.00" x 16.00" x 19.40" (178 x 406 x 493mm)
<b>LCW420A:</b>	4.50" x 3.94" x 19.40" (114 x 100 x 493mm)

### Mounting Surfaces

<b>LCT420A:</b>	Desktop
<b>LCW420A:</b>	Wall

### Ship Weight

<b>LCT420A:</b>	10.5lb (4.7kg)
<b>LCW420A:</b>	5.4lb (2.4kg)

## CERTIFICATIONS



## ACCESSORIES



**ACC329:** Laptop Cooling Tray.....pg# 111



**PTM200(-S):** Universal Tablet Cradle .....pg# 78

1. Arm extends up to 16.40" (417mm) with 12.60" (320mm) of height adjustment range on the post
2. Internal cable management routes cables inside the arm
3. Desk clamp and grommet mount option included with desktop model
4. Can be used in laptop configuration
5. Aluminum casted arm provides sturdy and durable support
6. Arm folds back over the base into a compact retracted position



LCT420A

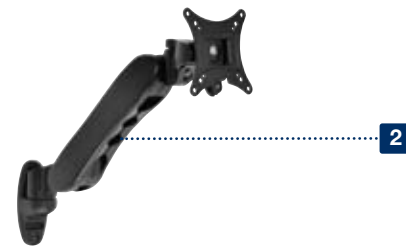

LCW420A

## TECHNICAL DRAWINGS

For expanded product information and technical data visit [www.peerless-av.com](http://www.peerless-av.com)

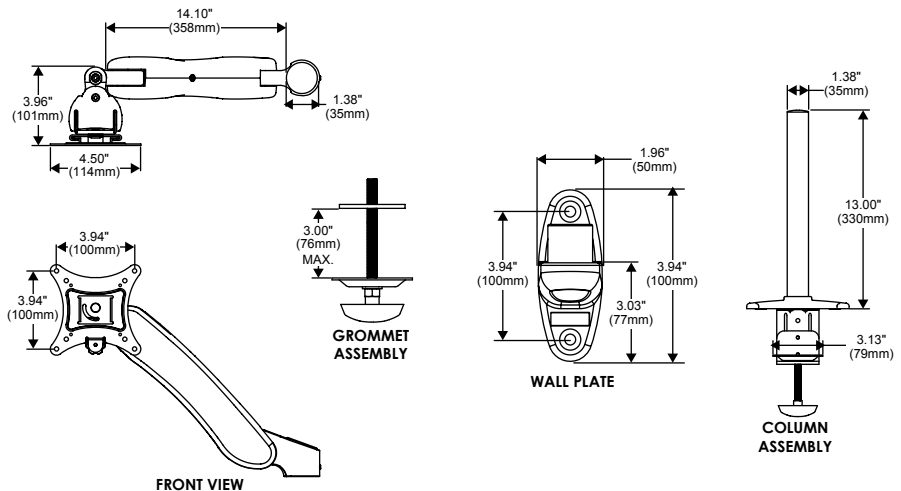

To verify mount compatibility with any flat panel display or projector model use MountFinder™ at [www.peerless-av.com](http://www.peerless-av.com)



# 620-Series Desktop Mount

For 12" to 30" Flat Panel Displays

1. Arm extends up to 23.00" (584mm) with height adjustment range on 12.60" (320mm) post
2. Internal cable management routes cables inside the arm
3. Desk clamp and grommet mount option included with desktop model
4. Can be used in laptop configuration
5. Aluminum casted arm provides sturdy and durable support
6. Arm folds back over the base into a compact retracted position



LCT620A

LCW620A

For expanded product information and technical data visit [www.peerless-av.com](http://www.peerless-av.com)

## TECHNICAL DRAWINGS

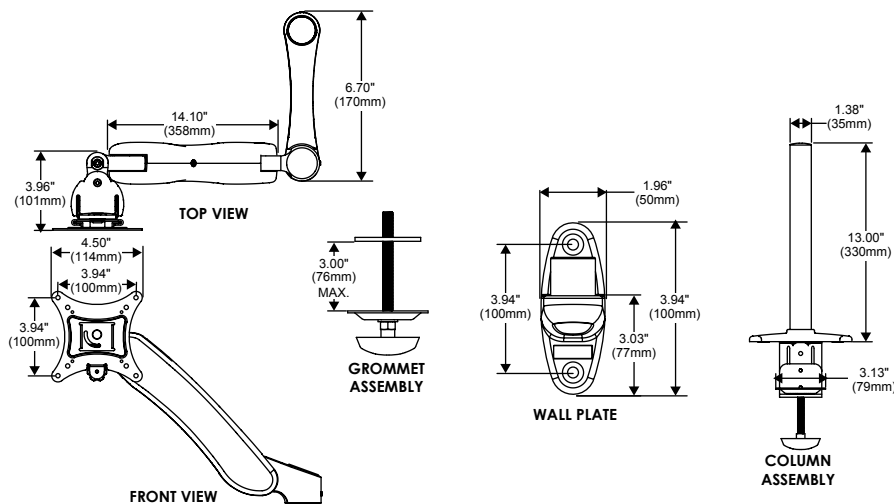

FLAT PANEL MOUNTS

## MODELS

### Universal Models:

Includes standard hardware (hex or Phillips) for attaching display to mount

<b>LCT620A</b>	Desktop	Black
<b>LCW620A</b>	Wall	Black

## DISPLAY ADAPTER



### VESA® Pattern

Universal Models: 75 and 100mm

## SPECIFICATIONS



### Distance from Base

24.76" (629mm)



### Tilt | Swivel | Roll

+80°/-10° (monitor) ±45° (arm) | 180° | 360°



### Max Load

20lb (9kg)



### Landscape to Portrait

Display can be rotated from landscape to portrait without removing the display

### Product Dimensions (W x H x D)

<b>LCT620A:</b>	7.00" x 16.00" x 24.76" (100 x 406 x 629mm)
<b>LCW620A:</b>	4.50" x 3.94" x 24.76" (114 x 100 x 629mm)

### Mounting Surfaces

<b>LCT620A:</b>	Desktop
<b>LCW620A:</b>	Wall

### Ship Weight

<b>LCT620A:</b>	15lb (6.8kg)
<b>LCW620A:</b>	6.9lb (3.1kg)

## CERTIFICATIONS



## ACCESSORIES



**ACC329:**  
Laptop Cooling Tray.....pg# 111



**PTM200(-S):**  
Universal Tablet Cradle .....pg# 78

To verify mount compatibility with any flat panel display or projector model use MountFinder™ at [www.peerless-av.com](http://www.peerless-av.com)



CALL: 630-375-5100  
800-865-2112



FAX: 630-820-8537  
800-359-6500



E-MAIL:  
[info@peerless-av.com](mailto:info@peerless-av.com)



ONLINE:  
[www.peerless-av.com](http://www.peerless-av.com)

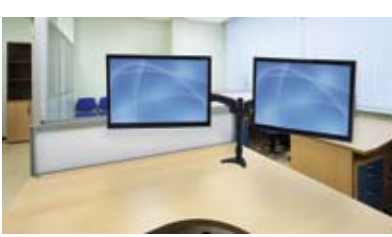

# 620D-Series Desktop Mount

For 12" to 30" Flat Panel Displays

## MODELS

### Universal Models:

Includes standard hardware (hex or Phillips) for attaching display to mount

<b>LCT620AD</b>	Desktop	Black
<b>LCW620AD</b>	Wall	Black

## DISPLAY ADAPTER

### VESA® Pattern

Universal Models: 75 and 100mm

## SPECIFICATIONS

### Distance from Base

24.76" (629mm)

### Tilt | Swivel | Roll

+80°/-10° (monitor) ±45° (arm) | 180° | 360°

### Max Load

40lb (18kg)

### Landscape to Portrait

Display can be rotated from landscape to portrait without removing the display

### Product Dimensions (W x H x D)

<b>LCT620AD:</b>	7.00" x 16.00" x 24.76" (178 x 406 x 629mm)
<b>LCW620AD:</b>	9.00" x 3.94" x 24.76" (228 x 100 x 629mm)

### Mounting Surfaces

<b>LCT620AD:</b>	Desktop
<b>LCW620AD:</b>	Wall

### Ship Weight

<b>LCT620AD:</b>	16.3lb (7.3kg)
<b>LCW620AD:</b>	13lb (5.8kg)

## CERTIFICATIONS



## ACCESSORIES



**ACC329:**  
Laptop Cooling Tray.....pg# 111



**PTM200(-S):**  
Universal Tablet Cradle .....pg# 78

1. Arms extend upto 23.00" (584mm) with height adjustment range of 12.60" (320mm) on the post
2. Internal cable management routes cables inside the arm
3. Desk clamp and grommet mount option included with desktop model
4. Can be used in laptop configuration
5. Aluminum casted arm provides sturdy and durable support
6. Arm folds back over the base into a compact retracted position

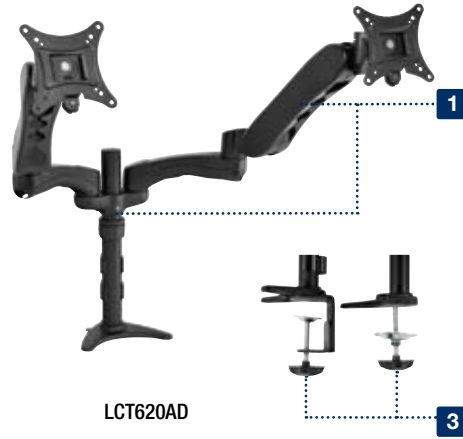

LCT620AD

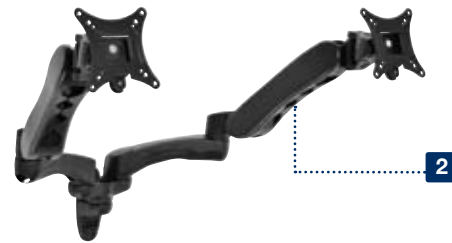

LCW620AD

## TECHNICAL DRAWINGS

For expanded product information and technical data visit [www.peerless-av.com](http://www.peerless-av.com)

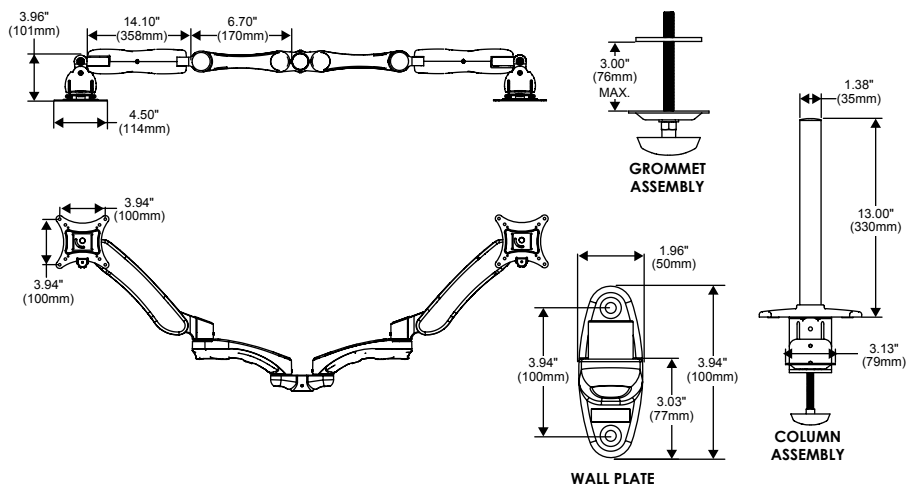

To verify mount compatibility with any flat panel display or projector model use MountFinder™ at [www.peerless-av.com](http://www.peerless-av.com)

# Laptop Cooling Tray

For most Laptop Computers

1. Attaches to any LCT/ LCW420 or 620-series desktop or wall mount
2. Compatible with most laptop computers
3. Offered with a 5 volt cooling fan that plugs into a USB port
4. Easy to attach with included hardware

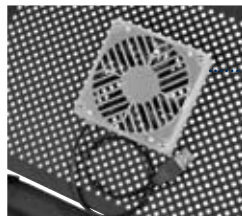

3

For expanded product information and technical data visit [www.peerless-av.com](http://www.peerless-av.com)

## TECHNICAL DRAWINGS

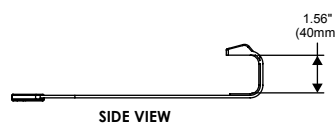
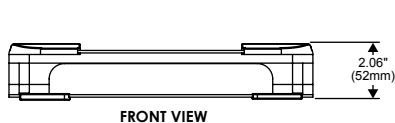
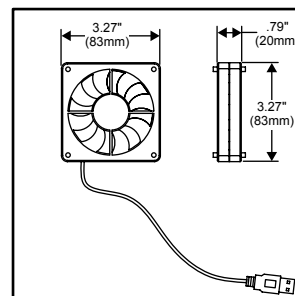
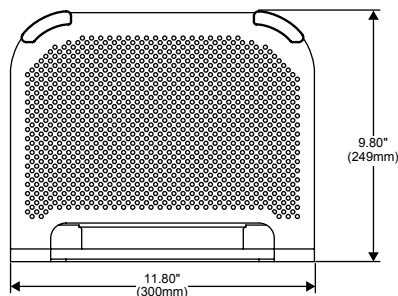

To verify mount compatibility with any flat panel display or projector model use MountFinder™ at [www.peerless-av.com](http://www.peerless-av.com)



CALL: 630-375-5100  
800-865-2112



FAX: 630-820-8537  
800-359-6500



E-MAIL: [info@peerless-av.com](mailto:info@peerless-av.com)



ONLINE: [www.peerless-av.com](http://www.peerless-av.com)

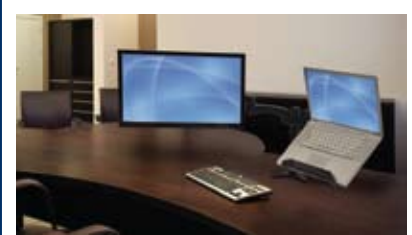

FLAT PANEL MOUNTS

## MODELS

### Universal Models:

Includes standard hardware (hex or Phillips) for attaching display to mount

**ACC329**

Black

## DISPLAY ADAPTER



VESA® Pattern

Universal Models: 75 and 100mm

## SPECIFICATIONS



Max Load

19lb (9kg)

Product Dimensions (W x H x D)

9.80" x 11.80" x 1.90"  
(250 x 300 x 50mm)

Mounting Surfaces

LCT420 and 620-series arms

Ship Weight

2lb (1kg)

## CERTIFICATIONS



## ACCESSORIES



**LCT420A/620A/620AD**  
**LCW420A/620A/620AD:**  
LCT/LCW420/620 series  
desktop or wall mounts.. pg# 108-110



# Floor Cart

For 42" to 58" Flat Panel Displays

## MODELS

### Universal Models:

Includes standard hardware (hex or Phillips) for attaching display to mount

- SC550** Black cart with glass shelf
- SC550GL** Black cart with glass base & shelf

## DISPLAY ADAPTER

### Mounting Pattern

Universal Models: 720 x 400mm  
(28.30"W x 15.70"H)

### VESA® Pattern

Universal Models: Up to 600 x 400mm

## SPECIFICATIONS

### Tilt

+15°/-5°

### Max Load

150lb (68kg)  
125lb (56.7kg) display  
25lb (11kg) shelf

### Product Dimensions (W x H x D)

**SS550:** 34.60" x 70.30" x 25.90"  
(880 x 1786 x 660mm)

**SS550GL:** 39.30" x 70.30" x 19.60"  
(1000 x 1786 x 500mm)

### Mounting Surfaces

All floor surfaces

### Ship Weight

**SS550:** 104lb (47.18kg)  
**SS550GL:** 85lb (38.7kg)

1. Tempered glass base to meet local building codes and safety requirements (SC550GL model)
2. Display tilt adjustment of +15°/-5° for desired viewing angle
3. Independent display height adjustment of 11.8" (300mm)
4. Adjustable tempered glass shelf for AV components and accessories
5. Internal cable management system helps keep cables concealed and organized
6. 2.50" (64mm) swivel casters with two locking to ensure safety and easily maneuverability



## TECHNICAL DRAWINGS

For expanded product information and technical data visit [www.peerless-av.com](http://www.peerless-av.com)

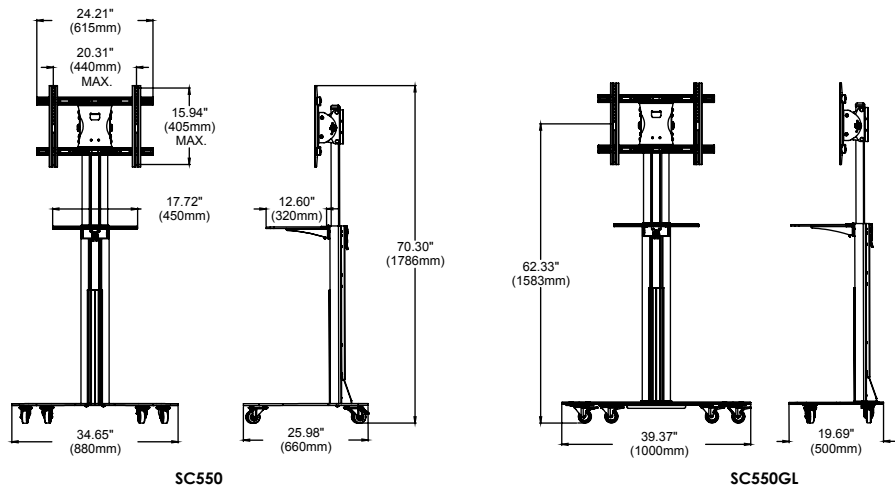

## CERTIFICATIONS



To verify mount compatibility with any flat panel display or projector model use MountFinder™ at [www.peerless-av.com](http://www.peerless-av.com)



CALL: 630-375-5100  
800-865-2112



FAX: 630-820-8537  
800-359-6500



E-MAIL: [info@peerless-av.com](mailto:info@peerless-av.com)



ONLINE: [www.peerless-av.com](http://www.peerless-av.com)

# Floor Cart

For 42" to 55" Flat Panel Displays

1. Compact design offers personalized computing and video conferencing
2. Tempered glass base to meet local building codes and safety requirements
3. Display tilt adjustment of +15°/-5° for desired viewing angle
4. Features effortless telescoping height adjustment without tools
5. Adjustable tempered glass shelf for AV components and accessories
6. Internal cable management system helps keep cables concealed and organized
7. 2.50" (64mm) swivel casters with two locks to ensure safety and easily maneuverability



For expanded product information and technical data visit [www.peerless-av.com](http://www.peerless-av.com)

## TECHNICAL DRAWINGS

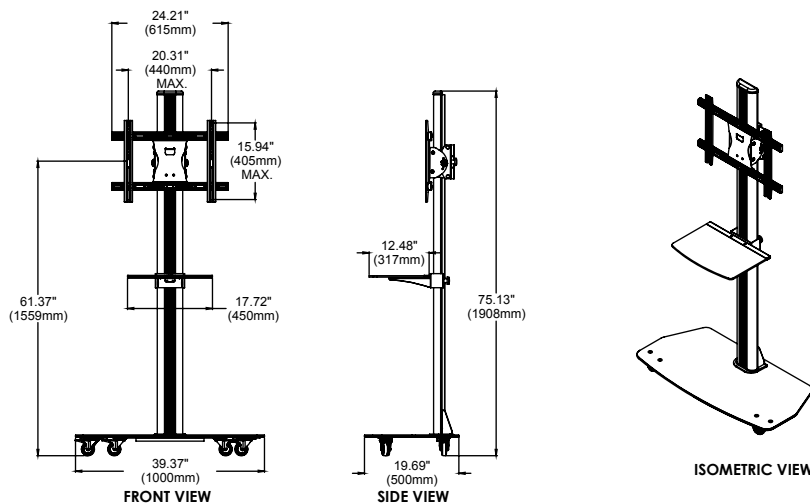

To verify mount compatibility with any flat panel display or projector model use MountFinder™ at [www.peerless-av.com](http://www.peerless-av.com)



CALL: 630-375-5100  
800-865-2112



FAX: 630-820-8537  
800-359-6500



E-MAIL: [info@peerless-av.com](mailto:info@peerless-av.com)



ONLINE: [www.peerless-av.com](http://www.peerless-av.com)



FLAT PANEL MOUNTS

## MODELS

### Universal Models:

Includes standard hardware (hex or Phillips) for attaching display to mount

**SC551GL** Black

## DISPLAY ADAPTER



### Mounting Pattern

Universal Models: 720 x 400mm  
(28.30"W x 15.70"H)



### VESA® Pattern

Universal Models: 200, 200 x 400, 400  
and 600 x 400mm

## SPECIFICATIONS



### Tilt

+15°/-5°



### Max Load

91lb (41kg)  
66lb (30kg) display  
25lb (11kg) shelf

### Product Dimensions (W x H x D)

39.30" x 75.10" x 19.60"  
(1000 x 1908 x 500mm)

### Mounting Surfaces

All floor surfaces

### Ship Weight

95lb (43kg)

## CERTIFICATIONS





# Floor Stand/Cart

For 32" to 65" Flat Panel Displays

## MODELS

### Universal Models:

- Includes theft resistant hardware for attaching display to mount
- SS560M** Black stand with metal shelf
  - SS560G** Black stand with glass shelf
  - SR560M** Black cart with metal shelf
  - SR560G** Black cart with glass shelf

### Dedicated Models:

- Includes theft resistant hardware for attaching display to mount  
Display adapter purchased separately\*
- SR1M** Black cart with metal shelf
  - SR1G** Black cart with glass shelf

\*Dedicated adapter plates come in flat black and include security fasteners

## DISPLAY ADAPTER



### Mounting Pattern

**Universal Models:** 729 x 433mm  
(28.70"W x 17.050"H)



### VESA® Pattern

**Universal Models:** Up to 600 x 400mm  
**Dedicated Models:** Requires display-specific adapter to be purchased separately.

## SPECIFICATIONS



### Tilt

-2°, 0°, +5°



### Max Load

250lb (113kg)  
150lb (68kg) display  
50lb (22kg) shelf

### Product Dimensions (W x H x D)

35.60" x 65.00" x 26.90"  
(904 x 1651 x 683mm)

### Ship Weight

**SS560M / SR560M:** 87.3lb (38.5kg)  
**SS560G / SR560G:** 88.8lb (40.2kg)  
**SR1M:** 76.8lb (34.8kg)  
**SR1G:** 78.3lb (35.5kg)

## CERTIFICATIONS



## ACCESSORIES



**ACC310:** Feet Accessory..... pg# 198



**ACC313:** Metal Shelf..... pg# 198



**ACC314:** Laptop Arm..... pg# 198



**ACC315:** Base Shelf..... pg# 198



**ACC316:** Safety Belt..... pg# 199



**ACC318:** Tempered Glass Shelf..... pg# 198



**ACC319:** Video Conferencing Shelf..... pg# 198



**ACC320:** Electrical Outlet Strip with Cord Wrap..... pg# 199

1. Incremental tilt of -2°, 0° and +5° locks in the ideal viewing angle
2. Continuous vertical adjustment for perfect viewing height
3. Maneuvers easily on 4.00" (102mm) swivel casters, two locking (SR models)
4. Adjustable feet to help compensate for uneven floor surfaces (SS models)
5. Adjustable metal or tempered glass shelf holds AV components and accessories
6. Internal cable management for clean, clutter-free appearance



## TECHNICAL DRAWINGS

For expanded product information and technical data visit [www.peerless-av.com](http://www.peerless-av.com)

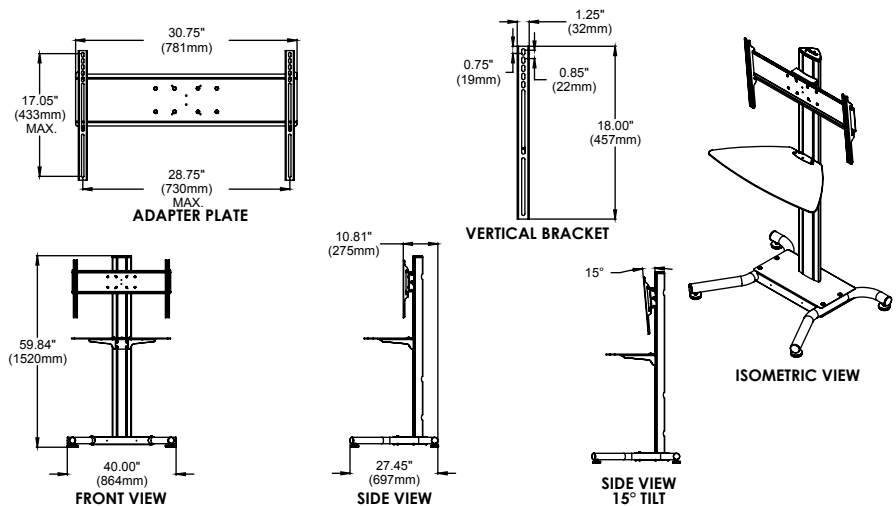







# Floor Stand

For 32" to 65" Flat Panel Displays

## MODELS

### Universal Models:

Includes theft resistant hardware for attaching display to mount  
**SS560F** Black

## DISPLAY ADAPTER



### VESA® Pattern

**Universal Models:** 200 and 300mm  
**Dedicated Models:** Requires display-specific adapter to be purchased separately.

## SPECIFICATIONS



### Tilt

-2°, 0°, +5°



### Max Load

160lb (72.5kg)

### Product Dimensions (W x H x D)

33.50" x 68.30" x 26.50"  
 (851 x 1736 x 673mm)

### Mounting Surfaces

All floor surfaces

### Ship Weight

101.4lb (45.9kg)

## CERTIFICATIONS



## ACCESSORIES



**ACC313:** Metal Shelf ..... pg# 198



**ACC318:** Tempered Glass Shelf ..... pg# 198



**PLP-UNL:** Universal Adapter Plate  
 Contact Peerless-AV Customer Care for more information.

## TECHNICAL DRAWINGS

For expanded product information and technical data visit [www.peerless-av.com](http://www.peerless-av.com)

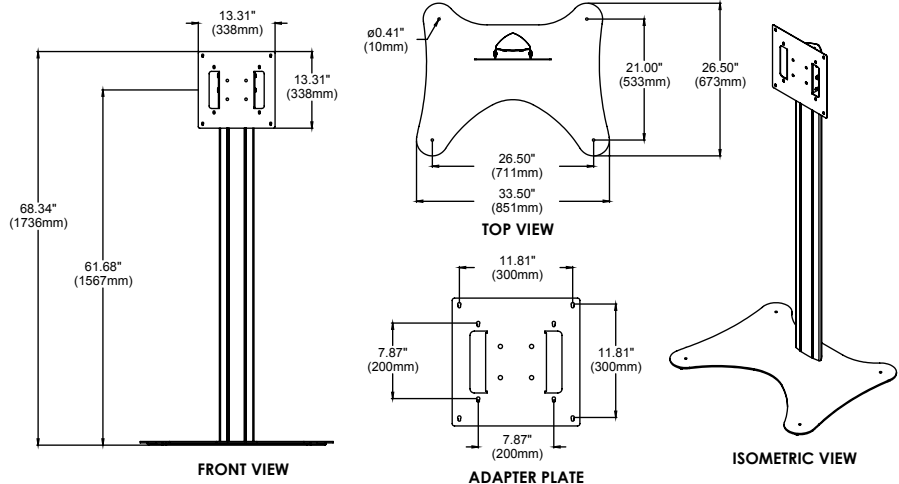

1. Incremental tilt of -2°, 0° and +5° provides ideal viewing angle
2. Continuous vertical adjustment for perfect viewing height
3. Internal cable management for clean, clutter free appearance



# Floor Stand

For 32" to 65" Flat Panel Displays

1. Chrome or black posts to match the décor of any room or space
2. Incremental tilt of -2°, 0°, and +5° and locks in the ideal viewing angle
3. Continuous vertical adjustment for perfect viewing height
4. Internal cable management for clean, clutter free appearance



SS560DPS

For expanded product information and technical data visit [www.peerless-av.com](http://www.peerless-av.com)

## TECHNICAL DRAWINGS

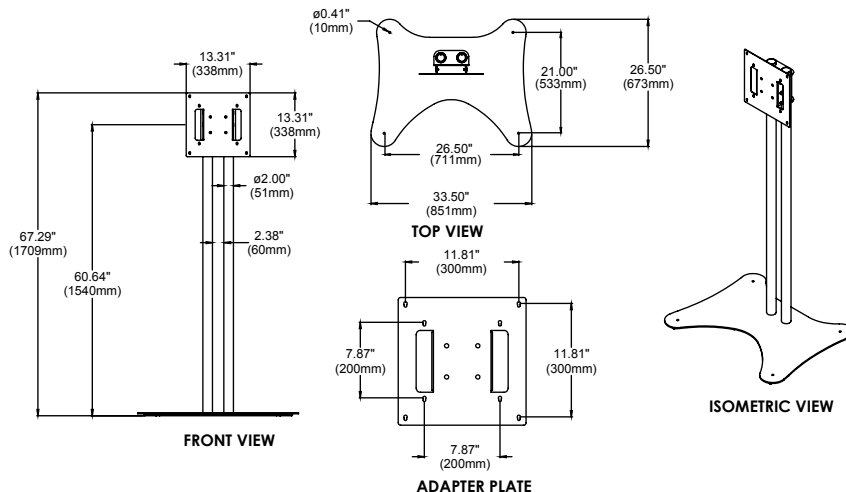

To verify mount compatibility with any flat panel display or projector model use MountFinder™ at [www.peerless-av.com](http://www.peerless-av.com)



CALL: 630-375-5100  
800-865-2112



FAX: 630-820-8537  
800-359-6500



E-MAIL: [info@peerless-av.com](mailto:info@peerless-av.com)



ONLINE: [www.peerless-av.com](http://www.peerless-av.com)



FLAT PANEL MOUNTS

## MODELS

### Universal Models:

Includes theft resistant hardware for attaching display to mount

**SS560DPB** Black  
**SS560DPS** Black and chrome

## DISPLAY ADAPTER



### VESA® Pattern

Universal Models: 200 and 300mm

Dedicated Models: Requires display-specific adapter to be purchased separately.

## SPECIFICATIONS



### Tilt

-2°, 0°, +5°



### Max Load

160lb (72.5kg)

### Product Dimensions (W x H x D)

33.50" x 67.00" x 26.50"  
(851 x 1709 x 673mm)

### Mounting Surfaces

All floor surfaces

### Ship Weight

113lb (51.2kg)

## CERTIFICATIONS



Pending



## ACCESSORIES



**ACC604:**  
Dual-Display Cartridge .....pg# 195



**ACC325:**  
Accessory Shelf .....pg# 198



**PLP-UNL:**  
Universal Adapter Plate  
Contact Peerless-AV Customer Care for more information.



# Floor Stand

For 32" to 70" Flat Panel Displays

## MODELS

### Universal Models:

Display adapter purchased separately for non-VESA® displays\*  
Includes theft resistant hardware for attaching display to mount

**FPZ-600** Black

\* Dedicated adapter plates come in flat black and include security fasteners

## DISPLAY ADAPTER



### VESA® Pattern

**Universal Models:** 100, 200 x 100  
and 200 x 200mm

**Dedicated Models:** Non-VESA® compatible displays  
require display-specific adapter to  
be purchased separately.

## SPECIFICATIONS



### Height Adjustment

On 72" (1829mm) poles



### Max Load

200lb (90kg) per display  
up to four displays

### Product Dimensions (W x H x D)

28.75" x 72.00" x 36.00"  
(730 x 1829 x 914mm)

### Mounting Surfaces

All floor surfaces



### Ship Weight

**Box 1:** 82.9lb (37.6kg)  
**Box 2:** 17.6lb (7.9kg)  
**Box 3:** 17.6lb (7.9kg)

## CERTIFICATIONS



## ACCESSORIES



**ACC604:**  
Dual-Display Cartridge .....pg# 195



**ACC325:**  
Accessory Shelf .....pg# 198



**PLP-UNL:**  
Universal Adapter Plate  
Contact Peerless-AV Customer Care  
for more information.

1. VESA® 100, 200 x 100 and 200 x 200mm compliant
2. Supports non-VESA® displays with additional PLP display adapter (sold separately)
3. Fits single or back-to-back 32" to 70" flat panel displays (up to four with additional dual-display cartridge)
4. Portrait or landscape orientation
5. Internal cable management for a clean, clutter-free appearance
6. Height adjustable on 72" (1829mm) poles



## TECHNICAL DRAWINGS

For expanded product information and technical data visit [www.peerless-av.com](http://www.peerless-av.com)

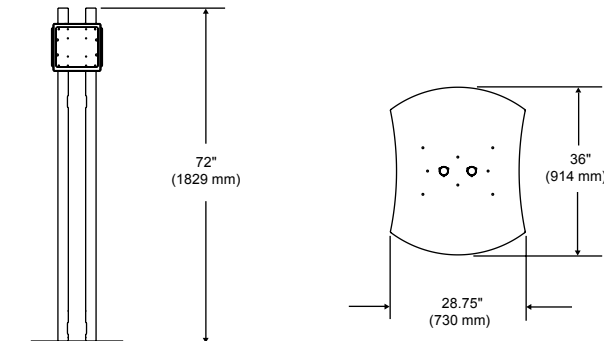

To verify mount compatibility with any flat panel display or projector model use MountFinder™ at [www.peerless-av.com](http://www.peerless-av.com)



**CALL:** 630-375-5100  
800-865-2112



**FAX:** 630-820-8537  
800-359-6500



**E-MAIL:**  
[info@peerless-av.com](mailto:info@peerless-av.com)



**ONLINE:**  
[www.peerless-av.com](http://www.peerless-av.com)

# Floor Stand

For 50" to 71" Flat Panel Displays

1. VESA® 100, 200 x 100 and 200 x 200mm compliant
2. Supports non-VESA® displays with additional PLP display adapter (sold separately)
3. Internal cable management to easily route cables from the display to the base of the stand
4. Base cover is designed to conceal content drivers and surge protector
5. Hook-on design allows display to rest in place while display is being secured
6. Portrait or landscape orientation



For expanded product information and technical data visit [www.peerless-av.com](http://www.peerless-av.com)

## TECHNICAL DRAWINGS

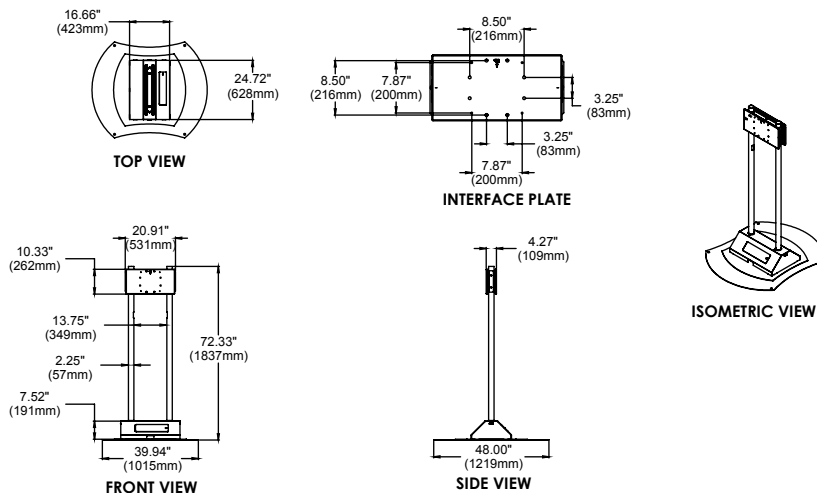

To verify mount compatibility with any flat panel display or projector model use MountFinder™ at [www.peerless-av.com](http://www.peerless-av.com)



**CALL:** 630-375-5100  
800-865-2112



**FAX:** 630-820-8537  
800-359-6500



**E-MAIL:**  
[info@peerless-av.com](mailto:info@peerless-av.com)



**ONLINE:**  
[www.peerless-av.com](http://www.peerless-av.com)



FLAT PANEL MOUNTS

## MODELS

### Universal Models:

Display adapter purchased separately for non-VESA® displays\* Includes theft resistant hardware for attaching display to mount  
**FPZ-670** Black

\*Dedicated adapter plates come in flat black and include security fasteners

## DISPLAY ADAPTER



### VESA® Pattern

**Universal Models:** 100, 200 x 100 and 200 x 200mm

**Dedicated Models:** Non-VESA® compatible displays require display-specific adapter to be purchased separately.

## SPECIFICATIONS



### Height Adjustment

On 6' (1829mm) poles



### Max Load

400lb (181.4kg) total  
200lb (90kg) per display  
up to two displays

### Product Dimensions (W x H x D)

39.87" x 72.30" x 48.00"  
(1013 x 1836 x 1219mm)

### Mounting Surfaces

All floor surfaces



### Ship Weight

**Box 1:** 165lb (74.8kg)  
**Box 2:** 17.6lb (7.9kg)  
**Box 3:** 17.6lb (7.9kg)

## CERTIFICATIONS



Pending



## ACCESSORIES



### MIS735:

Dual-Display Cartridge .....pg# 195



### Universal Adapter Plate

Contact Peerless-AV Customer Care for more information.



# Floor Stand/Cart

For 32" to 65" Flat Panel Displays

## MODELS

### Universal Models:

Includes theft resistant hardware for attaching display to mount

<b>SS560FK</b>	Stand	Black
<b>SC560FK</b>	Cart	Black

## DISPLAY ADAPTER



### Mounting Pattern

Universal Models: 729 x 433mm  
(28.70"W x 17.00"H)



### VESA® Pattern

Universal Models: Up to 600 and 400mm  
Dedicated Models: Requires display-specific adapter to be purchased separately.

## SPECIFICATIONS



### Tilt

0°, +30°



### Max Load

150lb (68kg)

### Product Dimensions (W x H x D)

<b>SS560FK:</b>	33.50" x 45.40" x 26.50" (851 x 1155 x 673mm)
<b>SC560FK:</b>	33.90" x 40.00" x 27.40" (852 x 1016 x 697mm)

### Ship Weight

85lb (38.5kg)

## CERTIFICATIONS



## ACCESSORIES



**ACC313:**  
Metal Shelf..... pg# 198

1. Stylish 3.25" (83mm) triangular aluminum column
2. Capable of 30° tilt for the perfect viewing angle
3. Space below display for a computer or media box storage and allows access to the media device without having to remove the display
4. Internal cable management for clean, clutter free appearance
5. Maneuvers easily on 4.00" (102mm) swivel casters, with 2 of them locking (SC560FK)



SS560FK



SC560FK

## TECHNICAL DRAWINGS

For expanded product information and technical data visit [www.peerless-av.com](http://www.peerless-av.com)

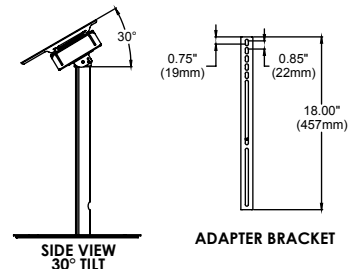
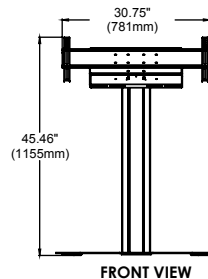
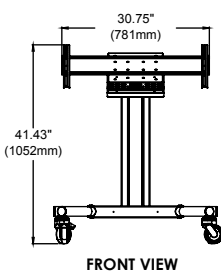
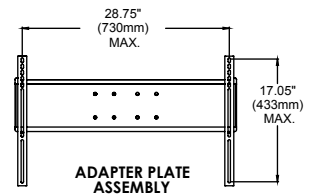
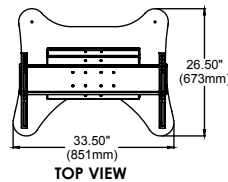
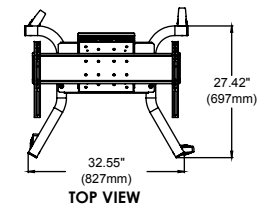

To verify mount compatibility with any flat panel display or projector model use MountFinder™ at [www.peerless-av.com](http://www.peerless-av.com)



CALL: 630-375-5100  
800-865-2112



FAX: 630-820-8537  
800-359-6500



E-MAIL: [info@peerless-av.com](mailto:info@peerless-av.com)



ONLINE: [www.peerless-av.com](http://www.peerless-av.com)



# Floor Stand

For 32" to 65" Flat Panel Displays

1. Designed to complement the look of any room with its modern colors and stylish design
2. Incremental tilt of -2°, 0° and +5° provides ideal viewing angle
3. Continuous vertical adjustment for perfect viewing height
4. Adjustable tempered glass shelves to hold AV components and accessories (additional shelf available)
5. Internal cable management neatly hides all cables for a clean, clutter-free appearance

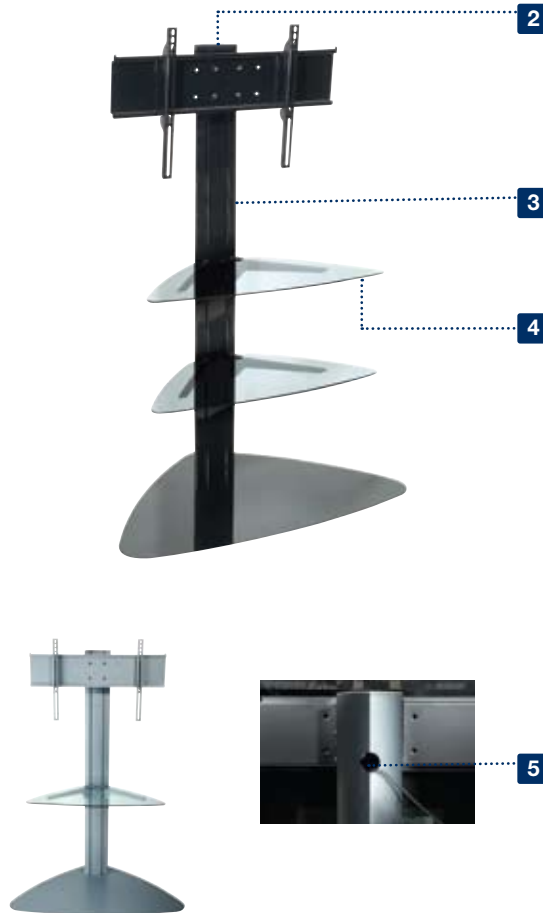

For expanded product information and technical data visit [www.peerless-av.com](http://www.peerless-av.com)

## TECHNICAL DRAWINGS

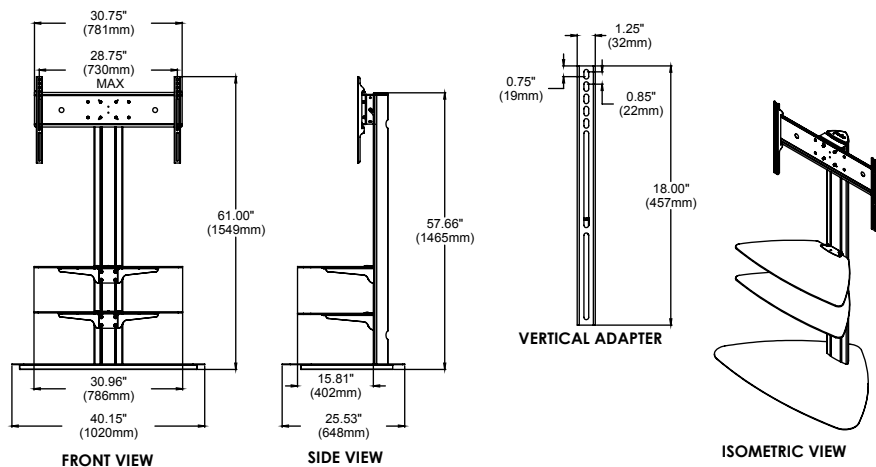

To verify mount compatibility with any flat panel display or projector model use MountFinder™ at [www.peerless-av.com](http://www.peerless-av.com)



CALL: 630-375-5100  
800-865-2112



FAX: 630-820-8537  
800-359-6500



E-MAIL: [info@peerless-av.com](mailto:info@peerless-av.com)



ONLINE: [www.peerless-av.com](http://www.peerless-av.com)



FLAT PANEL MOUNTS

## MODELS

### Universal Models:

Includes standard hardware (hex or Phillips) for attaching display to mount

<b>SS550P</b>	High gloss black with 2 tinted shelves
<b>SS550P-S</b>	Silver with 2 tinted shelves
<b>SGLB01</b>	Black with 1 clear shelf
<b>SGLS01</b>	Silver with 1 clear shelf

## DISPLAY ADAPTER



### Mounting Pattern

Universal Models: 729 x 433mm  
(28.70"W x 17.05"H)



### VESA® Pattern

Universal Models: Up to 600 x 400mm

## SPECIFICATIONS



### Tilt

-2°, 0°, +5°



### Max Load

250lb (113kg)  
150lb (68kg) display  
50lb (22kg) per shelf

### Product Dimensions (W x H x D)

40.15" x 57.63" x 25.53"  
(1020 x 1464 x 648mm)

### Mounting Surfaces

All floor surfaces

### Ship Weight

SS models: 95lb (43.1kg)  
SGL models: 85lb (38.5kg)

## CERTIFICATIONS



SGL models: **Quickship Item**

## ACCESSORIES

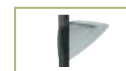

Tempered Glass Shelf .....pg# 198  
**ACC317:** Clear glass, black bracket  
**ACC317-S:** Clear glass, silver bracket  
**ACC318:** Tinted glass, black bracket  
**ACC318-S:** Tinted glass, silver bracket  
**ACC318-GB:** Tinted glass, high gloss black bracket



# Floor Stand

For up to 52" Flat Panel Displays

## MODELS

### Universal Models:

Includes standard hardware (hex or Phillips) for attaching display to mount

**FPZ-640** Black

## DISPLAY ADAPTER

### VESA® Pattern

Universal Models: 75, 100, 200 x 100 and 200 x 200mm

## SPECIFICATIONS

### Height Adjustment

48.55"-64.29" (1233-1633mm)



### Swivel

360°



### Max Load

110 lb (49 kg)

### Product Dimensions (W x H x D)

54.07" x 48.55"-64.29" x 54.07"  
(1373 x 1233-1633 x 1373mm)

### Mounting Surfaces

All floor surfaces

## CERTIFICATIONS

**RoHS**

## ACCESSORIES



**ACC330:**  
AV component Shelf .....pg# 198



**ACC332:**  
Casters .....pg# 198



**PLP-UNL:**  
Universal Adapter Plate  
Contact Peerless-AV Customer Care for more information.

1. VESA® 75, 100, 200 x 100 and 200 x 200mm compliant
2. Collapsible design allows legs to fold for easy transporting and storing
3. Integrated cable management to simply route cables through column
4. Height adjustability in 1" (25mm) increments for ideal height of display; Ranges from 48.55"-64.29" (1233-1633mm)



## TECHNICAL DRAWINGS

For expanded product information and technical data visit [www.peerless-av.com](http://www.peerless-av.com)

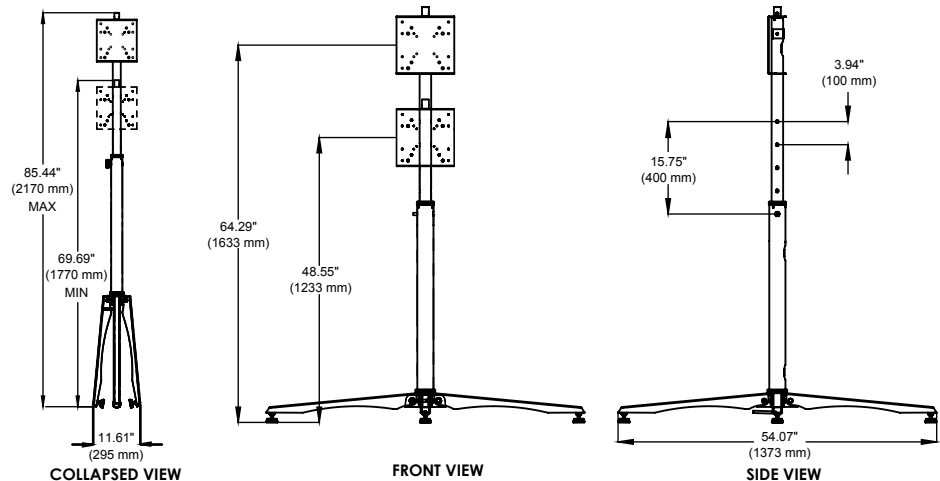

To verify mount compatibility with any flat panel display or projector model use MountFinder™ at [www.peerless-av.com](http://www.peerless-av.com)



CALL: 630-375-5100  
800-865-2112



FAX: 630-820-8537  
800-359-6500



E-MAIL:  
[info@peerless-av.com](mailto:info@peerless-av.com)



ONLINE:  
[www.peerless-av.com](http://www.peerless-av.com)

# Floor Stand

For 32" to 55" Flat Panel Displays

1. Adjustable display positioning along the height of the stand
2. Set the perfect viewing angle with 360° swivel
3. Built-in cable management provides a clean look in any application
4. Tinted tempered glass shelf with 11.50" (292mm) of height adjustability along the height of the stand
5. 8" (203mm) of display height adjustability

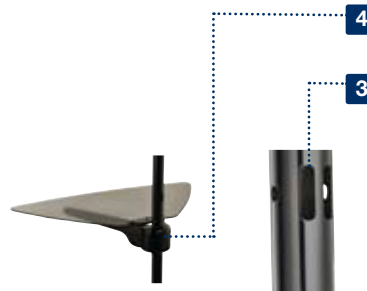

For expanded product information and technical data visit [www.peerless-av.com](http://www.peerless-av.com)

## TECHNICAL DRAWINGS

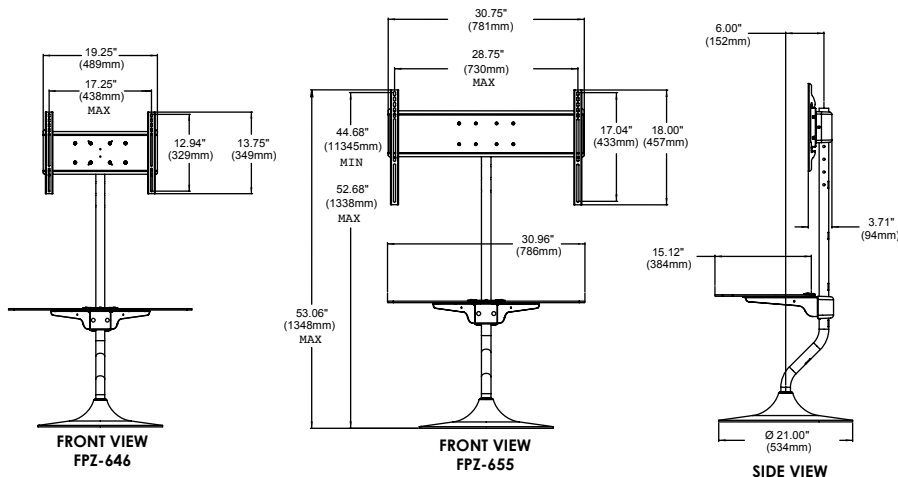

To verify mount compatibility with any flat panel display or projector model use MountFinder™ at [www.peerless-av.com](http://www.peerless-av.com)



CALL: 630-375-5100  
800-865-2112



FAX: 630-820-8537  
800-359-6500



E-MAIL: [info@peerless-av.com](mailto:info@peerless-av.com)



ONLINE: [www.peerless-av.com](http://www.peerless-av.com)



FLAT PANEL MOUNTS

## MODELS

### Universal Models:

Includes standard hardware (hex or Phillips) for attaching display to mount

<b>FPZ-646</b>	For 32" - 46" displays	Black
<b>FPZ-655</b>	For 37" - 55" displays	Black

## DISPLAY ADAPTER



### Mounting Pattern

#### Universal Models:

**FPZ-646:** 438 x 329mm  
(17.25"W x 12.94"H)

**FPZ-655:** 730 x 433mm  
(28.75"W x 17.04"H)



### VESA® Pattern

#### Universal Models:

**FPZ-646:** Up to 400 x 300mm  
**FPZ-655:** Up to 600 x 400mm

**Dedicated Models:** Requires display-specific adapter to be purchased separately.

## SPECIFICATIONS



### Max Load

100lb (45kg)

### Product Dimensions (W x H x D)

30.80" x 53.00" x 21.00"  
(782 x 1346 x 533mm)

### Mounting Surfaces

All floor surfaces

### Ship Weight

**FPZ-646:** 37lb (16.8kg)  
**FPZ-655:** 42.5lb (19.3kg)

## CERTIFICATIONS





# Pedestal Mount

## For 32" to 50" Flat Panel Displays

### MODELS

#### Dedicated Models:

Display adapter purchased separately\*  
Includes theft resistant hardware for attaching display to mount

<b>COL510P</b>	5 feet	Black
<b>COL610P</b>	6 feet	Black
<b>COL710P</b>	7 feet	Black
<b>COL810P</b>	8 feet	Black

\*Dedicated adapter plates come in flat black and include security fasteners

### DISPLAY ADAPTER

**Dedicated Models:** Require display-specific adapter to be purchased separately

### SPECIFICATIONS

#### Tilt | Swivel

+15°, 360°

#### Max load

150lb (68kg)

#### Product Dimensions (W x H x D)

<b>COL510P:</b>	15" x 68.15" x 14.48" (381 x 1731 x 368mm)
<b>COL610P:</b>	15" x 80.15" x 14.48" (381 x 2036 x 368mm)
<b>COL710P:</b>	15" x 92.15" x 14.48" (381 x 2341 x 368mm)
<b>COL810P:</b>	15" x 104.15" x 14.48" (381 x 2645 x 368mm)

#### Mounting Surfaces

Concrete

#### Ship Weight

<b>COL510P:</b>	<b>Box 1:</b>	16.40lb (7.42kg)
	<b>Box 2:</b>	25.20lb (11.44kg)
<b>COL610P:</b>	<b>Box 1:</b>	19.15lb (8.65kg)
	<b>Box 2:</b>	25.20lb (11.44kg)
<b>COL710P:</b>	<b>Box 1:</b>	23.25lb (11.50kg)
	<b>Box 2:</b>	25.20lb (11.44kg)
<b>COL810P:</b>	<b>Box 1:</b>	26.15lb (11.86kg)
	<b>Box 2:</b>	25.20lb (11.44kg)

### CERTIFICATIONS



### ACCESSORIES



**ACC833:**  
Equipment Accessory Shelf pg# 198



**PLP-UNL:**  
Universal Adapter Plate  
Contact Peerless-AV Customer Care for more information

1. Choice of 5', 6', 7' or 8' pedestal height
2. 15° forward tilt for viewing flexibility
3. 360° swivel with swivel stop
4. Display can be changed from landscape to portrait orientation without removing the display
5. Internal cable management
6. Concrete floor anchors included



### TECHNICAL DRAWINGS

For expanded product information and technical data visit [www.peerless-av.com](http://www.peerless-av.com)

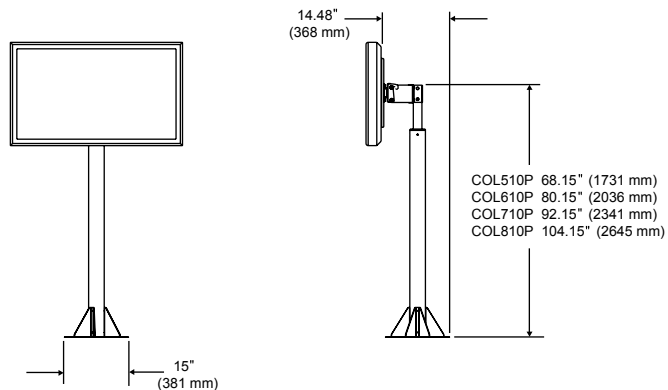

To verify mount compatibility with any flat panel display or projector model use MountFinder™ at [www.peerless-av.com](http://www.peerless-av.com)



**CALL:** 630-375-5100  
800-865-2112



**FAX:** 630-820-8537  
800-359-6500



**E-MAIL:**  
[info@peerless-av.com](mailto:info@peerless-av.com)



**ONLINE:**  
[www.peerless-av.com](http://www.peerless-av.com)

# Pedestal Stand

For 10" to 30" Flat Panel Displays

1. VESA® 75 and 100mm compliant
2. Adjustable height from 60.75" to 80.00" (1543-2032mm)
3. Feet can move inward along pole if required
4. 180° of swivel at the head (up to 90° on each side)
5. Can be used freestanding up to 25lb (11kg) or bolted down up to 40lb (18kg)
6. Comes with hardware to bolt to concrete flooring



For expanded product information and technical data visit [www.peerless-av.com](http://www.peerless-av.com)

## TECHNICAL DRAWINGS

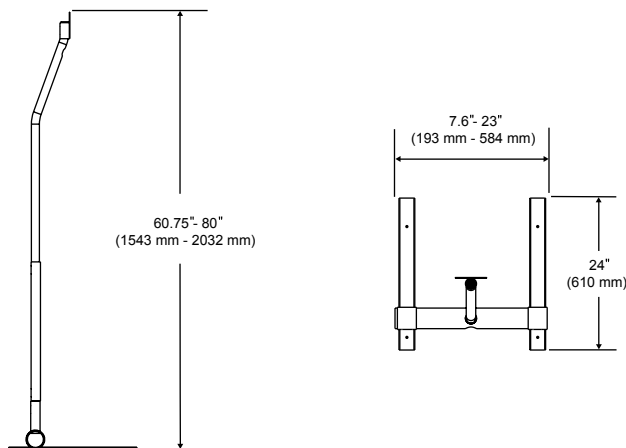

To verify mount compatibility with any flat panel display or projector model use MountFinder™ at [www.peerless-av.com](http://www.peerless-av.com)



CALL: 630-375-5100  
800-865-2112



FAX: 630-820-8537  
800-359-6500



E-MAIL:  
[info@peerless-av.com](mailto:info@peerless-av.com)



ONLINE:  
[www.peerless-av.com](http://www.peerless-av.com)



FLAT PANEL MOUNTS

## MODELS

### Universal Models:

Includes standard hardware (hex or Phillips) for attaching display to mount

**LCFS-100** Black  
**LCFS-100S** Silver

## DISPLAY ADAPTER



### VESA® Pattern

Universal Models: 75 and 100mm

## SPECIFICATIONS



### Height Adjustment

60.75"-80.00" (1543-2032mm)



### Swivel

±90°



### Max Load

**Freestanding:** 25lb (11kg)  
**Bolted down:** 40lb (18kg)

### Product Dimensions (W x H x D)

7.60"-23.00" x 60.75"-80.00"  
x 24.00"  
(193-584 x 1543-2032 x 610mm)

### Mounting Surfaces

All floor surfaces

### Ship Weight

26 lb (11.8kg)

## CERTIFICATIONS



EN 60065

**RoHS**  
2002/95/EC

**MADE IN USA**



# Outdoor Universal Tilt Wall Mount

For 32" to 55" Flat Panel Displays

## MODELS

### Universal Models:

Includes theft resistant hardware and padlock holes (Padlock not supplied)

**EPT650** Black  
**EPT650-S** Stone Gray

## DISPLAY ADAPTER

### Mounting Pattern

Universal Models: 738 x 449mm  
(29.04"W x 17.67"H)

### VESA® Pattern

Universal Models: Up to 600 x 400mm

## SPECIFICATIONS

### Distance from Wall

2.58" (66mm)

### Tilt

+15/-5°

### Max Load

175lb (79kg)

### Product Dimensions (W x H x D)

30.75" x 18.50" x 2.58"  
(781 x 470 x 66mm)

### Mounting Surfaces

Wood, concrete or cinder block

### Ship Weight

10.5lb (5kg)

- Made of corrosion resistant materials for weather resistance
- One touch tilt allows adjustment of +15/-5° with optional tilt lock in 5° increments
- Wall plate knockouts provide additional wall access for improved power and cable management
- Horizontal screen adjustment up to 8" (203mm) for better display placement
- Universal display adapters easily hook onto wall plate for a quick installation
- Easy-glide design ensures display is properly attached to the wall plate



Patented

## CERTIFICATIONS



## TECHNICAL DRAWINGS

For expanded product information and technical data visit [www.peerless-av.com](http://www.peerless-av.com)

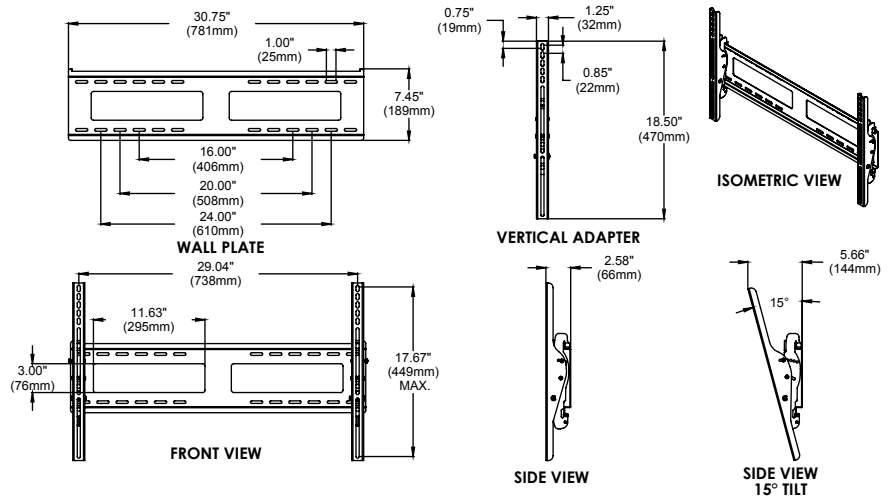

To verify mount compatibility with any flat panel display or projector model use MountFinder™ at [www.peerless-av.com](http://www.peerless-av.com)



# Outdoor Articulating Wall Arm

For 26" to 46" Indoor or Outdoor Flat Panel Displays

- Made of corrosion resistant materials for weather resistance
- Compatibility with displays with up to a VESA® 400 x 400mm mounting hole pattern
- 20.92" (531mm) arm extension when collapsed 4.34" (110mm) from the wall
- Double stud mounting option with 2" (51mm) of horizontal adjustment
- Three adjustable pivot points for versatile display positioning
- ±5° roll aide in post installation display leveling
- Integrated cable management keeps cables out of the way

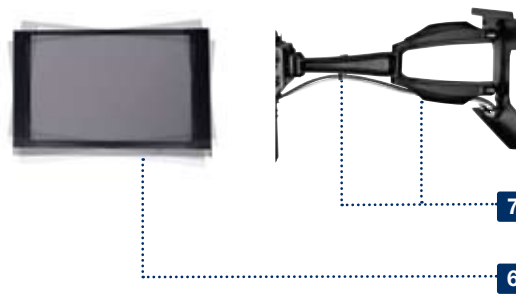
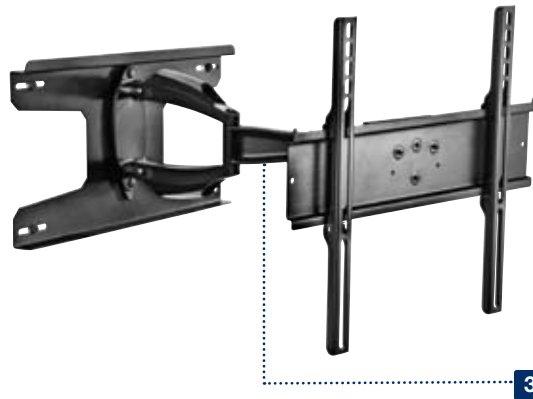

Patented

For expanded product information and technical data visit [www.peerless-av.com](http://www.peerless-av.com)

## TECHNICAL DRAWINGS

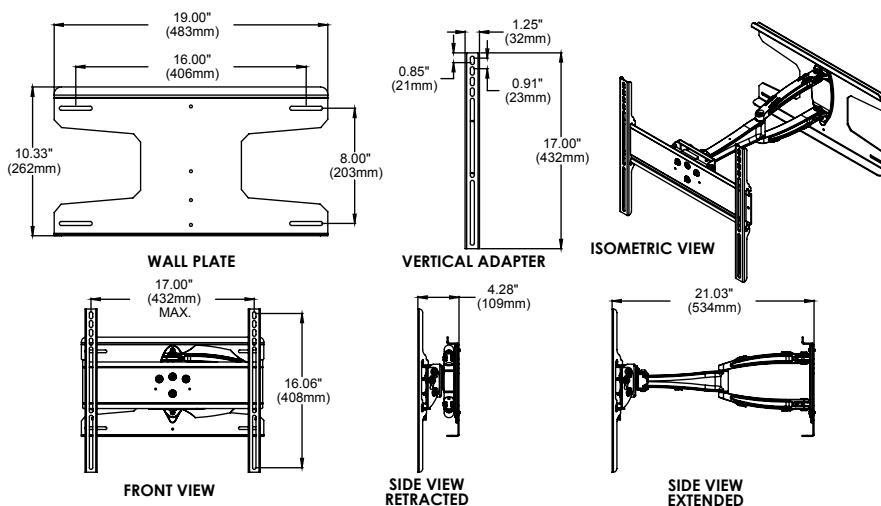

To verify mount compatibility with any flat panel display or projector model use MountFinder™ at [www.peerless-av.com](http://www.peerless-av.com)



CALL: 630-375-5100  
800-865-2112



FAX: 630-820-8537  
800-359-6500



E-MAIL: [info@peerless-av.com](mailto:info@peerless-av.com)



ONLINE: [www.peerless-av.com](http://www.peerless-av.com)



FLAT PANEL MOUNTS

## MODELS

### Universal Models:

Includes theft resistant hardware for attaching display to wall

**ESA746PU** Black  
**ESA746PU-S** Gray

## DISPLAY ADAPTER



### Mounting Pattern

Universal Models: 432 x 408mm  
(17"W x 16.06"H)



### VESA® Pattern

Universal Models: Up to 400 x 400mm

## SPECIFICATIONS



### Distance from Wall

4.28"-21.03" (109-534mm)



### Tilt | Swivel | Roll

+15/-5° | ±90° | ±5°



### Max Load

80lb (36kg)

### Product Dimensions

(W x H x D)  
 18.75" x 17.00" x 4.34"-20.92"  
 (476 x 432 x 110-531mm)

### Mounting Surfaces

Wood stud, concrete and cinder block

### Ship Weight

11lb (5kg)

## CERTIFICATIONS





# Outdoor Articulating Wall Arm

For 37" to 63" Indoor or Outdoor Flat Panel Displays

## MODELS

### Universal Models:

Includes theft resistant hardware for attaching display to mount  
**ESA763PU** Black

## DISPLAY ADAPTER

### Mounting Pattern

Universal Models: 687 x 439mm  
 (27.06"W x 17.29"H)

### VESA® Pattern

Universal Models: Up to 600 x 400mm

## SPECIFICATIONS

### Distance from Wall

Universal Models: 4.43"-27.55" (113-700mm)

### Tilt | Swivel | Roll

+15/-5° | ±90° | ±5°

### Max Load

200lb (91kg)

### Landscape to Portrait

Display can be rotated from landscape to portrait without removing the display.

### Product Dimensions (W x H x D)

Universal Models: 28.68" x 20.23" x 4.43"-27.55"  
 (728 x 514 x 113-700mm)

### Mounting Surfaces

Wood stud, concrete and cinder block

### Ship Weight

Universal Models: 55lb (25kg)

## CERTIFICATIONS



- Made of corrosion resistant materials for weather resistance
- Dual arm construction for added strength and smooth motion on larger displays
- 27.55" (700mm) arm extension when collapsed 4.34" (110mm) from the wall
- Minimalistic wall plate footprint for increased wall access and improved aesthetic
- Integrated cable management provides ample area to run cables to complete a professional and discrete installation
- One-touch tilt allows adjustment of +15°/-5° without the use of tools
- ±5° roll aid in display leveling
- Display can be rotated from landscape to portrait without removing the display



Patented

## TECHNICAL DRAWINGS

For expanded product information and technical data visit [www.peerless-av.com](http://www.peerless-av.com)

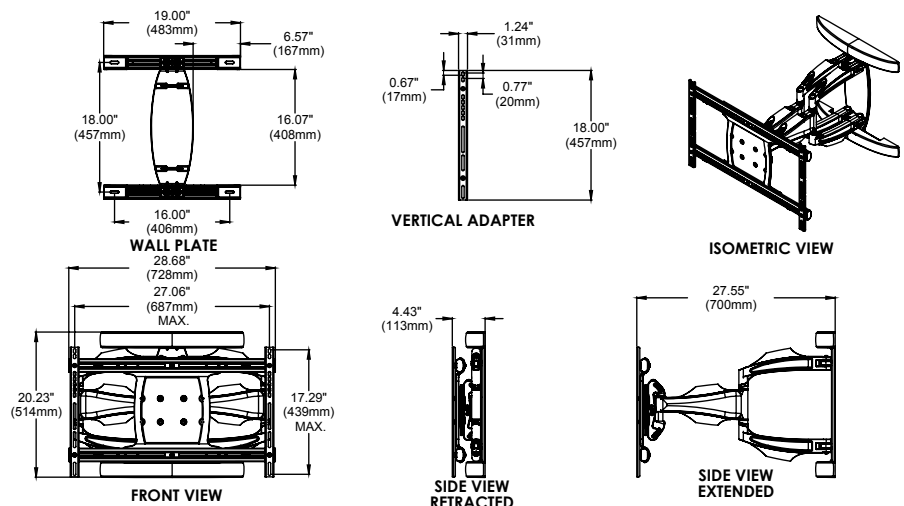

To verify mount compatibility with any flat panel display or projector model use MountFinder™ at [www.peerless-av.com](http://www.peerless-av.com)



CALL: 630-375-5100  
800-865-2112



FAX: 630-820-8537  
800-359-6500



E-MAIL: [info@peerless-av.com](mailto:info@peerless-av.com)



ONLINE: [www.peerless-av.com](http://www.peerless-av.com)

# Indoor/Outdoor Protective Enclosures

For 40" to 55" Flat Panel Displays



FLAT PANEL MOUNTS

- Gas struts deliver easy access to display for installation and maintenance
- 6 outlet 115V 15A power strip provides power to internal components
- Circulation fans ensure proper airflow within the unit
- Rubber gasket seal protects from ingress of water and other harmful elements
- Includes Peerless-AV Universal Flat Panel Mount PF660 that accommodates flat panel displays with up to 600 x 400mm VESA® mounting pattern
- Tested to IP56 standards

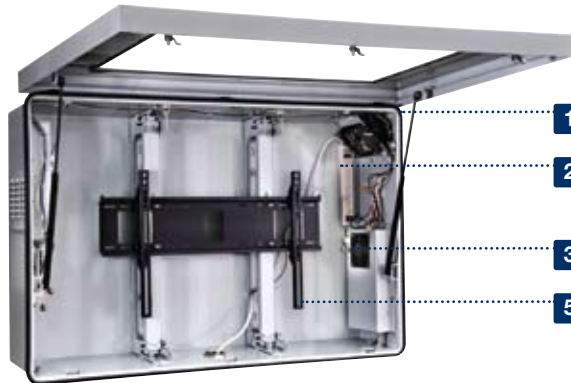

Ambient temperature range that the unit will work:

Non-Heated: 41 to 95° F (5 to 35° C)  
Heated: 5 to 95° F (-15 to 35° C)

Note: Customizable enclosures and mounts available. Call Customer Care for further details. IR remotes controls may be blocked depending on placement of sensor on certain displays.

For expanded product information and technical data visit [www.peerless-av.com](http://www.peerless-av.com)

## TECHNICAL DRAWINGS

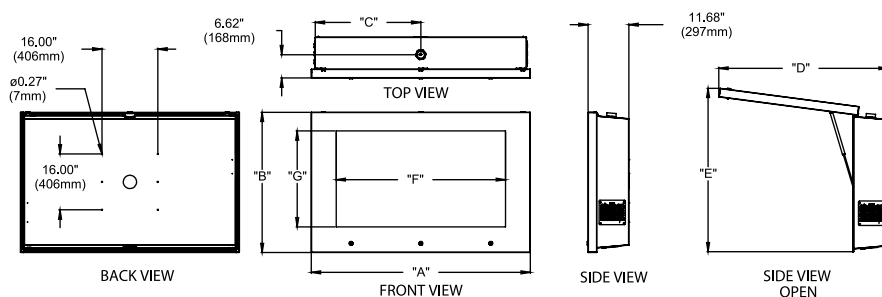

MODEL NO.	DIMENSION "A"	DIMENSION "B"	DIMENSION "C"	DIMENSION "D"	DIMENSION "E"	DIMENSION "F"	DIMENSION "G"
FPE42F-S FPE42FH-S	51.41" (1306mm)	33.80" (859mm)	25.09" (637mm)	42.18" (1071mm)	39.67" (1008mm)	36.50" (927mm)	21.00" (533mm)
FPE47F-S FPE47FH-S	55.76" (1416mm)	36.25" (921mm)	26.78" (680mm)	44.65" (1134mm)	42.20" (1072mm)	41.50" (1054mm)	23.50" (597mm)
FPE55F-S FPE55FH-S	62.74" (1594mm)	40.18" (1021mm)	30.26" (769mm)	48.51" (1232mm)	46.83" (1189mm)	48.50" (1232mm)	27.50" (699mm)

## MODELS

### Universal Models:

Includes stainless steel key lock

### Fan models:

<b>FPE42F-S</b>	Fit 40" - 42" displays	Stone Gray
<b>FPE47F-S</b>	Fit 46" - 47" displays	Stone Gray
<b>FPE55F-S</b>	Fit 52" - 55" displays	Stone Gray

### Heater models:

<b>FPE42FH-S</b>	Fit 40" - 42" displays	Stone Gray
<b>FPE47FH-S</b>	Fit 46" - 47" displays	Stone Gray
<b>FPE55FH-S</b>	Fit 52" - 55" displays	Stone Gray

## DISPLAY ADAPTER



### Mounting Pattern

Universal Models: 730 x 433mm  
(28.75"W x 17.05"H)



### VESA® Pattern

Universal Models: Up to 600 x 400mm

## SPECIFICATIONS



### Max Load

250lb (113kg)

### Product Dimensions (W x H x D)

<b>FPE42 models:</b>	51.41" x 33.80" x 11.68" (1306 x 859 x 297mm)
<b>FPE47 models:</b>	55.76" x 36.25" x 11.68" (1416 x 921 x 297mm)
<b>FPE55 models:</b>	62.74" x 40.18" x 11.68" (1594 x 1021 x 297mm)

### Available Power Load Wattage

Fan models:	1550 Watts
Heater models:	700 Watts

### Factory Set Operating Temperatures

Fans:	turn on at 70°F (21°C)
Heaters:	turn on at 40° ±7°F (4° ±7°C)
	turn off at 60° ±5°F (15° ±5°C)

### Mounting Surfaces

Wood stud, concrete and cinder block

### Ship Weight

<b>FPE42F-S:</b>	150lb (68kg)
<b>FPE47F-S:</b>	160lb (73kg)
<b>FPE55F-S:</b>	170lb (77kg)
<b>FPE42FH-S:</b>	155lb (70kg)
<b>FPE47FH-S:</b>	165lb (75kg)
<b>FPE55FH-S:</b>	175lb (79kg)

## CERTIFICATIONS



RoHS



## ACCESSORIES



**FPEWM:**  
Enclosure Wall Mount ..... pg# 200



**FPECMC-01,02,03,04:**  
Enclosure Ceiling Mount ..... pg# 200



**FPECM-01,02,03,04:**  
Enclosure I-beam Mount ..... pg# 200



**FPEPM-05,06,07,08:**  
Enclosure Pedestal Mount ..... pg# 200

To verify mount compatibility with any flat panel display or projector model use MountFinder™ at [www.peerless-av.com](http://www.peerless-av.com)



CALL: 630-375-5100  
800-865-2112



FAX: 630-820-8537  
800-359-6500



E-MAIL:  
[info@peerless-av.com](mailto:info@peerless-av.com)



ONLINE:  
[www.peerless-av.com](http://www.peerless-av.com)



# Wind Rated Tilt Wall Mount

For 32" to 65" Outdoor Flat Panel Displays

## MODELS

### Universal Models:

Includes theft resistant hardware for attaching display to socket pin  
**EWMU-S** Stone Gray  
**EWMU** Black

## DISPLAY ADAPTER

### Mounting Pattern

Universal Models: 720 x 449mm  
 (28.35"W x 17.67"H)

### VESA® Pattern

Universal Models: Up to 600 x 400mm

## SPECIFICATIONS

### Distance from Wall

3.79" (96mm)

### Tilt

+15/-5°

### Fixed Tilt

0°, 2°, 5°, 10°, 15°

### Max Load

200lb (91kg)

### Product Dimensions (W x H x D)

30.75" x 18.83" x 3.79"  
 (781 x 478 x 96mm)

### Mounting Surfaces

Wood stud, concrete and cinder block

### Ship Weight

20lb (11kg)

## CERTIFICATIONS



1. Wind rated up to 110MPH when fixed tilt mechanism is engaged
2. Designed specifically for outdoor use and constructed from weatherproof materials
3. Easy tilt settings allow for the perfect viewing angle
4. Hook-and-hang design makes installation quick and easy

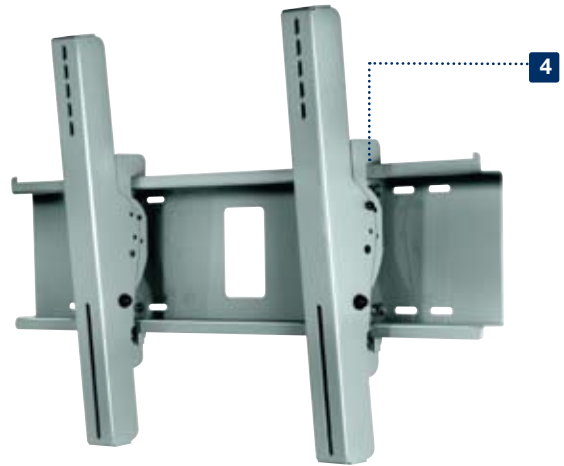

## TECHNICAL DRAWINGS

For expanded product information and technical data visit [www.peerless-av.com](http://www.peerless-av.com)

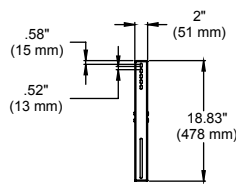

FRONT OF SCREEN ADAPTER

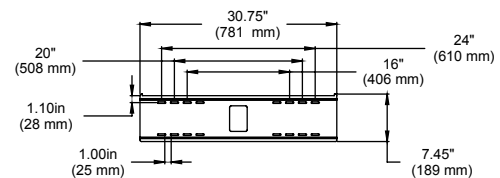

WALL PLATE

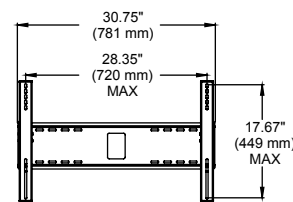

FRONT VIEW

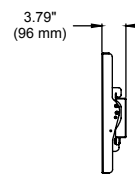

SIDE VIEW 0°

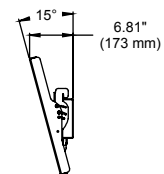

SIDE VIEW 15°

To verify mount compatibility with any flat panel display or projector model use MountFinder™ at [www.peerless-av.com](http://www.peerless-av.com)



# Wind Rated Tilt Ceiling Mount

For 32" to 65" Outdoor Flat Panel Displays

1. Wind rated to 90 MPH
2. Designed specifically for outdoor use and constructed from weatherproof materials
3. Available I-beam or concrete mounting options
4. Easy tilt settings allow for the perfect viewing angle
5. Swivel feature allows for the display to face the desired direction without adjusting the mounting plate



For expanded product information and technical data visit [www.peerless-av.com](http://www.peerless-av.com)

## TECHNICAL DRAWINGS

MODEL NO.	DIMENSION "A"	DIMENSION "B"
ECMU-1	15.02" (382mm)	19.63" (498mm)
ECMU-2	27.02" (686mm)	31.63" (803mm)
ECMU-3	39.02" (991mm)	43.63" (1108mm)
ECMU-4	51.02" (1296mm)	55.63" (1413mm)

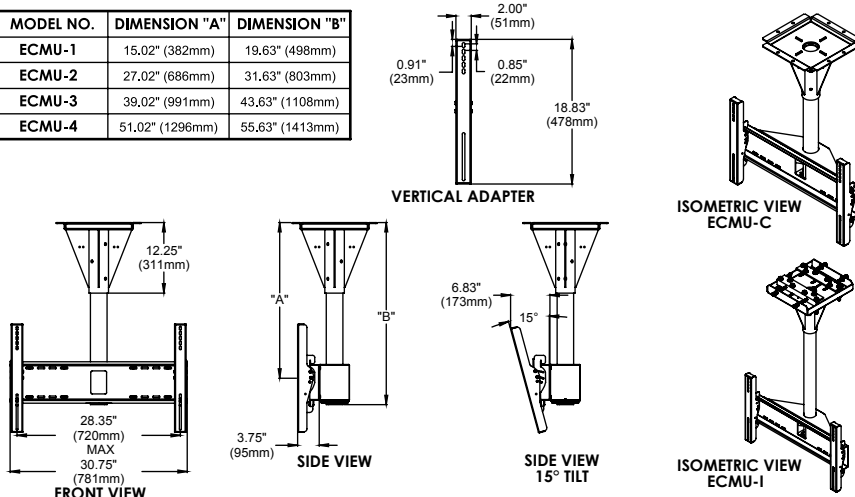

FLAT PANEL MOUNTS

## MODELS

### Universal Models:

Includes theft resistant hardware for attaching display to socket pin

### Concrete ceiling models:

<b>ECMU-01-C</b>	Black
<b>ECMU-01-C-S</b>	Stone Gray
<b>ECMU-02-C</b>	Black
<b>ECMU-02-C-S</b>	Stone Gray
<b>ECMU-03-C</b>	Black
<b>ECMU-03-C-S</b>	Stone Gray
<b>ECMU-04-C</b>	Black
<b>ECMU-04-C-S</b>	Stone Gray

### I-Beam models:

<b>ECMU-01-I</b>	Black
<b>ECMU-01-I-S</b>	Stone Gray
<b>ECMU-02-I</b>	Black
<b>ECMU-02-I-S</b>	Stone Gray
<b>ECMU-03-I</b>	Black
<b>ECMU-03-I-S</b>	Stone Gray
<b>ECMU-04-I</b>	Black
<b>ECMU-04-I-S</b>	Stone Gray

## DISPLAY ADAPTER



### Mounting Pattern

Universal Models: 720 x 449mm  
(28.35"W x 17.67"H)



### VESA® Pattern

Universal Models: Up to 600 x 400mm

## SPECIFICATIONS



### Distance from Ceiling to Center of Display

ECMU-01-C/I(-S):	15.02" (382mm)
ECMU-02-C/I(-S):	27.02" (686mm)
ECMU-03-C/I(-S):	39.02" (991mm)
ECMU-04-C/I(-S):	51.02" (1296mm)



### Tilt | Swivel

+15/-5° | 360° (22° increments)

### Fixed Tilt

-5°, 0°, 5°, 10°, 15°



### Max Load

200lb (91kg)

### Product Dimensions (H x W)

ECMU-01-C/I(-S):	24.44" x 30.75" (621 x 781mm)
ECMU-02-C/I(-S):	30.89" x 30.75" (785 x 781mm)
ECMU-03-C/I(-S):	42.89" x 30.75" (1089 x 781mm)
ECMU-04-C/I(-S):	54.89" x 30.75" (1394 x 781mm)

### Mounting Surfaces

Concrete or I-Beam

### Ship Weight

ECMU-01-C/I(-S):	70.5lb (32kg)
ECMU-02-C/I(-S):	76.5lb (35kg)
ECMU-03-C/I(-S):	81.5lb (37kg)
ECMU-04-C/I(-S):	87lb (39.5kg)

## CERTIFICATIONS



To verify mount compatibility with any flat panel display or projector model use MountFinder™ at [www.peerless-av.com](http://www.peerless-av.com)



CALL: 630-375-5100  
800-865-2112



FAX: 630-820-8537  
800-359-6500



E-MAIL:  
[info@peerless-av.com](mailto:info@peerless-av.com)



ONLINE:  
[www.peerless-av.com](http://www.peerless-av.com)





# Wind Rated Tilt Pedestal Mount

For 32" to 65" Outdoor Flat Panel Displays

## MODELS

### Universal Models:

Includes theft resistant hardware for attaching display to socket pin

<b>EPMU-05</b>	Black
<b>EPMU-05-S</b>	Stone Gray
<b>EPMU-06</b>	Black
<b>EPMU-06-S</b>	Stone Gray
<b>EPMU-07</b>	Black
<b>EPMU-07-S</b>	Stone Gray
<b>EPMU-08</b>	Black
<b>EPMU-08-S</b>	Stone Gray

## DISPLAY ADAPTER



### Mounting Pattern

Universal Models: 720 x 449mm  
(28.35"W x 17.67"H)



### VESA® Pattern

Universal Models: Up to 600 x 400mm

## SPECIFICATIONS



### Distance from Base to Center of Display

<b>EPMU-05(-S):</b>	60" (1524mm)
<b>EPMU-06(-S):</b>	72" (1800mm)
<b>EPMU-07(-S):</b>	84" (2133mm)
<b>EPMU-08(-S):</b>	96" (2438mm)



### Tilt | Swivel

+15/-5° | 360° (22° increments)

### Fixed Tilt

-5°, 0°, 5°, 10°, 15°



### Max Load

200lb (91kg)

### Product Dimensions (H x W)

<b>EPMU-05(-S):</b>	77.51" x 30.75" (1969 x 781mm)
<b>EPMU-06(-S):</b>	89.51" x 30.75" (2274 x 781mm)
<b>EPMU-07(-S):</b>	101.51" x 30.75" (2578 x 781mm)
<b>EPMU-08(-S):</b>	113.51" x 30.75" (2883 x 781mm)

### Mounting Surfaces

Concrete

### Ship Weight

<b>EPMU-05(-S):</b>	118lb (53.6kg)
<b>EPMU-06(-S):</b>	128lb (58kg)
<b>EPMU-07(-S):</b>	138lb (62.7kg)
<b>EPMU-08(-S):</b>	148lb (67kg)

## CERTIFICATIONS



1. Wind rated up to 110 MPH when fixed tilt mechanism is engaged
2. Designed specifically for outdoor use and constructed from weatherproof materials
3. Easy tilt settings allow for the perfect viewing angle
4. Swivel feature allows for the display to face the necessary direction without adjusting the pedestal
5. 8ft column meets ADA requirements



## TECHNICAL DRAWINGS

For expanded product information and technical data visit [www.peerless-av.com](http://www.peerless-av.com)

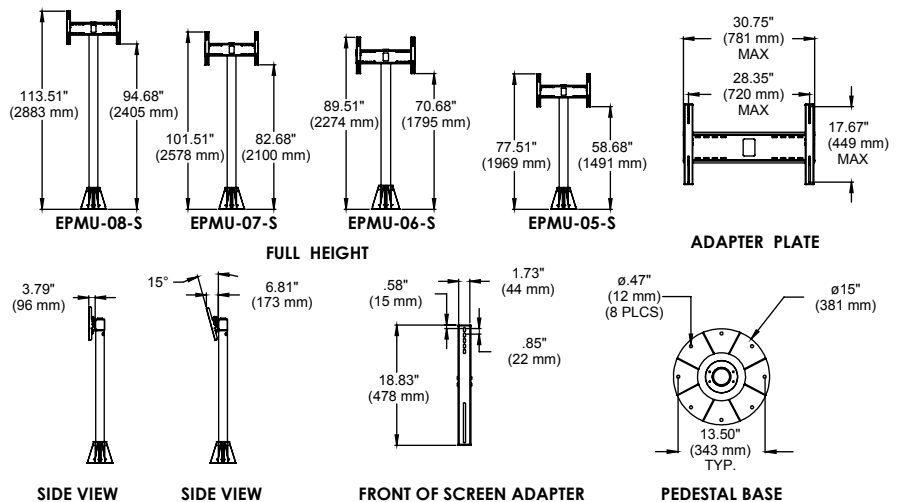

To verify mount compatibility with any flat panel display or projector model use MountFinder™ at [www.peerless-av.com](http://www.peerless-av.com)



CALL: 630-375-5100  
800-865-2112



FAX: 630-820-8537  
800-359-6500



E-MAIL: [info@peerless-av.com](mailto:info@peerless-av.com)



ONLINE: [www.peerless-av.com](http://www.peerless-av.com)



## PROJECTOR MOUNTS TABLE OF CONTENTS

Projector Mounts  
Security Projector Mounts  
Extension Columns  
Short Throw Projector Mounts

<b>PRG Models</b> PRG Projector Mount for Projectors up to 50lb (22kg) .....	pg# 135
<b>PRG-EXA/B/C Models</b> PRG Adjustable Ceiling/Wall Mount Kit for Projectors up to 50lb (22kg) .....	pg# 136
<b>PRG-ALU/KIT Models</b> PRG Adjustable Projector Mount Kit For Projectors up to 50lb (22kg) .....	pg# 137
<b>PRS Models</b> PRS Projector Mount for Projectors up to 25lb (11kg) .....	pg# 138
<b>PRS-EXA/B/C Models</b> PRS Adjustable Ceiling/Wall Mount Kit for Projectors up to 25lb (11kg) .....	pg# 139
<b>PRS-ALU/KIT Models</b> PRS Adjustable Projector Mount Kit for Projectors up to 25lb (11kg) .....	pg# 140
<b>PJF2 Models</b> PJF2 Projector Mount for Projectors up to 50lb (22kg) .....	pg# 141
<b>PRGS-UNV Model</b> PRGS Projector Mount for Projectors up to 50lb (22kg) .....	pg# 142
<b>PRGS-ALU/KIT Models</b> PRGS Adjustable Projector Mount Kit For Projectors up to 50lb (22kg) .....	pg# 143
<b>PRSS-UNV Model</b> PRSS Projector Mount for Projectors up to 25lb (11kg) .....	pg# 144
<b>PRSS-ALU/KIT Models</b> PRSS Adjustable Projector Mount Kit for Projectors up to 25lb (11kg) .....	pg# 145
<b>PAG-UNV Models</b> PAG Projector Mount for Projectors up to 25lb (11kg) .....	pg# 146
<b>PAG-UNV-HD/PAG-HDX Models</b> PAG Heavy Duty Projector Mount for Projectors up to 130lb (59kg) .....	pg# 147
<b>PPF Models</b> Flush Ceiling Projector Mount for Projectors up to 50lb (22kg) .....	pg# 148
<b>PPA/PPB/PPC Models</b> Adjustable Ceiling/Wall Projector Mount for Projectors up to 50lb (22kg) .....	pg# 149
<b>PSM-UNV/PSMU-PRS Models</b> PSM/PSMU Security Projector Mounts for Projectors up to 50lb (22kg) .....	pg# 150
<b>PE1120 Models</b> Projector Enclosure for use with Peerless-AV Projector Mounts .....	pg# 151
<b>ALU/AEC/EXT Models</b> Adjustable and Fixed Extension Columns for up to 1200lb (544kg) .....	pg# 152
<b>PSTA/PSTK Models</b> Short Throw Projector Mount for Projectors up to 25lb (11kg) .....	pg# 153

Whiteboard  
Mounts

<b>IWB600-UNIV Model</b> Universal Whiteboard Mount for attaching over existing marker boards and chalkboards .....	pg# 154
<b>IWB600-2SB/IWB600-WB Models</b> Dedicated Whiteboard Mounts for attaching over existing marker boards and chalkboards .....	pg# 155



# PROJECTOR & WHITEBOARD MOUNTS

**peerless-AV™**

 **CALL:** 630-375-5100  
800-865-2112

 **FAX:** 630-820-8537  
800-359-6500

 **E-MAIL:**  
info@peerless-av.com

 **ONLINE:**  
www.peerless-av.com



The patented Spider® Universal Adapter Plate clamp-style technology simplifies installation and enhances compatibility.

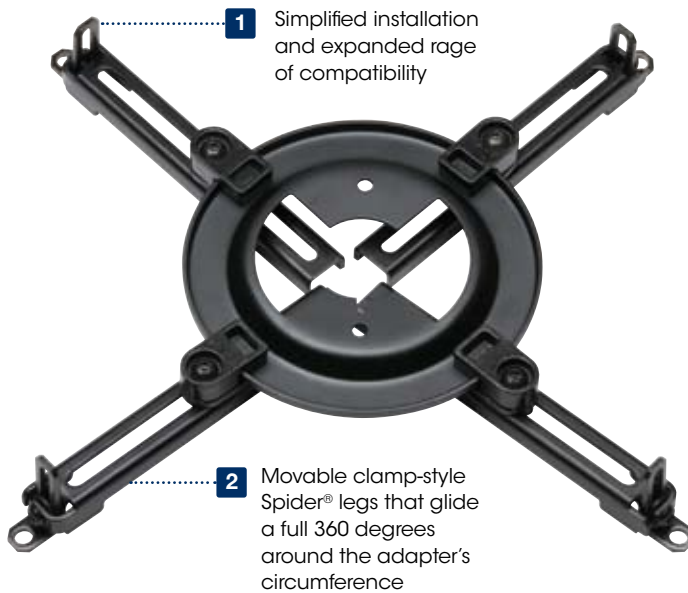

### SIMPLIFIED INSTALLATION AND LEG ADJUSTMENT

No more time-consuming leg removal and adjustment to fit the projector. Simply loosen the clamp to enable the legs to smoothly glide along the 360° path to the desired location, then tighten the clamp to secure the leg in place.

### EXPANDED RANGE OF COMPATIBILITY

This design boasts an increased reach of the adapter legs by more than an inch to accommodate projectors with larger mounting hole patterns. No more compatibility limitations with a larger adapter plate circumference and 100% guaranteed compatibility with Peerless-AV™ popular projector mount models.

















### COLOR CHOICES

Choose from a selection of colors to match the installation. Available in black, silver and white.

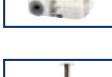

SPIDER® UNIVERSAL PROJECTOR ADAPTER PLATE TECHNOLOGY

## PEERLESS-AV™ PROJECTOR MOUNT SOLUTIONS:

- 
**PRG-UNV Models**  
 PRG Projector Mount  
 For Projectors  
 up to 50lb (22kg) ..... pg# 135
- 
**PRG-EXA/EXB/EXC Models**  
 PRG Adjustable  
 Ceiling/Wall Mount Kit  
 For Projectors  
 up to 50lb (22kg) ..... pg# 136
- 
**PRG-ALU/KIT Models**  
 PRG Adjustable  
 Projector Mount Kit  
 For Projectors  
 up to 50lb (22kg) ..... pg# 137
- 
**PRS-UNV Models**  
 PRS Projector Mount  
 For Projectors  
 up to 25lb (11kg) ..... pg# 138
- 
**PRS-EXA/EXB/EXC Models**  
 PRS Adjustable  
 Ceiling/Wall Mount Kit  
 For Projectors  
 up to 25lb (11kg) ..... pg# 139
- 
**PRS-ALU/KIT Models**  
 PRS Adjustable  
 Projector Mount Kit  
 For Projectors  
 up to 25lb (11kg) ..... pg# 140
- 
**PJF2-UNV Models**  
 PJF2 Projector Mount  
 For Projectors  
 up to 50lb (22kg) ..... pg# 141
- 
**PRGS-UNV Models**  
 PRGS Projector Mount  
 For Projectors  
 up to 50lb (22kg) ..... pg# 142
- 
**PRGS-ALU/KIT Models**  
 PRGS Adjustable  
 Projector Mount Kit  
 For Projectors  
 up to 50lb (22kg) ..... pg# 143
- 
**PRSS-UNV Models**  
 PRSS Projector Mount  
 For Projectors  
 up to 25lb (11kg) ..... pg# 144
- 
**PRSS-ALU/KIT Models**  
 PRSS Adjustable  
 Projector Mount Kit  
 For Projectors  
 up to 25lb (11kg) ..... pg# 145
- 
**PAG-UNV Models**  
 PAG Projector Mount  
 For Projectors up to 25lb  
 (11kg) & 50lb (22kg) .. pg# 146
- 
**PAG-UNV-HD Models**  
 PAG Heavy Duty  
 Projector Mount  
 For Projectors  
 up to 100lb (45kg) ..... pg# 147
- 
**PPF Models**  
 Flush Ceiling  
 Projector Mount  
 For Projectors  
 up to 50lb (22kg) ..... pg# 148
- 
**PPA/B/C Models**  
 Adjustable Ceiling/Wall  
 Projector Mount  
 For Projectors  
 up to 50lb (22kg) ..... pg# 149
- 
**PSTA/PSTK Models**  
 Short Throw  
 Projector Mount  
 For Projectors  
 up to 25lb (11kg) ..... pg# 153

# PROJECTOR MOUNT AND ACCESSORIES SELECTION GUIDE

Choosing the perfect combination of projector mount and accessories for your installation is now simpler than ever. Refer to the chart below for a quick reference selection guide for the ideal mount and needed accessories.

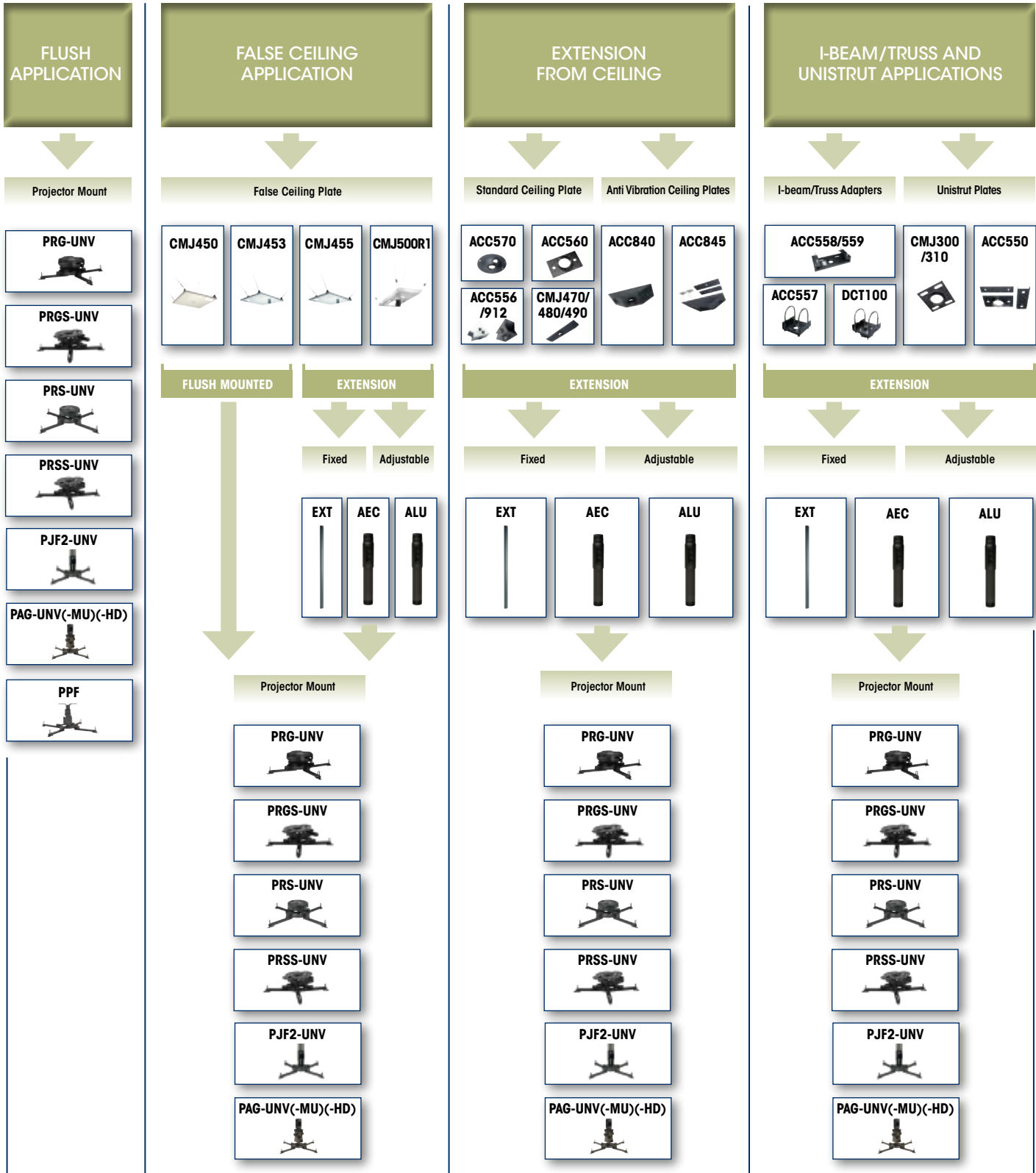

# PRG Projector Mount

For Projectors up to 50lb (22kg)

1. Spider® Universal Adapter Plate extends up to 17.63" (448mm) to fit most projector models
2. Precision gearing provides ImageLock™ alignment to accurately hold image position, virtually eliminating any sag or drift
3. Two adjustment knobs control tilt and roll image alignment. Engage using a Phillips screwdriver or extend knobs to adjust by hand
4. Cable management allows cables to be routed through projector mount and out of sight
5. Quick-release mechanism to easily service projector
6. Pre-installed security screws provide optional tilt and roll lock to prevent tampering with adjustment knobs



Patented

For expanded product information and technical data visit [www.peerless-av.com](http://www.peerless-av.com)

## TECHNICAL DRAWINGS

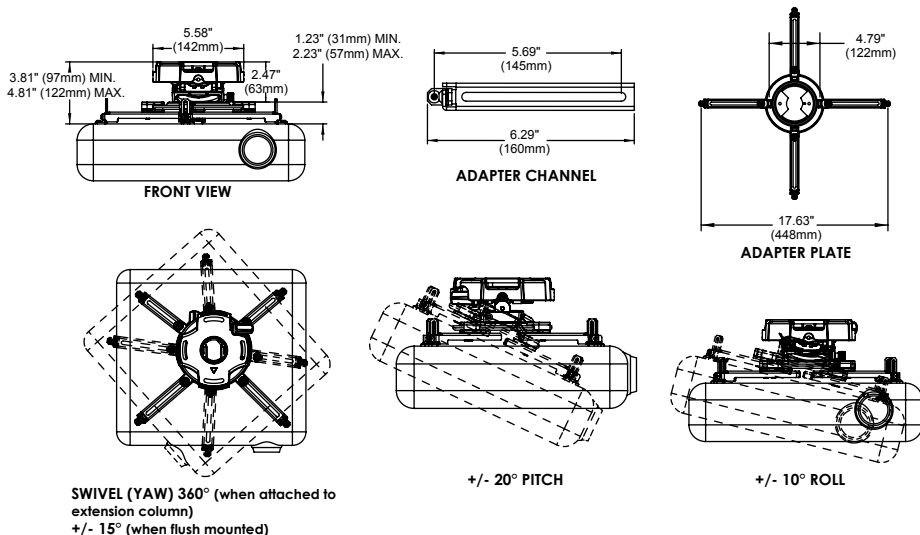

To verify mount compatibility with any flat panel display or projector model use MountFinder™ at [www.peerless-av.com](http://www.peerless-av.com)



CALL: 630-375-5100  
800-865-2112



FAX: 630-820-8537  
800-359-6500



E-MAIL:  
[info@peerless-av.com](mailto:info@peerless-av.com)



ONLINE:  
[www.peerless-av.com](http://www.peerless-av.com)



PROJECTOR &  
WHITEBOARD  
MOUNTS

## MODELS

### Universal Models:

Includes theft resistant hardware for attaching projector to mount

<b>PRG-UNV</b>	Black
<b>PRG-UNV-S</b>	Silver
<b>PRG-UNV-W</b>	White

### Kitted Dedicated Models:

Includes dedicated projector adapter plate

<b>PRG-MODELS</b>	Black
-------------------	-------

### Dedicated Models:

Projector adapter purchased separately\*

<b>PRG-1(-S)(-W)</b>	Black, silver or white
----------------------	------------------------

\*Dedicated adapter plates come in flat black and include security fasteners

## PROJECTOR ADAPTER



### Mounting Pattern

Universal Models: Up to 17.63" (448mm)

Kitted Dedicated Models: Includes dedicated projector adapter plate. Use MountFinder™ to verify model.

Dedicated Models: Requires projector specific adapter plate to be purchased separately.

## SPECIFICATIONS



### Tilt | Swivel | Roll

±20° | 360° (±15° when flush mounted) | ±10°



### Max Load

50lb (22kg)

### Product Dimensions (W x H x D)

Universal Models: 8.50"-17.63" x 3.81"-4.81"  
x 8.50"-17.63"  
(216-448 x 97-122 x 216-448mm)

Dedicated Models: 5.58" x 2.47" x 5.58"  
(142 x 63 x 142mm)

### Mounting Surfaces

Wood joist, concrete  
and other structures  
(Other structures require accessory)

### Ship Weight

Universal Models: 3.78lb (1.72kg)  
Dedicated Models: 1.8lb (.82kg)

## CERTIFICATIONS



## ACCESSORIES



**ACC, CMJ Models:**  
Ceiling Plates ..... pg# 190, 192



**AEC, ALU and EXT Models:**  
Extension Columns ..... pg# 152



**PWA-14(S)(W):**  
Projector Wall Arm ..... pg# 195



**EX Models:**  
Ceiling/Wall Extension Kits ... pg# 194



# PRG Adjustable Ceiling/Wall Mount Kit

For Projectors up to 50lb (22kg)

## MODELS

### Universal Models:

Includes theft resistant hardware for attaching projector to mount

With 8.70"-12.80" (221-325mm) ceiling extension  
and 9.72"-13.86" (247-352mm) wall extension:

**PRG-EXA** Black  
**PRG-EXA-S** Silver  
**PRG-EXA-W** White

With 12.68"-20.67" (322-525mm) ceiling extension  
and 13.74"-21.73" (349-552mm) wall extension:

**PRG-EXB** Black  
**PRG-EXB-S** Silver  
**PRG-EXB-W** White

With 19.13"-32.91" (486-836mm) ceiling extension:

**PRG-EXC** Black  
**PRG-EXC-S** Silver  
**PRG-EXC-W** White

## PROJECTOR ADAPTER



### Mounting Pattern

Universal Models: Up to 17.63" (448mm)

## SPECIFICATIONS



### Distance from Ceiling

PRG-EXA(-S)(-W): 8.70"-12.80" (221-325mm)  
PRG-EXB(-S)(-W): 12.68"-20.67" (322-525mm)  
PRG-EXC(-S)(-W): 19.13"-32.91" (486-836mm)



### Distance from Wall

PRG-EXA(-S)(-W): 9.72"-13.86" (247-352mm)  
PRG-EXB(-S)(-W): 13.74"-21.73" (349-552mm)



### Tilt | Swivel | Roll

±20° | 360° | ±10°



### Max Load

50lb (22kg)

### Product Dimensions (W x D)

8.50"-17.63" x 8.50"-17.63"  
(216-448 x 216-448mm)

### Mounting Surfaces

Wood joist, wood stud,  
concrete and other structures  
(Other structures require accessory)

### Ship Weight

PRG-EXA(-S)(-W): 7.75lb (3.52kg)  
PRG-EXB(-S)(-W): 8.11lb (3.68kg)  
PRG-EXC(-S)(-W): 9.28lb (4.21kg)

## CERTIFICATIONS



## ACCESSORIES



**ACC575:**  
Threaded Connector  
Accessory.....pg# 193



**ACC-EXC:**  
Extension Column  
for EXC Extension Kit .....pg# 194

1. Spider® Universal Adapter Plate extends up to 17.63" (448mm) to fit most projector models
2. Mounts to ceiling or wall\* with included wall mount interface  
*\* PRG-EXA and PRG-EXB models only. PRG-EXC is not wall mountable due to its extensive reach.*
3. Two adjustment knobs control tilt and roll image alignment. Engage using a Phillips screwdriver or extend knobs to align by hand
4. Continuous channel design for uninterrupted drop length or wall extension adjustments
5. Safety catch designed into extension to ensure user and equipment safety
6. Internal cable management channels for clean, clutter-free appearance



Patented

## TECHNICAL DRAWINGS

For expanded product information and technical data visit [www.peerless-av.com](http://www.peerless-av.com)

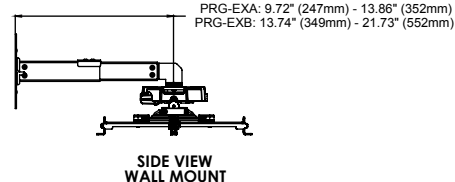
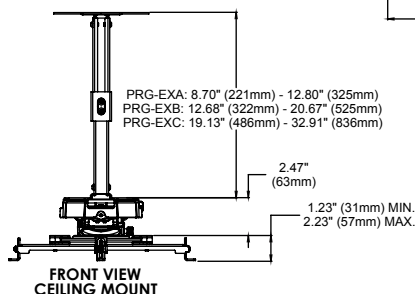
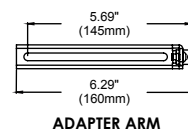
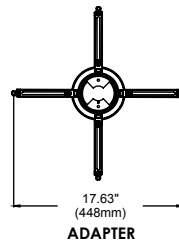
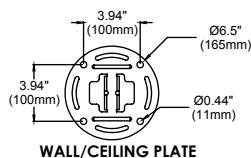

PRG-EXA: 8.70" (221mm) - 12.80" (325mm)  
PRG-EXB: 12.68" (322mm) - 20.67" (525mm)  
PRG-EXC: 19.13" (486mm) - 32.91" (836mm)

PRG-EXA: 9.72" (247mm) - 13.86" (352mm)  
PRG-EXB: 13.74" (349mm) - 21.73" (552mm)

To verify mount compatibility with any flat panel display or projector model use MountFinder™ at [www.peerless-av.com](http://www.peerless-av.com)



CALL: 630-375-5100  
800-865-2112



FAX: 630-820-8537  
800-359-6500



E-MAIL:  
[info@peerless-av.com](mailto:info@peerless-av.com)



ONLINE:  
[www.peerless-av.com](http://www.peerless-av.com)



# PRG Adjustable Projector Mount Kit

For Projectors up to 50lb (22kg)

1. Spider® Universal Adapter Plate extends up to 17.63" (448mm) to fit most projector models
2. 1-1/2" x 11.5 NPT (38mm) adjustment column comes in three adjustment height ranges in 1" (25mm) increments:  
 6"-9" (152-229mm)  
 12"-18" (305-457mm)  
 18"-24" (457-610mm)
3. Keep cables out of sight by routing them through the projector mount and extension column
4. Two adjustment knobs to control tilt and roll image alignment and accurately hold image position, virtually eliminating any sag or drift
5. Quick release mechanism to easily service projector
6. Pre-installed security screws provide optional tilt and roll lock to prevent tampering and adjustments

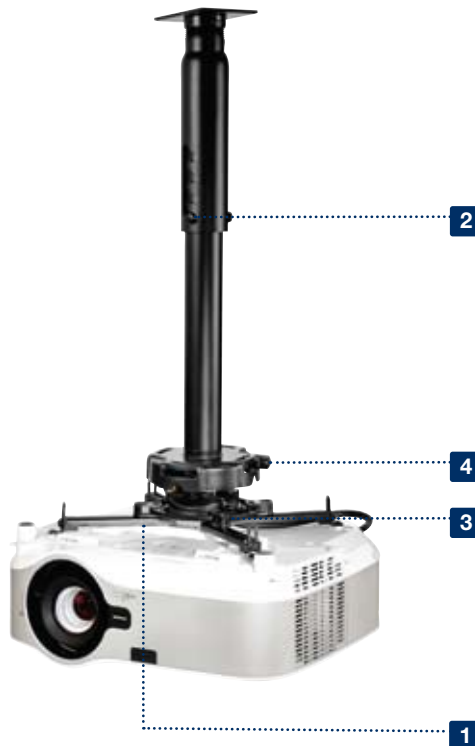

For expanded product information and technical data visit [www.peerless-av.com](http://www.peerless-av.com)

## TECHNICAL DRAWINGS

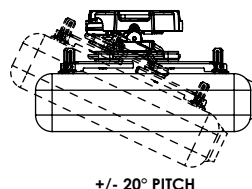
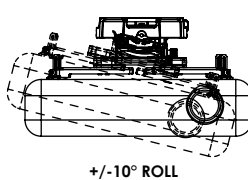
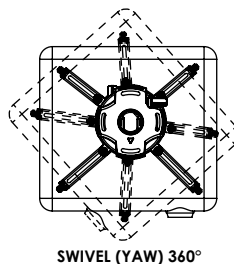
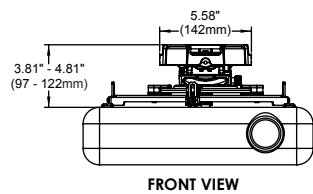
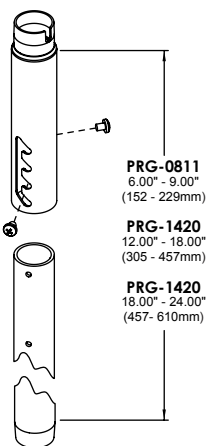

PROJECTOR &  
WHITEBOARD  
MOUNTS

## MODELS

### Universal Models:

Includes theft resistant hardware for attaching projector to mount

Kitted with Aluminum Adjustable Extension Column:

**PRG-ALU0811** Black  
**PRG-ALU1420** Black  
**PRG-ALU2026** Black

Kitted with Steel Adjustable Extension Column:

**PRG-KIT0811** Black  
**PRG-KIT1420** Black  
**PRG-KIT2026** Black

## PROJECTOR ADAPTER



### Mounting Pattern

Universal Models: Up to 17.63" (448mm)

## SPECIFICATIONS



### Distance from Ceiling

**PRG-ALU/KIT0811:** 6"-9" (152-229mm)  
**PRG-ALU/KIT1420:** 12"-18" (305-457mm)  
**PRG-ALU/KIT2026:** 18"-24" (457-610mm)



### Tilt | Swivel | Roll

±20° | 360° | ±10°



### Max Load

50lb (22kg)



### Product Dimensions (W x D)

8.50"-17.63" x 8.50"-17.63"  
(216-448 x 216-448mm)

### Mounting Surfaces

Wood joist, concrete  
and other structures  
(Other structures require accessory)

### Ship Weight

**PRG-ALU0811:** 7lb (3kg)  
**PRG-ALU1420:** 7.9lb (4kg)  
**PRG-ALU2026:** 8.6lb (4kg)  
**PRG-KIT0811:** 8.6lb (4kg)  
**PRG-KIT1420:** 9.3lb (4kg)  
**PRG-KIT2026:** 10.7lb (5kg)

## CERTIFICATIONS



## ACCESSORIES



**ACC, CMJ Models:**  
Ceiling Plates .....pg# 190, 192

To verify mount compatibility with any flat panel display or projector model use MountFinder™ at [www.peerless-av.com](http://www.peerless-av.com)



**CALL:** 630-375-5100  
800-865-2112



**FAX:** 630-820-8537  
800-359-6500



**E-MAIL:**  
[info@peerless-av.com](mailto:info@peerless-av.com)



**ONLINE:**  
[www.peerless-av.com](http://www.peerless-av.com)



# PRS Projector Mount

For Projectors up to 25lb (11kg)

## MODELS

### Universal Models:

Includes theft resistant hardware for attaching projector to mount

<b>PRS-UNV</b>	Black
<b>PRS-UNV-S</b>	Silver
<b>PRS-UNV-W</b>	White

### Kitted Dedicated Models:

Includes dedicated projector adapter plate

<b>PRS-MODELS</b>	Black
-------------------	-------

### Dedicated Models:

Projector adapter purchased separately\*

<b>PRS-1(-S)(-W)</b>	Black, silver or white
----------------------	------------------------

\*Dedicated adapter plates come in flat black and include security fasteners

## PROJECTOR ADAPTER



### Mounting Pattern

**Universal Models:** Up to 17.63" (448mm)

**Kitted Dedicated Models:** Includes dedicated projector adapter plate. Use MountFinder™ to verify model.

**Dedicated Models:** Requires projector specific adapter plate to be purchased separately.

## SPECIFICATIONS



### Tilt | Swivel | Roll

+5°/-20° | 360° (±15° when flush mounted) | ±10°



### Max Load

25lb (11kg)

### Product Dimensions (W x H x D)

**Universal Models:** 8.50"-17.63" x 3.45"-4.45"  
x 8.50"-17.63"  
(216-448 x 88-113 x 216-448mm)

**Dedicated Models:** 4.60" x 2.20" x 4.60"  
(116 x 55 x 116mm)

### Mounting Surfaces

Wood joist, concrete  
and other structures  
(Other structures require accessory)

### Ship Weight

**Universal Models:** 3.5lb (1.6kg)  
**Dedicated Models:** 1.4lb (.6kg)

## CERTIFICATIONS



## ACCESSORIES



**ACC, CMJ Models:**  
Ceiling Plates .....pg# 190, 192



**AEC, ALU and EXT Models:**  
Extension Columns ..... pg# 152



**PWA-14(S)(W):**  
Projector Wall Arm ..... pg# 195



**EX Models:**  
Ceiling/Wall Extension Kits ..... pg# 194



**ACC810:**  
Threaded Rod Adapter ..... pg# 194

1. Spider® Universal Adapter Plate extends up to 17.63" (448mm) to fit most projector models
2. Three axes of adjustment enable precise image alignment
3. Dedicated adapter plates available for specific projector models
4. Available clamp-style adapter plates have adjustable height and width to fit most projectors
5. Cable management allows cables to be routed through projector mount and out of sight
6. Security fasteners at every connection point
7. Quick-release mechanism to easily service projector
8. Low-profile design allows projector to be flush with the ceiling



Patented

## TECHNICAL DRAWINGS

For expanded product information and technical data visit [www.peerless-av.com](http://www.peerless-av.com)

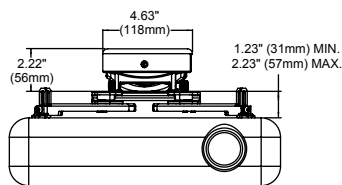

FRONT VIEW

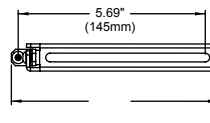

ADAPTER CHANNEL

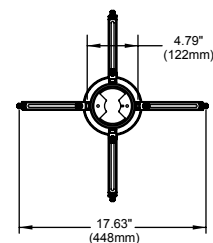

ADAPTER PLATE

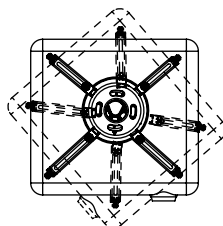

**SWIVEL (YAW) 360°** (when attached to extension column)  
+/- 15° (when flush mounted)

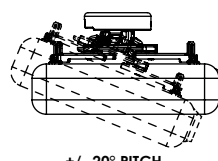

+/- 20° PITCH

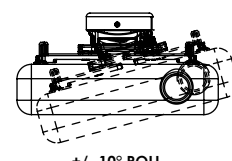

+/- 10° ROLL

To verify mount compatibility with any flat panel display or projector model use MountFinder™ at [www.peerless-av.com](http://www.peerless-av.com)



CALL: 630-375-5100  
800-865-2112



FAX: 630-820-8537  
800-359-6500



E-MAIL:  
[info@peerless-av.com](mailto:info@peerless-av.com)



ONLINE:  
[www.peerless-av.com](http://www.peerless-av.com)

# PRS Adjustable Ceiling/Wall Mount Kit

For Projectors up to 25lb (11kg)



PROJECTOR & WHITEBOARD MOUNTS

1. Spider® Universal Adapter Plate extends up to 17.63" (448mm) to fit most projector models
2. Mounts to ceiling or wall\* with included wall mount interface  
 \* PRS-EXA and PRS-EXB models only. PRS-EXC is not wall mountable due to its extensive reach.
3. Continuous channel design for uninterrupted drop length or wall extension adjustments
4. Safety catch designed into extension to ensure user and equipment safety
5. Internal cable management channels for clean, clutter-free appearance



Patented

For expanded product information and technical data visit [www.peerless-av.com](http://www.peerless-av.com)

## TECHNICAL DRAWINGS

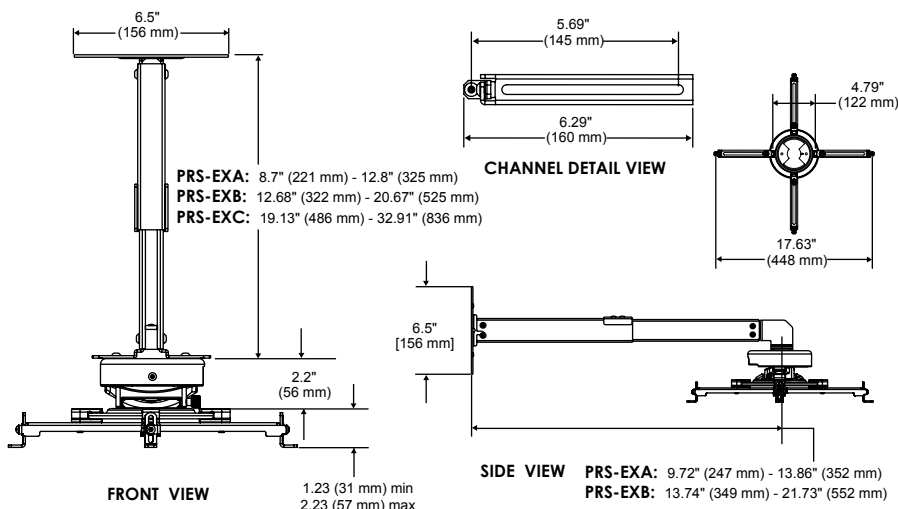

## MODELS

### Universal Models:

Includes theft resistant hardware for attaching projector to mount

With 8.70"-12.80" (221-325mm) ceiling extension and 9.72"-13.86" (247-352mm) wall extension:

**PRS-EXA** Black  
**PRS-EXA-S** Silver  
**PRS-EXA-W** White

With 12.68"-20.67" (322-525mm) ceiling extension and 13.74"-21.73" (349-552mm) wall extension:

**PRS-EXB** Black  
**PRS-EXB-S** Silver  
**PRS-EXB-W** White

With 19.13"-32.91" (486-836mm) ceiling extension:

**PRS-EXC** Black  
**PRS-EXC-S** Silver  
**PRS-EXC-W** White

## PROJECTOR ADAPTER



### Mounting Pattern

Universal Models: Up to 17.63" (448mm)

## SPECIFICATIONS



### Distance from Ceiling

PRS-EXA(-S)(-W): 8.70"-12.80" (221-325mm)  
 PRS-EXB(-S)(-W): 12.68"-20.67" (322-525mm)  
 PRS-EXC(-S)(-W): 19.13"-32.91" (486-836mm)



### Distance from Wall

PRS-EXA(-S)(-W): 9.72"-13.86" (247-352mm)  
 PRS-EXB(-S)(-W): 13.74"-21.73" (349-552mm)



### Tilt | Swivel | Roll

+5°/-20° | 360° | ±10°



### Max Load

25lb (11kg)

### Product Dimensions (W x D)

8.50"-17.63" x 8.50"-17.63"  
 (216-448 x 216-448mm)

### Mounting Surfaces

Wood joist, wood stud, concrete and other structures  
 (Other structures require accessory)

### Ship Weight

PRS-EXA(-S)(-W): 7.46lb (3.38kg)  
 PRS-EXB(-S)(-W): 7.82lb (3.55kg)  
 PRS-EXC(-S)(-W): 8.99lb (4.08kg)

## CERTIFICATIONS



## ACCESSORIES



**ACC575:**  
 Threaded Connector  
 Accessory.....pg# 193



**ACC-EXC:**  
 Extension Column  
 for EXC Extension Kit .....pg# 194

To verify mount compatibility with any flat panel display or projector model use MountFinder™ at [www.peerless-av.com](http://www.peerless-av.com)



**CALL:** 630-375-5100  
 800-865-2112



**FAX:** 630-820-8537  
 800-359-6500



**E-MAIL:**  
[info@peerless-av.com](mailto:info@peerless-av.com)



**ONLINE:**  
[www.peerless-av.com](http://www.peerless-av.com)



# PRS Adjustable Projector Mount Kit

For Projectors up to 25lb (11kg)

## MODELS

### Universal Models:

Includes theft resistant hardware for attaching projector to mount

Kitted with Aluminum Adjustable Extension Column:

- PRS-ALU0811** Black
- PRS-ALU1420** Black
- PRS-ALU2026** Black

Kitted with Steel Adjustable Extension Column:

- PRS-KIT0811** Black
- PRS-KIT1420** Black
- PRS-KIT2026** Black

## PROJECTOR ADAPTER

### Mounting Pattern

Universal Models: Up to 17.63" (448mm)

## SPECIFICATIONS

### Distance from Ceiling

- PRS-ALU/KIT0811: 6"-9" (152-229mm)
- PRS-ALU/KIT1420: 12"-18" (305-457mm)
- PRS-ALU/KIT2026: 18"-24" (457-610mm)

### Tilt | Swivel | Roll

+5°/-20° | 360° | ±10°

### Max Load

25lb (11kg)

### Product Dimensions (W x D)

8.50"-17.63" x 8.50"-17.63"  
(216-448 x 216-448mm)

### Mounting Surfaces

Wood joist, concrete  
and other structures  
(Other structures require accessory)

### Ship Weight

- PRS-ALU0811: 7.00lb (3kg)
- PRS-ALU1420: 7.90lb (4kg)
- PRS-ALU2026: 8.60lb (4kg)
- PRS-KIT0811: 7.44lb (3.77kg)
- PRS-KIT1420: 9.24lb (4.19kg)
- PRS-KIT2026: 10.78lb (4.88kg)

## CERTIFICATIONS



## ACCESSORIES

**ACC, CMJ Models:**  
Ceiling Plates .....pg# 190, 192

1. Spider® Universal Adapter Plate extends up to 17.63" (448mm) to fit most projector models
2. Includes ceiling plate for wood or concrete ceiling
3. Comes in three adjustable height ranges in 1" (25mm) increments:  
6"-9" (152-229mm)  
12"-18" (305-457mm)  
18"-24" (457-610mm)
4. Uses 1-1/2" x 11.5 NPT adjustable extension column
5. Cable management allows cables to be routed through projector mount and out of sight

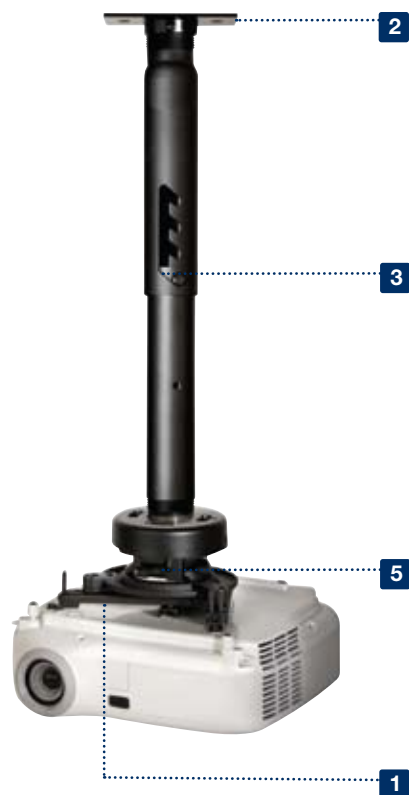

Patented

## TECHNICAL DRAWINGS

For expanded product information and technical data visit [www.peerless-av.com](http://www.peerless-av.com)

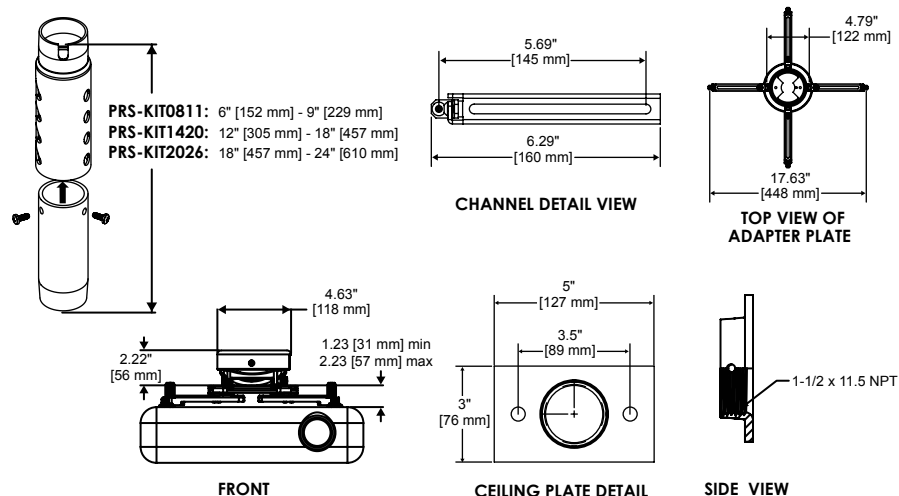

To verify mount compatibility with any flat panel display or projector model use MountFinder™ at [www.peerless-av.com](http://www.peerless-av.com)

# PJF2 Projector Mount

For Projectors up to 50lb (22kg)

1. Spider® Universal Adapter Plate extends up to 17.63" (448mm) to fit most projector models
2. Single point of adjustment for quick image alignment
3. Two thumb screws allow fast projector removal for lamp and filter maintenance
4. Cords routed internally through extension column
5. Dedicated adapter plates available for specific projector models
6. Available clamp-style adapter plates have adjustable height and width to fit most projectors

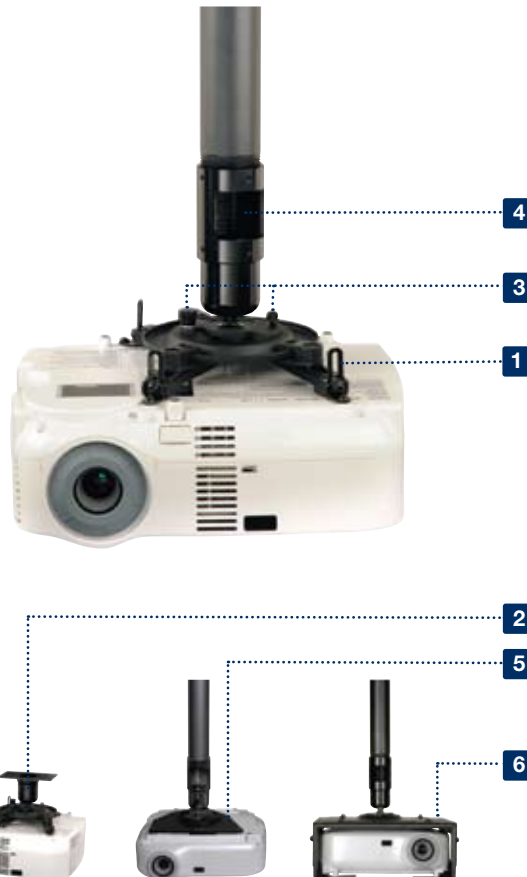

Patented

For expanded product information and technical data visit [www.peerless-av.com](http://www.peerless-av.com)

## TECHNICAL DRAWINGS

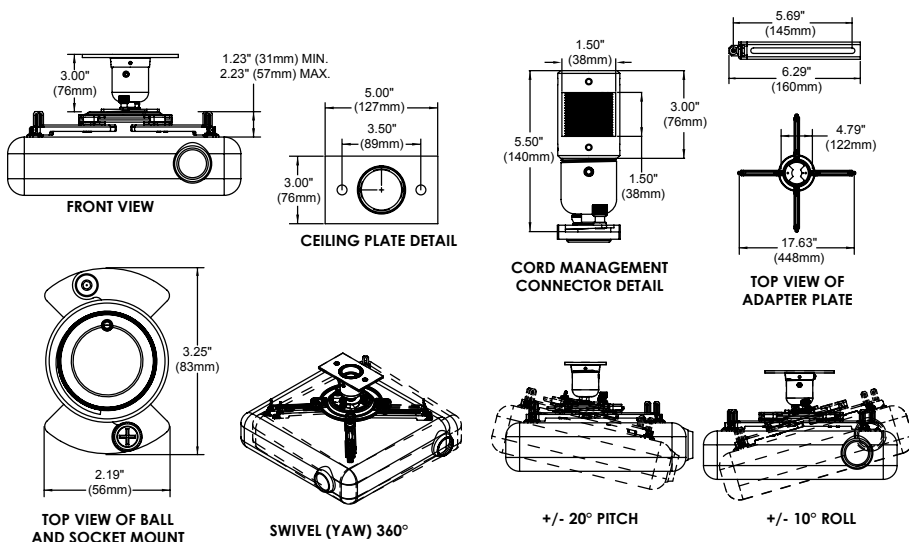

PROJECTOR & WHITEBOARD MOUNTS

## MODELS

### Universal Models:

Includes theft resistant hardware for attaching projector to mount

<b>PJF2-UNV</b>	Black
<b>PJF2-UNV-S</b>	Silver

### Kitted Dedicated Models:

Includes dedicated projector adapter plate

<b>PJF2-MODELS</b>	Black
--------------------	-------

### Dedicated Models:

Projector adapter purchased separately\*

<b>PJF2-1</b>	Black
---------------	-------

\* Dedicated adapter plates come in flat black and include security fasteners

## PROJECTOR ADAPTER



### Mounting Pattern

**Universal Models:** Up to 17.63" (448mm)

**Kitted Dedicated Models:** Includes dedicated projector adapter plate. Use MountFinder™ to verify model.

**Dedicated Models:** Requires projector specific adapter plate to be purchased separately.

## SPECIFICATIONS



### Tilt | Swivel | Roll

±15° | 360° | ±15°



### Max Load

50lb (22kg)

### Product Dimensions (W x H x D)

**Universal Models:** 8.50"-17.63" x 4.23"-5.23" x 8.50"-17.63"  
(216-448 x 107-133 x 216-448mm)

**Dedicated Models:** 3.25" x 3.13" x 3.25"  
(83 x 79 x 83mm)

### Mounting Surfaces

Wood joist, concrete and other structures  
(Other structures require accessory)

### Ship Weight

**Universal Models:** 3.58lb (1.6kg)

**Dedicated Models:** 1.31lb (.58kg)

## CERTIFICATIONS



## ACCESSORIES



**ACC, CMJ Models:**  
Ceiling Plates ..... pg# 190, 192



**AEC, ALU and EXT Models:**  
Extension Columns ..... pg# 152



**PWA-14(S)(W):**  
Projector Wall Arm ..... pg# 195

To verify mount compatibility with any flat panel display or projector model use MountFinder™ at [www.peerless-av.com](http://www.peerless-av.com)



**CALL:** 630-375-5100  
800-865-2112



**FAX:** 630-820-8537  
800-359-6500



**E-MAIL:**  
[info@peerless-av.com](mailto:info@peerless-av.com)



**ONLINE:**  
[www.peerless-av.com](http://www.peerless-av.com)





# PRGS Projector Mount

For Projectors up to 50lb (22kg)

## MODELS

### Universal Models:

Includes theft resistant hardware for attaching projector to mount  
**PRGS-UNV** Black

## PROJECTOR ADAPTER

### Mounting Pattern

Universal Models: Up to 17.63" (448mm)

## SPECIFICATIONS

### Tilt | Swivel | Roll

+15°/-20° | 360° | ±5°

### Max Load

50lb (22kg)

### Product Dimensions (W x H x D)

8.50"-17.63" x 3.60"-4.60"  
 x 8.50"-17.63"  
 (216-448 x 92-118 x 216-448mm)

### Mounting Surfaces

Wood joist, concrete  
 and other structures  
 (Other structures require accessory)

### Ship Weight

4.9lb (2kg)

## CERTIFICATIONS



## ACCESSORIES



**ACC, CMJ Models:**  
 Ceiling Plates ..... pg# 190, 192



**AEC, ALU and EXT Models:**  
 Extension Columns ..... pg# 152



**PWA-14(S)(W):**  
 Projector Wall Arm ..... pg# 195



**EX Models:**  
 Ceiling/Wall Extension Kits ... pg# 194

- Spider® Universal Adapter Plate extends up to 17.63" (448mm) to fit most projector models
- Low profile design allows projector to be flush with the ceiling
- Cable management allows cables to be routed through projector mount and out of sight
- Two adjustment knobs to control tilt and roll image alignment and accurately hold image position, virtually eliminating any sag or drift
- Quick release mechanism to easily service projector
- Pre-installed security screws provide optional tilt and roll lock to prevent tampering and adjustments



Patent Pending

## TECHNICAL DRAWINGS

For expanded product information and technical data visit [www.peerless-av.com](http://www.peerless-av.com)

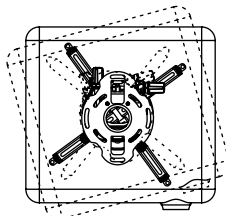
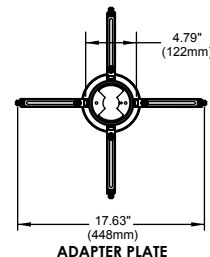
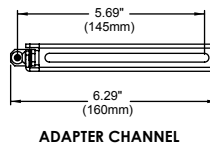
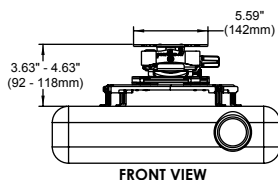

**SWIVEL (YAW) 360°** (when attached to extension column)  
 +/- 15° (when flush mounted)

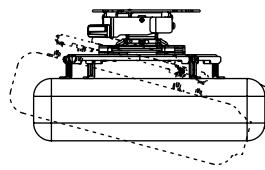

**+15/- 20° PITCH**

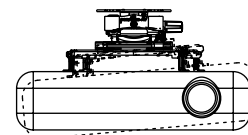

**+/- 5° ROLL**

To verify mount compatibility with any flat panel display or projector model use MountFinder™ at [www.peerless-av.com](http://www.peerless-av.com)



**CALL:** 630-375-5100  
 800-865-2112



**FAX:** 630-820-8537  
 800-359-6500



**E-MAIL:**  
[info@peerless-av.com](mailto:info@peerless-av.com)



**ONLINE:**  
[www.peerless-av.com](http://www.peerless-av.com)



# PRGS Adjustable Projector Mount Kit

For Projectors up to 50lb (22kg)

1. Spider® Universal Adapter Plate extends up to 17.63" (448mm) to fit most projector models
2. 1-1/2" x 11.5 NPT (38mm) adjustment column comes in three adjustment height ranges in 1" (25mm) increments:  
 6"-9" (152-229mm)  
 12"-18" (305-457mm)  
 18"-24" (457-610mm)
3. Keep cables out of sight by routing them through the projector mount and extension column
4. Two adjustment knobs to control tilt and roll image alignment and accurately hold image position, virtually eliminating any sag or drift
5. Quick release mechanism to easily service projector
6. Pre-installed security screws provide optional tilt and roll lock to prevent tampering and adjustments

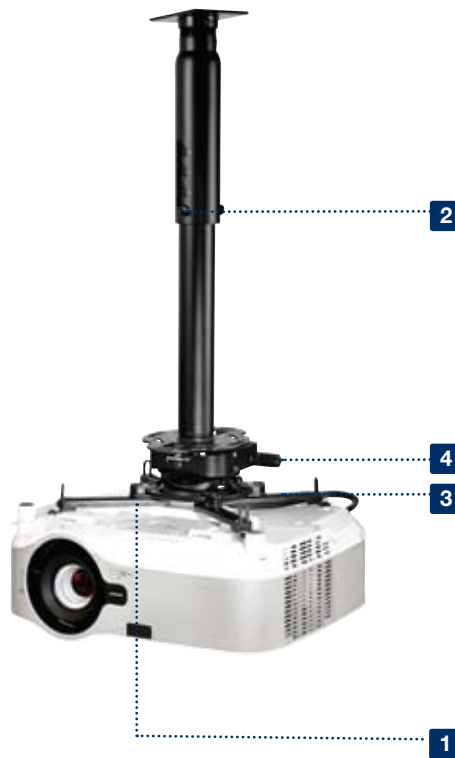

Patent Pending

For expanded product information and technical data visit [www.peerless-av.com](http://www.peerless-av.com)

## TECHNICAL DRAWINGS

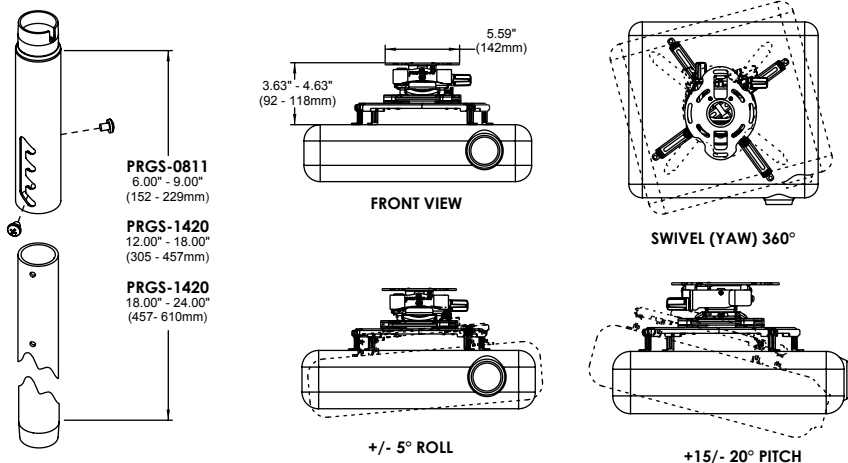

To verify mount compatibility with any flat panel display or projector model use MountFinder™ at [www.peerless-av.com](http://www.peerless-av.com)



CALL: 630-375-5100  
800-865-2112



FAX: 630-820-8537  
800-359-6500



E-MAIL: [info@peerless-av.com](mailto:info@peerless-av.com)



ONLINE: [www.peerless-av.com](http://www.peerless-av.com)



PROJECTOR &  
WHITEBOARD  
MOUNTS

## MODELS

### Universal Models:

Includes theft resistant hardware for attaching projector to mount

Kitted with Aluminum Adjustable Extension Column:

**PRGS-ALU0811** Black  
**PRGS-ALU1420** Black  
**PRGS-ALU2026** Black

Kitted with Steel Adjustable Extension Column:

**PRGS-KIT0811** Black  
**PRGS-KIT1420** Black  
**PRGS-KIT2026** Black

## PROJECTOR ADAPTER



### Mounting Pattern

Universal Models: Up to 17.63" (448mm)

## SPECIFICATIONS



### Distance from Ceiling

PRGS-ALU/KIT0811: 6"-9" (152-229mm)  
 PRGS-ALU/KIT1420: 12"-18" (305-457mm)  
 PRGS-ALU/KIT2026: 18"-24" (457-610mm)



### Tilt | Swivel | Roll

+15°/-20° | 360° | ±5°



### Max Load

50lb (22kg)



### Product Dimensions (W x D)

8.50"-17.63" x 8.50"-17.63"  
 (216-448 x 216-448mm)

### Mounting Surfaces

Wood joist, concrete  
 and other structures  
 (Other structures require accessory)

### Ship Weight

PRGS-ALU0811: 8.2lb (4kg)  
 PRGS-ALU1420: 9.1lb (4kg)  
 PRGS-ALU2026: 9.8lb (4kg)  
 PRGS-KIT0811: 8.8lb (4kg)  
 PRGS-KIT1420: 10.6lb (5kg)  
 PRGS-KIT2026: 13.9lb (6kg)

## CERTIFICATIONS



Pending

## ACCESSORIES



**ACC, CMJ Models:**  
 Ceiling Plates .....pg# 190, 192



# PRSS Projector Mount

For Projectors up to 25lb (11kg)

## MODELS

### Universal Models:

Includes theft resistant hardware for attaching projector to mount  
**PRSS-UNV** Black

## PROJECTOR ADAPTER

### Mounting Pattern

Universal Models: Up to 17.63" (448mm)

## SPECIFICATIONS

### Tilt | Swivel | Roll

+15°/-20° | 360° | ±5°

### Max Load

25lb (11kg)

### Product Dimensions (W x H x D)

8.50"-17.63" x 3.60"-4.60"  
 x 8.50"-17.63"  
 (216-448 x 92-118 x 216-448mm)

### Mounting Surfaces

Wood joist, concrete  
 and other structures  
 (Other structures require accessory)

### Ship Weight

4.7lb (2kg)

## CERTIFICATIONS



Pending

## ACCESSORIES



**ACC, CMJ Models:**  
 Ceiling Plates ..... pg# 190, 192



**AEC, ALU and EXT Models:**  
 Extension Columns ..... pg# 152



**PWA-14(S)(W):**  
 Projector Wall Arm ..... pg# 195



**EX Models:**  
 Ceiling/Wall Extension Kits ... pg# 194

1. Spider® Universal Adapter Plate extends up to 17.63" (448mm) to fit most projector models
2. Low profile design allows projector to be flush with the ceiling
3. Cable management allows cables to be routed through projector mount and out of sight
4. Three axes of adjustments enable precise image aligning
5. Quick release mechanism to easily service projector
6. Pre-installed security screws provide optional tilt and roll lock to prevent tampering and adjustments



Patent Pending

## TECHNICAL DRAWINGS

For expanded product information and technical data visit [www.peerless-av.com](http://www.peerless-av.com)

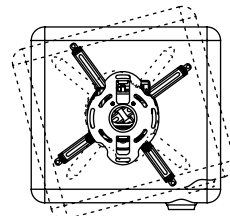
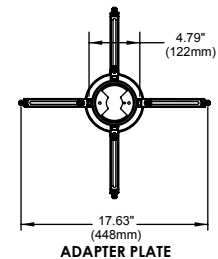
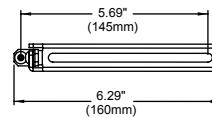
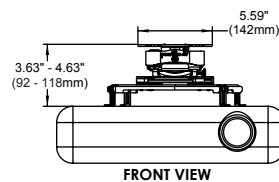

SWIVEL (YAW) 360° (when attached to extension column)  
 +/- 15° (when flush mounted)

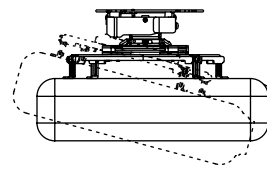

+15/- 20° PITCH

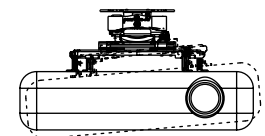

+/- 5° ROLL

To verify mount compatibility with any flat panel display or projector model use MountFinder™ at [www.peerless-av.com](http://www.peerless-av.com)



CALL: 630-375-5100  
 800-865-2112



FAX: 630-820-8537  
 800-359-6500



E-MAIL:  
[info@peerless-av.com](mailto:info@peerless-av.com)



ONLINE:  
[www.peerless-av.com](http://www.peerless-av.com)

# PRSS Adjustable Projector Mount Kit

For Projectors up to 25lb (11kg)

1. Spider® Universal Adapter Plate extends up to 17.63" (448mm) to fit most projector models
2. 1-1/2" x 11.5 NPT (38mm) adjustment column comes in three adjustment height ranges in 1" (25mm) increments:  
6"-9" (152-229mm)  
12"-18" (305-457mm)  
18"-24" (457-610mm)
3. Keep cables out of sight by routing them through the projector mount and extension column
4. Three axes of adjustments enable precise image alignment
5. Quick release mechanism to easily service projector
6. Pre-installed security screws provide optional tilt and roll lock to prevent tampering and adjustments

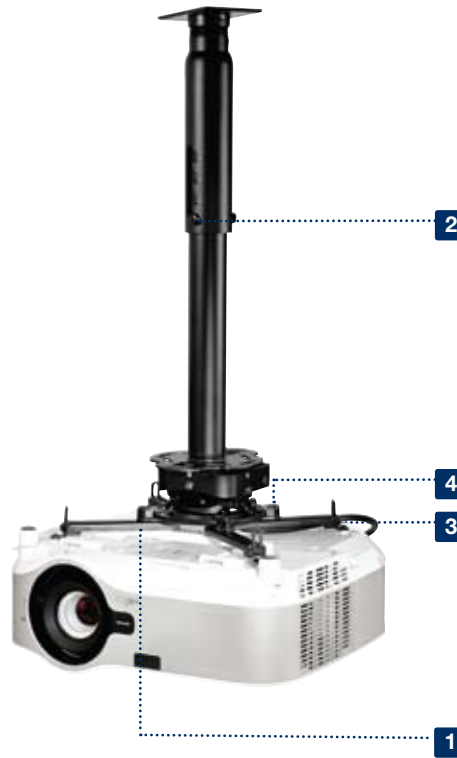

Patent Pending

For expanded product information and technical data visit [www.peerless-av.com](http://www.peerless-av.com)

## TECHNICAL DRAWINGS

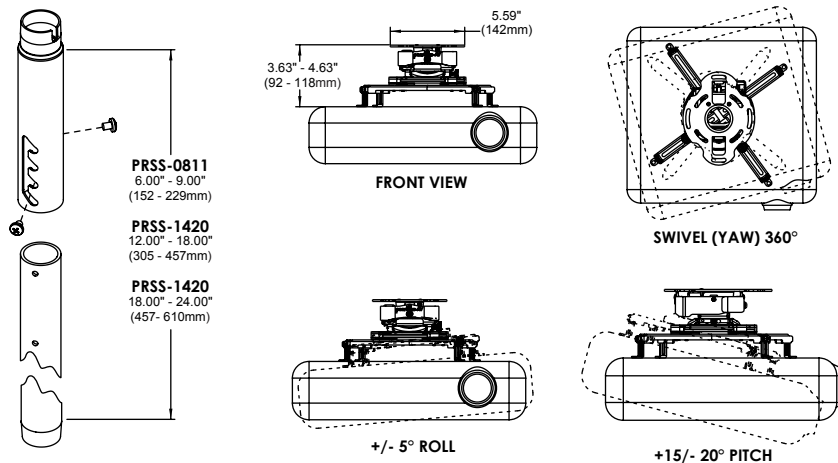

To verify mount compatibility with any flat panel display or projector model use MountFinder™ at [www.peerless-av.com](http://www.peerless-av.com)



CALL: 630-375-5100  
800-865-2112



FAX: 630-820-8537  
800-359-6500



E-MAIL: [info@peerless-av.com](mailto:info@peerless-av.com)



ONLINE: [www.peerless-av.com](http://www.peerless-av.com)



PROJECTOR &  
WHITEBOARD  
MOUNTS

## MODELS

### Universal Models:

Includes theft resistant hardware for attaching projector to mount

Kitted with Aluminum Adjustable Extension Column:

**PRSS-ALU0811** Black

**PRSS-ALU1420** Black

**PRSS-ALU2026** Black

Kitted with Steel Adjustable Extension Column:

**PRSS-KIT0811** Black

**PRSS-KIT1420** Black

**PRSS-KIT2026** Black

## PROJECTOR ADAPTER



### Mounting Pattern

Universal Models: Up to 17.63" (448mm)

## SPECIFICATIONS



### Distance from Ceiling

PRSS-ALU/KIT0811: 6"-9" (152-229mm)

PRSS-ALU/KIT1420: 12"-18" (305-457mm)

PRSS-ALU/KIT2026: 18"-24" (457-610mm)



### Tilt | Swivel | Roll

+15°/-20° | 360° | ±5°



### Max Load

25lb (11kg)



### Product Dimensions (W x D)

8.50"-17.63" x 8.50"-17.63"  
(216-448 x 216-448mm)

### Mounting Surfaces

Wood joist, concrete  
and other structures  
(Other structures require accessory)

### Ship Weight

PRSS-ALU0811: 6lb (2kg)

PRSS-ALU1420: 8.9lb (4kg)

PRSS-ALU2026: 9.6lb (4kg)

PRSS-KIT0811: 8.6lb (4kg)

PRSS-KIT1420: 10.3lb (5kg)

PRSS-KIT2026: 13.7lb (6kg)

## CERTIFICATIONS



RoHS

MADE IN USA

Pending

## ACCESSORIES



### ACC, CMJ Models:

Ceiling Plates .....pg# 190, 192



# PAG Projector Mount

For Projectors up to 25lb (11.3kg) and 50lb (22kg)

## MODELS

### Universal Models:

Includes theft resistant hardware for attaching projector to mount  
**PAG-UNV-MU** For up to 25lb (11.3kg) Black  
**PAG-UNV** For up to 50lb (22kg) Black

### Dedicated Models:

Projector adapter purchased separately\*  
**PAG-MU** For up to 25lb (11.3kg) Black

\* Dedicated adapter plates come in flat black and include security fasteners

## PROJECTOR ADAPTER

### Mounting Pattern

**Universal Models:** Up to 17.63" (448mm)  
**Dedicated Models:** Requires projector specific adapter plate to be purchased separately.

## SPECIFICATIONS

### Tilt | Swivel | Roll

±45° | 360° | ±45°

### Max Load

**PAG-MU:** 25lb (11.3kg)  
**PAG-UNV-MU:** 25lb (11.3kg)  
**PAG-UNV:** 50lb (22kg)

### Product Dimensions (W x H x D)

**PAG-MU:** 3.25" x 3.29" x 2.25"  
 (82.55 x 83.5 x 57.15mm)  
**PAG-UNV-MU:** 8.50"-17.63" x 4.29"-5.29" x 8.50"-17.63"  
 (216-448 x 109-134 x 216-448mm)  
**PAG-UNV:** 8.50"-17.63" x 4.50"-7.14" x 8.50"-17.63"  
 (216-448 x 114-181 x 216-448mm)

### Mounting Surfaces

Wood joist, concrete and other structures  
 (Other structures require accessory)

### Ship Weight

**PAG-MU:** 0.86lb (0.39kg)  
**PAG-UNV-MU:** 2.62lb (1.18kg)  
**PAG-UNV:** 5lb (2.27kg)

## CERTIFICATIONS



## ACCESSORIES



**ACC, CMJ Models:**  
 Ceiling Plates ..... pg# 190, 192



**AEC, ALU and EXT Models:**  
 Extension Columns ..... pg# 152



**PWA-14(S)(W):**  
 Projector Wall Arm ..... pg# 195



**EX Models:**  
 Ceiling/Wall Extension Kits ..... pg# 194

- Spider® Universal Adapter Plate extends up to 17.63" (488mm) to fit most projector models
- Patented gear technology enables effortless adjustment to achieve precise image alignment
- No tools required for image alignment, dual knob design provides hassle-free method for adjusting the gears
- Cable management system, with use of extension column, allows for cable routing straight through the mount to keep the projector cables secure and out of sight
- Quick-release mechanism to easily service projector

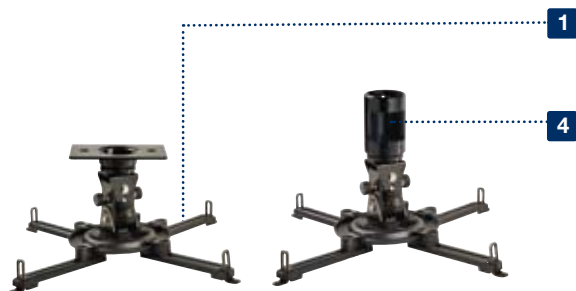

Patented

## TECHNICAL DRAWINGS

For expanded product information and technical data visit [www.peerless-av.com](http://www.peerless-av.com)

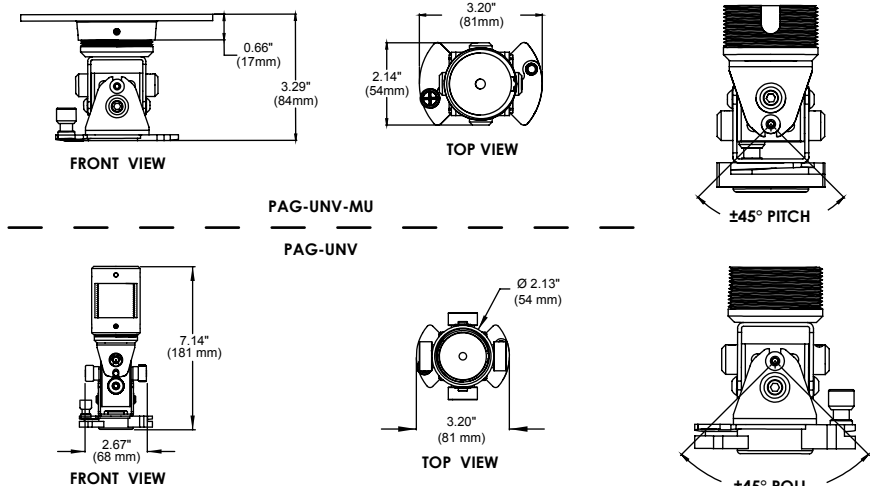

To verify mount compatibility with any flat panel display or projector model use MountFinder™ at [www.peerless-av.com](http://www.peerless-av.com)



CALL: 630-375-5100  
800-865-2112



FAX: 630-820-8537  
800-359-6500



E-MAIL: [info@peerless-av.com](mailto:info@peerless-av.com)



ONLINE: [www.peerless-av.com](http://www.peerless-av.com)

# PAG Heavy Duty Projector Mount

For Projectors up to 100lb (45kg) and 130lb (59kg)

1. Spider® Universal Adapter Plate extends up 17.63" (448mm) to fit most projector models
2. Patented gear technology enables effortless adjustment to achieve precise image alignment
3. No tools required for image alignment, dual knob design provides hassle-free method for adjusting the gears
4. Cable management system, with use of extension column, allows for cable routing straight through the mount to keep the projector cables secure and out of sight
5. Quick-release mechanism to easily service projector



Patented

For expanded product information and technical data visit [www.peerless-av.com](http://www.peerless-av.com)

## TECHNICAL DRAWINGS

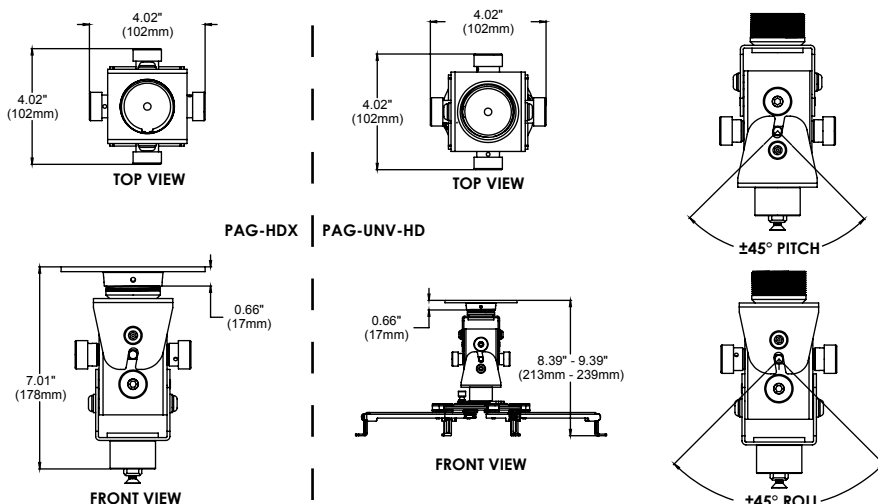

To verify mount compatibility with any flat panel display or projector model use MountFinder™ at [www.peerless-av.com](http://www.peerless-av.com)



CALL: 630-375-5100  
800-865-2112



FAX: 630-820-8537  
800-359-6500



E-MAIL: [info@peerless-av.com](mailto:info@peerless-av.com)



ONLINE: [www.peerless-av.com](http://www.peerless-av.com)



PROJECTOR &  
WHITEBOARD  
MOUNTS

## MODELS

### Universal Models:

Includes theft resistant hardware for attaching projector to mount  
**PAG-UNV-HD** For up to 100lb (45kg) Black

### Dedicated Models:

Projector adapter purchased separately\*  
**PAG-HDX** For up to 125lb (56kg) Black

\*Dedicated adapter plates come in flat black and include security fasteners

## PROJECTOR ADAPTER



### Mounting Pattern

Universal Models: Up to 17.63" (448mm)

Dedicated Models: Requires projector specific adapter plate to be purchased separately.

## SPECIFICATIONS



### Tilt | Swivel | Roll

±45° | 360° | ±45°



### Max Load

PAG-UNV-HD: 100lb (45kg)  
PAG-HDX: 130lb (59kg)

### Product Dimensions (W x H x D)

PAG-UNV-HD: 8.50"-17.63" x 8.39"-9.39"  
(216-448 x 213-239 x 216-448mm)  
PAG-HDX: 5.00" x 7.01" x 3.00"  
(76 x 178 x 127mm)

### Mounting Surfaces

Wood joist, concrete and other structures  
(Other structures require accessory)

### Ship Weight

PAG-UNV-HD: 6.2lb (2.81kg)  
PAG-HDX: 4.8lb (2.1kg)

## CERTIFICATIONS



## ACCESSORIES



**ACC, CMJ Models:**  
Ceiling Plates .....pg# 190, 192



**AEC, ALU and EXT Models:**  
Extension Columns ..... pg# 152



**PWA-14(S)(W):**  
Projector Wall Arm ..... pg# 195



**EX Models:**  
Ceiling/Wall Extension Kits ..... pg# 194





# Flush Ceiling Projector Mount

For Projectors up to 50lb (22kg)

## MODELS

### Universal Models:

Includes theft resistant hardware for attaching projector to mount

<b>PPF</b>	Black
<b>PPF-S</b>	Silver
<b>PPF-W</b>	White

## PROJECTOR ADAPTER

### Mounting Pattern

Universal Models: Up to 17.63" (448mm)

## SPECIFICATIONS

### Tilt | Swivel | Roll

+30°/-5° | ±20° | ±20°

### Max Load

50lb (22kg)

### Product Dimensions (W x H x D)

8.50"-17.63" x 6.83"-7.83" x  
8.50"-17.63"  
(216-448 x 173-199 x 216-448mm)

### Mounting Surfaces

Wood joist, concrete

### Ship Weight

4.8lb (2.17kg)

## CERTIFICATIONS



1. Spider® Universal Adapter Plate extends up 17.63" (488mm) to fit most projector models
2. Provides full range of image adjustment
3. Low-profile design for flush mount installations



Patented

## TECHNICAL DRAWINGS

For expanded product information and technical data visit [www.peerless-av.com](http://www.peerless-av.com)

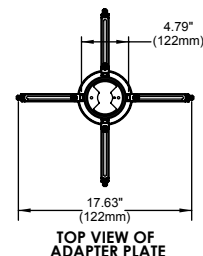
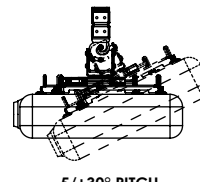
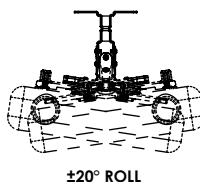
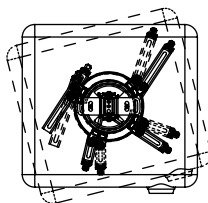
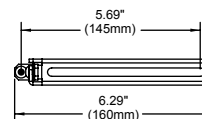
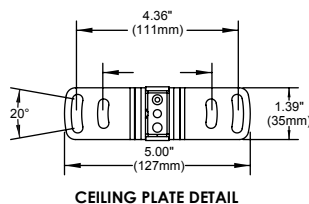
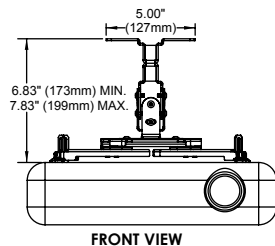

To verify mount compatibility with any flat panel display or projector model use MountFinder™ at [www.peerless-av.com](http://www.peerless-av.com)



# Adjustable Ceiling/Wall Projector Mount

For Projectors up to 50lb (22kg)



PROJECTOR & WHITEBOARD MOUNTS

- Spider® Universal Adapter Plate extends up to 17.63" (448mm) to fit most projector models
- Mounts to ceiling or wall\* with included wall mount interface  
\* PPA and PPB models only. PPC is not wall mountable due to its extensive reach.
- Works with standard 4" (101mm) loops for use with round, square, rectangular or I-Beam truss up to 3" (76mm) wide x 3.5" (89mm) wide
- Continuous channel design for uninterrupted drop length or wall extension adjustments
- Safety catch designed into extension to ensure user and equipment safety
- Internal cable management within channels for clean, clutter-free appearance



Patented

For expanded product information and technical data visit [www.peerless-av.com](http://www.peerless-av.com)

## TECHNICAL DRAWINGS

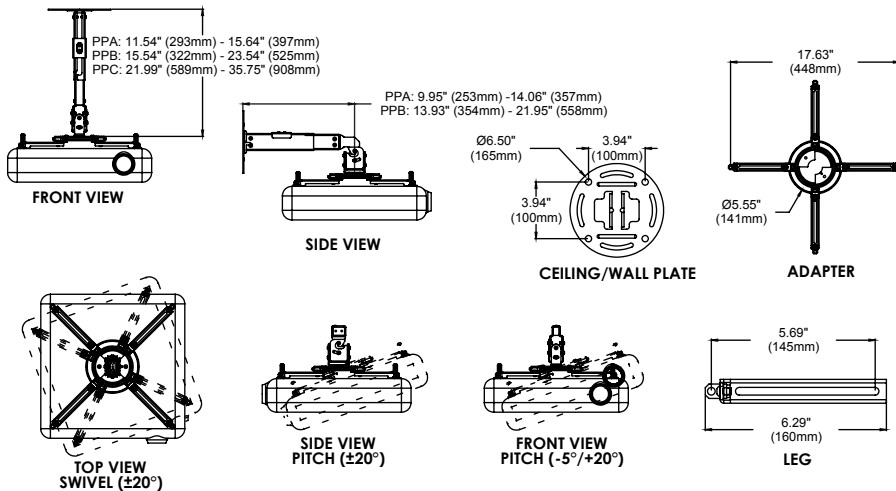

## MODELS

### Universal Models:

Includes theft resistant hardware for attaching projector to mount

With 11.54"-15.64" (293-397mm) ceiling extension and 9.95"-14.06" (253-357mm) wall extension:

**PPA** Black  
**PPA-S** Silver  
**PPA-W** White

With 15.54"-23.54" (322-525mm) ceiling extension and 13.93"-21.95" (354-558mm) wall extension:

**PPB** Black  
**PPB-S** Silver  
**PPB-W** White

With 21.99"-35.75" (589-908mm) ceiling extension:

**PPC** Black  
**PPC-S** Silver  
**PPC-W** White

## PROJECTOR ADAPTER



### Mounting Pattern

Universal Models: Up to 17.63" (448mm)

## SPECIFICATIONS



### Distance from Ceiling

PPA(-S)(-W): 11.54"-15.64" (293-397mm)  
PPB(-S)(-W): 15.54"-23.54" (322-525mm)  
PPC(-S)(-W): 21.99"-35.75" (589-908mm)



### Distance from Wall

PPA(-S)(-W): 9.95"-14.06" (253-357mm)  
PPB(-S)(-W): 13.93"-21.95" (354-558mm)



### Tilt | Swivel | Roll

+30°/-5° |  
360° (±20° at mount) | ±20°



### Max Load

50lb (22kg)

### Product Dimensions (W x D)

8.50"-17.63" x 8.50"-17.63"  
(216-448 x 216-448mm)

### Mounting Surfaces

Wood joist, concrete and truss

### Ship Weight

PPA(-S)(-W): 6.4lb (2.90kg)  
PPB(-S)(-W): 6.8lb (3.08kg)  
PPC(-S)(-W): 7.7lb (3.49kg)

## CERTIFICATIONS



## ACCESSORIES



**ACC575:**  
Threaded Connector  
Accessory.....pg# 193

To verify mount compatibility with any flat panel display or projector model use MountFinder™ at [www.peerless-av.com](http://www.peerless-av.com)



CALL: 630-375-5100  
800-865-2112



FAX: 630-820-8537  
800-359-6500



E-MAIL:  
[info@peerless-av.com](mailto:info@peerless-av.com)



ONLINE:  
[www.peerless-av.com](http://www.peerless-av.com)



# PSM / PSMU Security Projector Mounts

For Projectors up to 50lb (22kg)

## MODELS

### Universal PSM-UNV Models:

Includes theft resistant hardware for attaching projector to mount

<b>PSM-UNV</b>	Black
<b>PSM-UNV-S</b>	Silver
<b>PSM-UNV-W</b>	White

### Universal PSMU-PRS Models:

Includes theft resistant hardware for attaching projector to mount

<b>PSMU-PRS</b>	Black
<b>PSMU-PRS-S</b>	Silver
<b>PSMU-PRS-W</b>	White

## PROJECTOR ADAPTER



### Mounting Pattern

Universal tray pattern accommodates most projectors.

## SPECIFICATIONS



### Tilt | Swivel | Roll

<b>PSM-UNV Models:</b>	±15°   360°   ±15°
<b>PSMU-PRS Models:</b>	+5/-20°   360°   ±10°



### Max Load

<b>PSM-UNV Models:</b>	50lb (22kg)
<b>PSMU-PRS Models:</b>	25lb (11kg)

### Product Dimensions (W x H x D)

<b>PSM-UNV Models:</b>	14.25" x 4.67" x 12.82" (362 x 119 x 326mm)
<b>PSMU-PRS Models:</b>	14.25" x 3.86" x 12.82" (362 x 98 x 326mm)

### Mounting Surfaces

Wood joist, concrete and other structures  
(Other structures require accessory)

### Ship Weight

<b>PSM-UNV Models:</b>	10.4lb (4.7kg)
<b>PSMU-PRS Models:</b>	11.5lb (5.2kg)

## CERTIFICATIONS



## ACCESSORIES



**ACC, CMJ Models:**  
Ceiling Plates .....pg# 190, 192



**AEC, ALU and EXT Models:**  
Extension Columns ..... pg# 152



**PWA-14(S)(W):**  
Projector Wall Arm ..... pg# 195



**ACC810:**  
Threaded Rod Adapter ..... pg# 194

1. Key-lock security for theft deterrence
2. Two-piece tray design prevents access to security fasteners
3. Easy-access hinge design for quick projector removal, enabling lamp and filter maintenance
4. Top access hole for cable management
5. Mount and security fasteners included

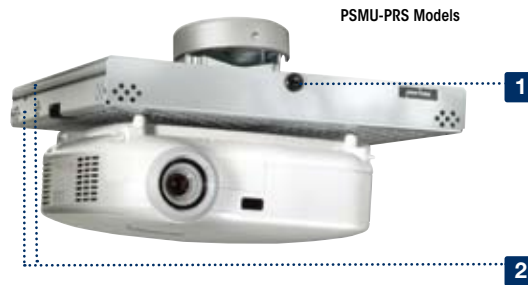

PSMU-PRS Models



PSM-UNV Models

Patented

## TECHNICAL DRAWINGS

For expanded product information and technical data visit [www.peerless-av.com](http://www.peerless-av.com)

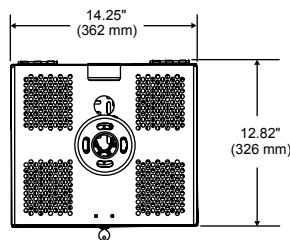

PSMU-PRS

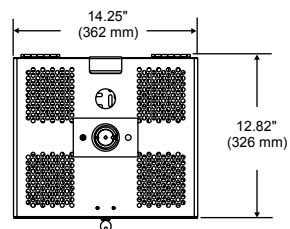

PSM-UNV

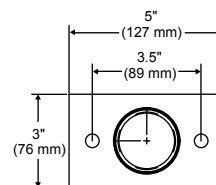

To verify mount compatibility with any flat panel display or projector model use MountFinder™ at [www.peerless-av.com](http://www.peerless-av.com)

# Projector Enclosure

For use with Peerless-AV™ Projector Mounts



PROJECTOR &  
WHITEBOARD  
MOUNTS

1. Secures and protects virtually any projector and mount
2. Retro-fit capable without tampering with existing installations
3. Adjustable bars accommodate projector lens placement
4. Pipe clamp accommodates 1" (25mm) NPT to 1.5" (38mm) NPT pipe
5. Hook-n-Hang design allows hands-free operation during projector installation or maintenance
6. Can also be flush mounted to position projector close to ceiling

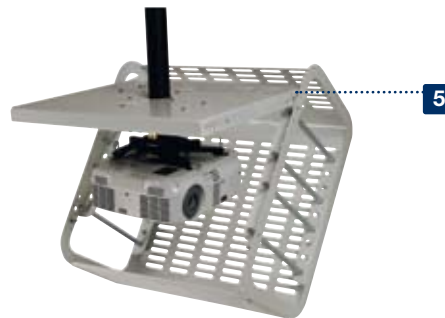
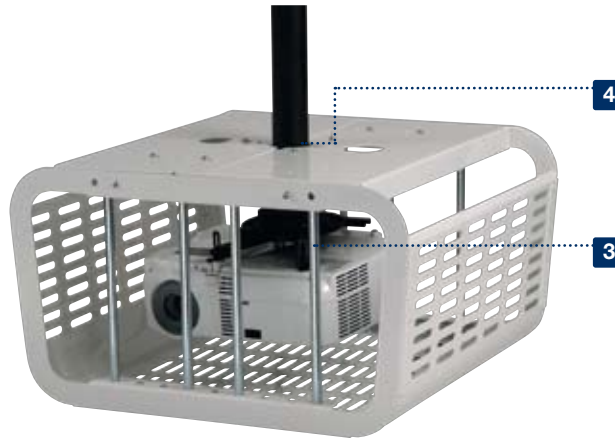

## MODELS

### Universal Models:

Includes theft resistant hardware for attaching projector to mount

<b>PE1120</b>	Black
<b>PE1120-W</b>	White

## SPECIFICATIONS



### Product Dimensions (W x H x D)

22.41" x 12.57" x 20.53"  
(569 x 319 x 521mm)

### Mounting Surfaces

Attaches to 1"-1.5" NPT pipe or can be attached directly to structural or suspended ceiling (Suspended ceiling requires accessory)

### Ship Weight

43.5lb (19.8kg)

## CERTIFICATIONS



## ACCESSORIES



**PRG, PRS, PAG, PJF2 Models:**  
Projector Mounts ..... pg# 135-146



**AEC, ALU and EXT Models:**  
Extension Columns ..... pg# 152



**CMJ450/453/455/500 Models:**  
Suspended Ceiling  
Accessory ..... pg# 192

For expanded product information and technical data visit [www.peerless-av.com](http://www.peerless-av.com)

## TECHNICAL DRAWINGS

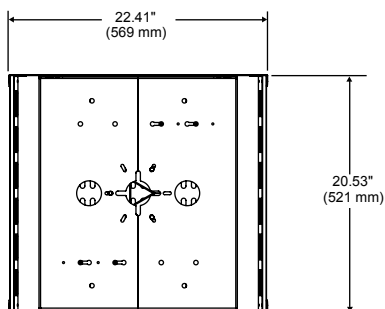

TOP VIEW

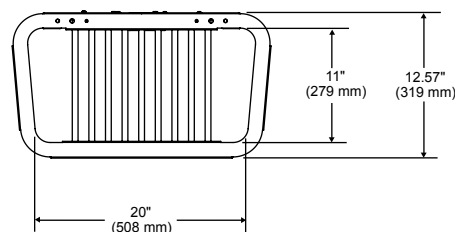

FRONT VIEW

To verify mount compatibility with any flat panel display or projector model use MountFinder™ at [www.peerless-av.com](http://www.peerless-av.com)



CALL: 630-375-5100  
800-865-2112



FAX: 630-820-8537  
800-359-6500



E-MAIL:  
[info@peerless-av.com](mailto:info@peerless-av.com)



ONLINE:  
[www.peerless-av.com](http://www.peerless-av.com)



# Adjustable and Fixed Extension Columns

For up to 1200lb (544kg)

## MODELS

Includes standard hardware (hex or Phillips) for attaching whiteboard to mount

### Adjustable Aluminum Models:

**ALU models** Black, silver or white

### Adjustable Steel Models:

**AEC models** Black, silver or white

### Fixed Steel Models:

**EXT models** Black or silver

## SPECIFICATIONS

	<b>Distance from Ceiling</b>	See chart
	<b>Max Load</b>	
	<b>ALU Models:</b>	500lb (227kg)
	<b>AEC Models:</b>	900lb (408kg)
	<b>EXT Models:</b>	1200lb (544kg)
	<b>Ship Weight</b>	See chart

- 1.5" x 11.5 NPT (38mm) schedule 40 pipe, threaded on both ends
- ALU models made of lightweight aluminum for easy installation and lower-cost shipping
- Height adjustable at 1" (25mm) increments for ALU and AEC models
- Locking slot design enables easy, flexible height adjustment
- Extension column lengths measure 1" (25mm) longer than stated drop to provide finished drop lengths for various mounts
- Notch design at the top for a set screw to lock the column in place



EXT Models

### ALU/AEC Models

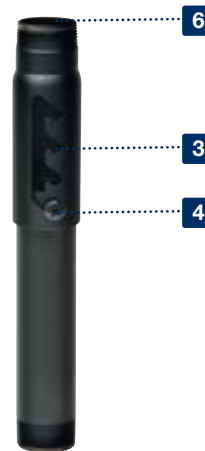

## CERTIFICATIONS



## ACCESSORIES



**ACC, CMJ Models:**  
Ceiling Plates .....pg# 190, 192



**ACC640(-B)(-W):**  
Escutcheon Ring.....pg# 194



**ACC109:**  
Extension Column  
Connector .....pg# 193

## TECHNICAL DRAWINGS

For expanded product information and technical data visit [www.peerless-av.com](http://www.peerless-av.com)

Model	Drop Length (X)	Ship Weight
<b>Adjustable Aluminum Models:</b>		
ALU006009(-S)(-W)	6'-9" (0.15-0.23m)	1.3lb (0.6kg)
ALU0090012(-S)(-W)	9'-12" (0.22-0.30m)	1.6lb (0.7kg)
ALU012018(-S)(-W)	12'-18" (0.30-0.46m)	2.2lb (1kg)
ALU018024(-S)(-W)	18"-24" (0.46-0.61m)	2.9lb (1.3kg)
ALU0203(-S)(-W)	2'-3' (0.61-0.91m)	4.1lb (1.9kg)
ALU0305(-S)(-W)	3'-5' (0.91-1.52m)	6.7lb (3.0kg)
ALU0406(-S)(-W)	4'-6" (1.22-1.83m)	9.1lb (4.1kg)
ALU0507(-S)(-W)	5'-7" (1.52-2.13m)	10.4lb (4.7kg)
ALU0608(-S)(-W)	6'-8" (1.83-2.44m)	11.4lb (5.2kg)
ALU0810(-S)(-W)	8'-10" (2.44-3.05m)	13.9lb (6.3kg)
ALU1012(-S)(-W)	10'-12" (3.05-3.66m)	16.0lb (7.3kg)
<b>Adjustable Steel Models:</b>		
AEC006009(-S)(-W)	6'-9" (0.15-0.23m)	2.16lb (0.98kg)
AEC012018(-S)(-W)	12'-18" (0.30-0.46m)	3.98lb (1.80kg)
AEC018024(-S)(-W)	18"-24" (0.46-0.61m)	5.72lb (2.59kg)
AEC0203(-S)(-W)	2'-3' (0.61-0.91m)	7.87lb (3.57kg)
AEC0305(-S)(-W)	3'-5' (0.91-1.52m)	13.01lb (5.90kg)
AEC0406(-S)(-W)	4'-6" (1.22-1.83m)	16.53lb (7.49kg)
AEC0608(-S)(-W)	6'-8" (1.83-2.44m)	22.47lb (10.19kg)
AEC0810(-S)(-W)	8'-10" (2.44-3.05m)	28.42lb (12.89kg)
AEC1012(-S)(-W)	10'-12" (3.05-3.66m)	34.25lb (15.53kg)
<b>Fixed Steel Models:</b>		
EXT002(S)	Flush	1lb (0.4kg)
EXT006(S)	6" (15cm)	2.3lb (1kg)
EXT018(S)	18" (46cm)	4lb (1.8kg)
EXT101(S)	1' (0.3m)	3.7lb (1.7kg)
EXT102(S)	2' (0.6m)	6lb (2.7kg)
EXT103(S)	3' (0.9m)	9lb (4.1kg)
EXT104(S)	4' (1.2m)	10lb (4.5kg)
EXT105(S)	5' (1.5m)	15lb (6.8kg)
EXT106(S)	6' (1.8m)	16lb (7.3kg)
EXT107(S)	7' (2.1m)	18lb (8.2kg)
EXT108(S)	8' (2.4m)	20lb (9.1kg)
EXT109(S)	9' (2.7m)	26lb (11.8kg)
EXT110(S)	10' (3.1m)	29lb (13.2kg)

### ALU/AEC Models

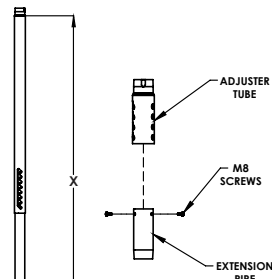

### EXT Models

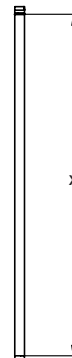

To verify mount compatibility with any flat panel display or projector model use MountFinder™ at [www.peerless-av.com](http://www.peerless-av.com)



# Short Throw Projector Mount

For Projectors up to 25lb (11kg)

1. Aluminum alloy telescoping arm with lock down slot
2. Fully integrated cable management system conceals and protects cables for a clean finish
3. Three models and three different lengths to cover all short throw projectors
4. Includes PRGS-UNV projector mount with precision gear alignment and adjustment knobs to control tilt and roll alignment
5. Wall plate with 10" (254mm) of lateral shift and 6" (152mm) of horizontal lift with PSTK models

PSTA models

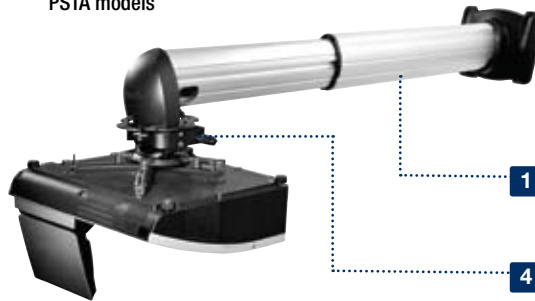

PSTK models

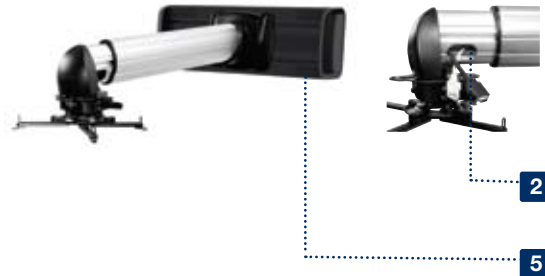

Patented

For expanded product information and technical data visit [www.peerless-av.com](http://www.peerless-av.com)

## TECHNICAL DRAWINGS

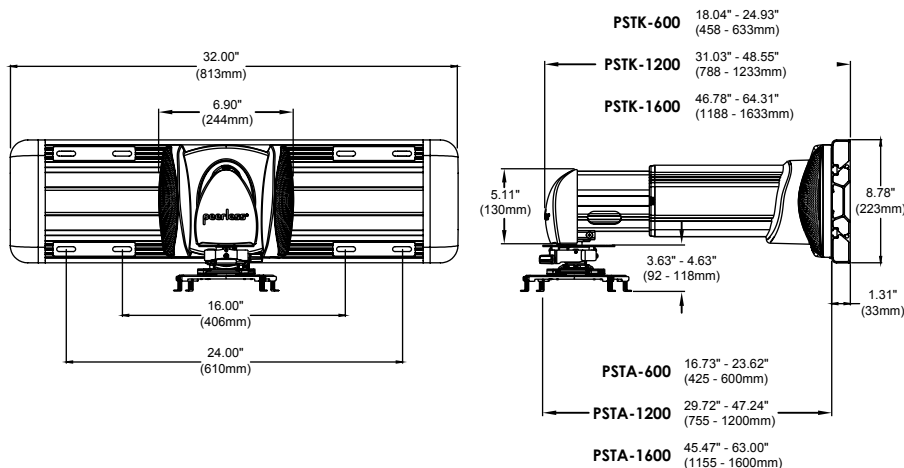

PROJECTOR & WHITEBOARD MOUNTS

## MODELS

### Universal Models:

Includes theft resistant hardware for attaching projector to mount

With 23.62" (600mm) wall extension:  
**PSTA-600** Black/ silver  
**PSTK-600** Black/ silver with wall plate

With 47.20" (1200mm) wall extension:  
**PSTA-1200** Black/ silver  
**PSTK-1200** Black/ silver with wall plate

With 63.00" (1600mm) wall extension:  
**PSTA-1600** Black/ silver  
**PSTK-1600** Black/ silver with wall plate

## PROJECTOR ADAPTER



### Mounting Pattern

Universal Models: Up to 17.63" (448mm)

## SPECIFICATIONS



### Distance from Wall

**PSTA/PSTK-600:** 23.62" (600mm)  
**PSTA/PSTK-1200:** 47.20" (1200mm)  
**PSTA/PSTK-1600:** 63.00" (1600mm)



### Tilt | Swivel | Roll

+5°/-20° | 360° | ±5°



### Max Load

40lb (18kg)

### Product Dimensions (W x H x D)

**PSTA-600:** 25.00" x 9.60" x 10.60"  
(635 x 244 x 271mm)  
**PSTK-600:** 25.00" x 9.60" x 12.00"  
(635 x 244 x 308mm)  
**PSTA-1200:** 48.60" x 9.60" x 10.60"  
(1235 x 244 x 271mm)  
**PSTK-1200:** 48.60" x 9.60" x 12.00"  
(1235 x 244 x 308mm)  
**PSTA-1600:** 64.30" x 9.60" x 10.60"  
(1635 x 244 x 271mm)  
**PSTK-1600:** 64.30" x 9.60" x 12.00"  
(1635 x 244 x 308mm)

### Mounting Surfaces

Wood, concrete and other structures  
(Other structures require accessory)

### Ship Weight

**PSTA-600:** 10.5lb (4.7kg)  
**PSTK-600:** 19.4lb (9kg)  
**PSTA-1200:** 14.5lb (6.5kg)  
**PSTK-1200:** 23.4lb (11kg)  
**PSTA-1600:** 17.5lb (7.9kg)  
**PSTK-1600:** 26.4lb (12kg)

## CERTIFICATIONS



## ACCESSORIES



**ACC215/415/615:**  
Metal Stud Fastener Kit ..... pg# 196



**IBA models:**  
In-wall boxes ..... pg# 197

To verify mount compatibility with any flat panel display or projector model use MountFinder™ at [www.peerless-av.com](http://www.peerless-av.com)



CALL: 630-375-5100  
800-865-2112



FAX: 630-820-8537  
800-359-6500



E-MAIL:  
[info@peerless-av.com](mailto:info@peerless-av.com)



ONLINE:  
[www.peerless-av.com](http://www.peerless-av.com)





# Universal Whiteboard Mount

For attaching over existing marker boards and chalkboards

## MODELS

### Universal Models:

Includes standard hardware (hex or Phillips) for attaching whiteboard to mount

**IWB600-UNIV** Silver

## WHITEBOARD ADAPTER

**Universal Models:** Infinite x 48.00"-76.00"  
(1219-1930mm)

**Dedicated Models Compatible with:**  
 64" SMART Board™ SB660  
 77" SMART Board™ SB680  
 77" SMART SBX880  
 77" Marsh Board PR4050000  
 63" Hitachi StarBoard® DUO  
 77" Hitachi StarBoard® DUO  
 77" Hitachi StarBoard® TRIO  
 88" Hitachi StarBoard® DUO  
 77" Interwrite DualBoard™ 1277  
 64" Promethean ActivBoard™ 164  
 78" Promethean ActivBoard™ 178  
 78" Promethean ActivBoard™ 378 PRO  
 87" Promethean ActivBoard™ 387 PRO  
 95" Promethean ActivBoard™ 395 PRO

## SPECIFICATIONS



### Distance from Wall

5.82"-7.35" (148-187mm)



### Max Load

70lb (32kg)

### Product Dimensions (H x D)

Each Rail: 48.00"-76.00" x 5.82"-7.35"  
(1219-1930 x 148-187mm)

### Mounting Surfaces

Wall

### Ship Weight

18.5lb (8.4kg)

## CERTIFICATIONS



## ACCESSORIES



### ACC956:

Adhesive Bumpers

Contact Peerless-AV™ Customer Care for more information

- Four individual clamps enable virtually any board up to 1.75" (45mm) thick to be easily mounted
- Telescoping vertical rails allow the mount to accommodate existing boards up to 76.00" (1930mm) tall
- Mounts over virtually any existing chalk-board, even boards with chalkboard trays, by quickly and easily adjusting the mounts depth
- Unique design allows for universal compatibility via adjustable bezel clamps and dedicated mounting hole patterns for industry leading whiteboards
- Some whiteboards may require bumpers, ACC956, to be added between the mount and the board in order to make the board more rigid

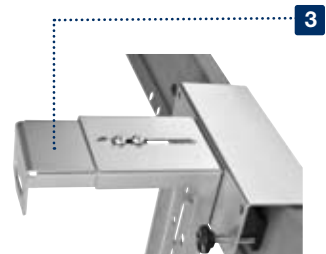
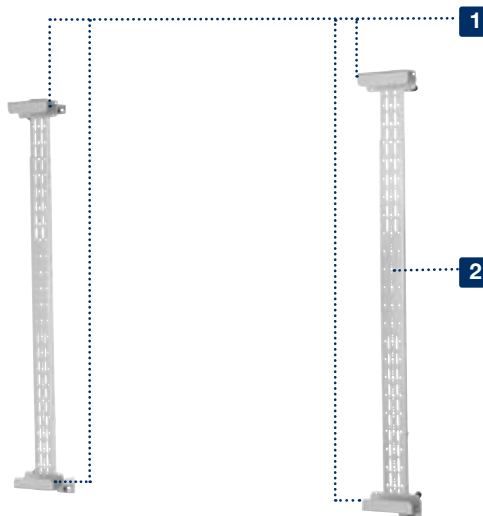

Patented

## TECHNICAL DRAWINGS

For expanded product information and technical data visit [www.peerless-av.com](http://www.peerless-av.com)

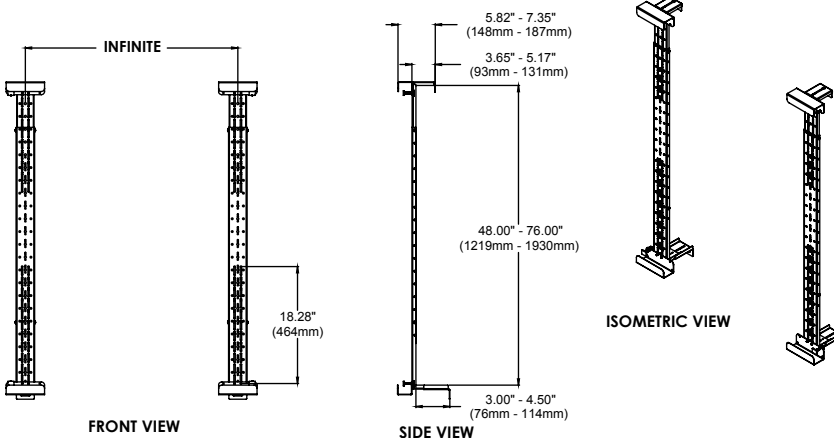

To verify mount compatibility with any flat panel display or projector model use MountFinder™ at [www.peerless-av.com](http://www.peerless-av.com)



CALL: 630-375-5100  
800-865-2112



FAX: 630-820-8537  
800-359-6500



E-MAIL:  
[info@peerless-av.com](mailto:info@peerless-av.com)



ONLINE:  
[www.peerless-av.com](http://www.peerless-av.com)



# Dedicated Whiteboard Mount

For attaching over existing marker boards and chalkboards



1. Mounts over the existing marker board/chalkboard with depth adjustable wall brackets
2. Vertical and horizontal whiteboard adjustment
3. Hook-on design allows for single person installation
4. Some boards may require bumpers, ACC956, to be added between the mount and the board in order to make the board more rigid

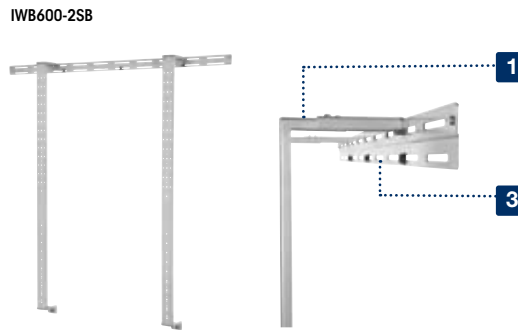

Patented

For expanded product information and technical data visit [www.peerless-av.com](http://www.peerless-av.com)

## TECHNICAL DRAWINGS

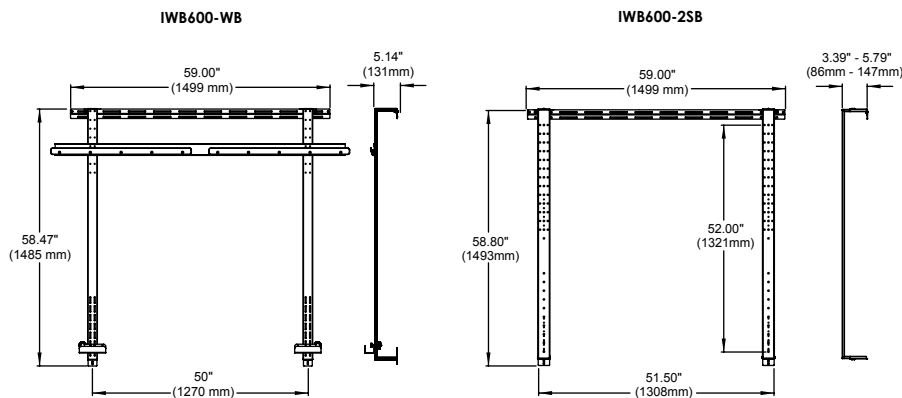

## MODELS

### Dedicated Models:

Includes standard hardware (hex or Phillips) for attaching whiteboard to mount



<b>IWB600-WB</b>	Silver
<b>IWB600-2SB</b>	Silver

## WHITEBOARD ADAPTER

Dedicated Models  
Compatible with:

<b>IWB600-WB:</b>	SMART Board™ 600, 600i, 685ix, 800, 800i and 885ix
<b>IWB600-2SB:</b>	64" SMART Board™ SB660 77" SMART Board™ SB680 77" Marsh Board PR4050000 63" Hitachi StarBoard® DUO 77" Hitachi StarBoard® DUO 77" Hitachi StarBoard® TRIO 88" Hitachi StarBoard® DUO 77" Interwrite DualBoard™ 1277 64" Promethean ActivBoard™ 164 78" Promethean ActivBoard™ 178 78" Promethean ActivBoard™ 378 PRO 87" Promethean ActivBoard™ 387 PRO 95" Promethean ActivBoard™ 395 PRO

## SPECIFICATIONS

	<b>Distance from Wall</b>
<b>IWB600-WB:</b>	4.59"-5.14" (117-131mm)
<b>IWB600-2SB:</b>	3.39"-5.79" (86-147mm)
	<b>Max Load</b>
<b>IWB600-WB:</b>	50lb (22kg)
<b>IWB600-2SB:</b>	70lb (32kg)
<b>Product Dimensions (W x H x D)</b>	
<b>IWB600-WB:</b>	68.00" x 58.47" x 4.59"-5.14" (1727 x 1485 x 117-131mm)
<b>IWB600-2SB:</b>	59.00" x 58.80" x 3.39"-5.79" (1499 x 1493 x 86-147mm)
<b>Mounting Surfaces</b>	
Wall	
<b>Ship Weight</b>	
<b>IWB600-WB:</b>	23lb (10.4kg)
<b>IWB600-2SB:</b>	19.5lb (8.8kg)

## CERTIFICATIONS



## ACCESSORIES



**ACC956:**  
Adhesive Bumpers  
Contact Peerless-AV™ Customer Care for more information

To verify mount compatibility with any flat panel display or projector model use MountFinder™ at [www.peerless-av.com](http://www.peerless-av.com)



**CALL:** 630-375-5100  
800-865-2112



**FAX:** 630-820-8537  
800-359-6500



**E-MAIL:**  
[info@peerless-av.com](mailto:info@peerless-av.com)



**ONLINE:**  
[www.peerless-av.com](http://www.peerless-av.com)



## AV ACCESSORIES TABLE OF CONTENTS

Cables	<b>DEW-HD05/DEB-HD10/DEB-HD15/DEB-HD20</b> High Speed HDMI® Cables with Ethernet Type A Connectors ..... pg# 157
	<b>SLW-HDRU05/SLW-HDRZ05</b> High Speed HDMI® Cables with Ethernet For Rear and Side Mounted Connectors ..... pg# 158
	<b>DEB-CV05/DEB-CV10/DEB-CV15/DEB-CV20</b> High Performance Component Video Cable 3xRCA plugs to 3xRCA plugs..... pg# 159
	<b>DEW-RR05/DEB-RR10/DEB-RR15/DEB-RR20</b> Stereo High Performance Audio Cable 2xRCA plugs to 2xRCA plugs..... pg# 160
	<b>DEW-JR05</b> Portable Stereo Audio Cable 3.5mm jack plug to 2xRCA plugs..... pg# 161
	<b>DEW-JJ05</b> Portable Stereo Audio Cable 3.5mm jack plug to 3.5mm jack plug ..... pg# 162
	<b>PCC Models</b> Cable Management Channel for Cables ..... pg# 163
	<b>AVM Model</b> 15U AV Component Rack System Compatible with most standard 19" rack accessories ..... pg# 164
	<b>AVL Model</b> 30U AV Component Rack System Compatible with most standard 19" rack accessories ..... pg# 165
	<b>ACC309 Model</b> Video Conference Shelf for Video Conference Equipment ..... pg# 166
<b>PS200 Model</b> Adjustable Shelf for AV Components ..... pg# 167	
Cable Management Channels AV Component Rack Systems AV Shelves	<b>VPM/DS Models</b> Adjustable AV Component Shelves for Most AV Components ..... pg# 168
	<b>ACC931/ACC932/ACC951 Models</b> AV Component Shelf Accessory Brackets for Articulating, Pivot and Ceiling Mounts..... pg# 169
	<b>GC-UNV Model</b> Universal Game Console Security Mount For Screens up to 42". Holds PS3™, XBOX 360™ and Wii™ internally..... pg# 170
AV Component Shelves & Accessory Brackets Game Console Mounts	<b>GC Models</b> Game Console Security Covers Holds PS3™, XBOX 360™ and Wii™ internally ..... pg# 171
	<b>MSA-101/MSA-301 Models</b> Flat Panel Display Speaker Mount for Center, Multi-channel or 3-piece LCR Speakers ..... pg# 172
Speaker Mounts Camera Mounts	<b>PSP2/PSP5 Models</b> Universal Speaker Mount for Speakers Weighing up to 8lb (3kg)..... pg# 173
	<b>SPK811 Model</b> Universal Speaker Mount for Speakers Weighing up to 20lb (9kg)..... pg# 174
	<b>SPK815 Model</b> Universal Speaker Mount for Speakers Weighing up to 75lb (34kg)..... pg# 175
	<b>CMR410 Model</b> Camera Mounts for Small to Medium Security Cameras ..... pg# 176



# AV ACCESSORIES

**peerless-AV™**

 **CALL:** 630-375-5100  
800-865-2112

 **FAX:** 630-820-8537  
800-359-6500

 **E-MAIL:**  
info@peerless-av.com

 **ONLINE:**  
www.peerless-av.com



# High Speed HDMI® Cables with Ethernet Type A Connectors

1. HDMI certified. Supports all HDMI version 1.4 features
2. Foamed PE dielectrics for enhanced performance versus PE or PVC dielectrics
3. PCOFC conductors minimize signal loss and distortion versus oxygen free or just copper conductors
4. Aluminum foil and braided PCOF shielding for protection against EMI and RFI, versus aluminum mylar or foil and OFC
5. Durable PVC outer jacket for enhanced durability

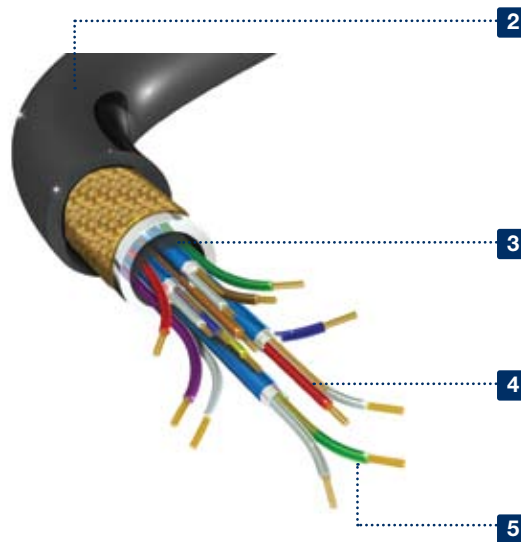

# DELTA SERIES

AV  
ACCESSORIES

## MODELS

<b>DEW-HD05</b>	Black
<b>DEB-HD10</b>	Black
<b>DEB-HD15</b>	Black
<b>DEB-HD20</b>	Black

## SPECIFICATIONS

### Cable Length

<b>DEW-HD05</b>	16' (5m)
<b>DEB-HD10</b>	32' (10m)
<b>DEB-HD15</b>	49' (15m)
<b>DEB-HD20</b>	65' (20m)

### Ship Weight

<b>DEW-HD05</b>	1.2lb (0.5kg)
<b>DEB-HD10</b>	3.1lb (1.4kg)
<b>DEB-HD15</b>	4.2lb (1.9kg)
<b>DEB-HD20</b>	5.3lb (2.4kg)

## CERTIFICATIONS



To verify mount compatibility with any flat panel display or projector model use MountFinder™ at [www.peerless-av.com](http://www.peerless-av.com)



CALL: 630-375-5100  
800-865-2112



FAX: 630-820-8537  
800-359-6500



E-MAIL:  
[info@peerless-av.com](mailto:info@peerless-av.com)



ONLINE:  
[www.peerless-av.com](http://www.peerless-av.com)

### MODELS

<b>SLW-HDRU05</b>	90° Connector	Black
<b>SLW-HDRZ05</b>	270° Connector	Black

### SPECIFICATIONS

<b>Cable Length</b>	16' (5m)
<b>Ship Weight</b>	1.2lb (0.5kg)

### CERTIFICATIONS



1. HDMI certified. Supports all HDMI version 1.4 features
2. Right-angled HDMI connector projects 14mm (0.55") from rear of the displays HDMI socket; compared to 30mm for rotating/swivel type HDMI connectors
3. Ultra slim flat cable 3mm thick; compared to 8mm of typical round HDMI cables of equal performance
4. Right angled, 90°, HDMI connection fits the vast majority of displays with a horizontal HDMI socket (SLW-HDRU05)
5. Right angled, 270°, HDMI connection fits the vast majority of displays with side mounted HDMI sockets (SLW-HDRZ05)



2



To verify mount compatibility with any flat panel display or projector model use MountFinder™ at [www.peerless-av.com](http://www.peerless-av.com)



# High Performance Component Video Cable

3xRCA plugs to 3xRCA plugs

1. Connect Blu-Ray or DVD player and cable or satellite receivers to a flat panel display or projector
2. HD 1080i/720p compatible
3. 24k gold contacts for a superior signal transfer
4. PCOFC oxygen free conductors to minimize signal loss and distortion
5. Braided PCOFC outer shielding and aluminum foil inner shielding for protection against EMI and RFI
6. PVC outer jacket for enhanced durability
7. Foamed PE dielectrics further enhances performance
8. Color coded connectors to easily identify red, green or blue signal conductor

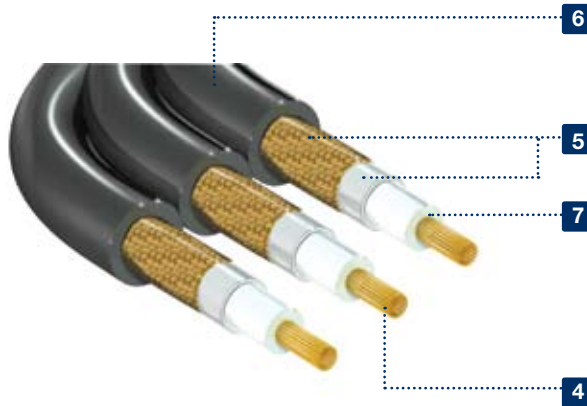

# DELTA

SERIES

AV  
ACCESSORIES

## MODELS

<b>DEB-CV05</b>	Black
<b>DEB-CV10</b>	Black
<b>DEB-CV15</b>	Black
<b>DEB-CV20</b>	Black

## SPECIFICATIONS

### Cable Length

<b>DEB-CV05</b>	16' (5m)
<b>DEB-CV10</b>	32' (10m)
<b>DEB-CV15</b>	49' (15m)
<b>DEB-CV20</b>	65' (20m)

### Ship Weight

<b>DEB-CV05</b>	2.4lb (1kg)
<b>DEB-CV10</b>	4lb (1.8kg)
<b>DEB-CV15</b>	5.1lb (2.3kg)
<b>DEB-CV20</b>	6.6lb (2.9kg)

## CERTIFICATIONS



To verify mount compatibility with any flat panel display or projector model use MountFinder™ at [www.peerless-av.com](http://www.peerless-av.com)



CALL: 630-375-5100  
800-865-2112



FAX: 630-820-8537  
800-359-6500



E-MAIL:  
[info@peerless-av.com](mailto:info@peerless-av.com)



ONLINE:  
[www.peerless-av.com](http://www.peerless-av.com)

# DELTA

SERIES

## Stereo High Performance Audio Cable

2xRCA plugs to 2xRCA plugs

### MODELS

<b>DEW-RR05</b>	Black
<b>DEB-RR10</b>	Black
<b>DEB-RR15</b>	Black
<b>DEB-RR20</b>	Black

### SPECIFICATIONS

#### Cable Length

<b>DEW-RR05</b>	16' (5m)
<b>DEB-RR10</b>	32' (10m)
<b>DEB-RR15</b>	49' (15m)
<b>DEB-HD20</b>	65' (20m)

#### Ship Weight

<b>DEW-RR05</b>	1.2lb (0.5kg)
<b>DEB-RR10</b>	2.8lb (1.2kg)
<b>DEB-RR15</b>	3.8lb (1.7kg)
<b>DEB-RR20</b>	4.7lb (2.1kg)

### CERTIFICATIONS



1. Connect Blu-Ray, DVD or CD players; and cable or satellite receivers to an AV amplifier or Hi-Fi system
2. 24k gold contacts for a superior signal transfer
3. PCOFC oxygen free conductors to minimize signal loss and distortion
4. Braided PCOFC outer shielding and aluminum foil inner shielding for protection against EMI and RFI
5. PVC outer jacket for enhanced durability
6. Foamed PE dielectrics prevent s distortion of high frequency audio signals
7. Color coded connectors to show signal polarity

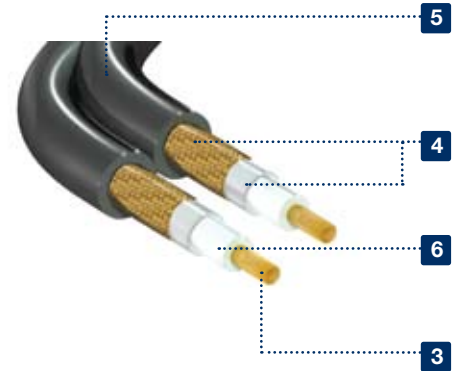

To verify mount compatibility with any flat panel display or projector model use MountFinder™ at [www.peerless-av.com](http://www.peerless-av.com)



CALL: 630-375-5100  
800-865-2112



FAX: 630-820-8537  
800-359-6500



E-MAIL: [info@peerless-av.com](mailto:info@peerless-av.com)



ONLINE: [www.peerless-av.com](http://www.peerless-av.com)

# Portable Stereo Audio Cable

3.5mm jack plug to 2xRCA plugs

1. Connect any device with a headphone port to a home or car audio system
2. 24k gold contacts for a superior signal transfer
3. PCOFC oxygen free conductors to minimize signal loss and distortion
4. PCOFC outer shielding for protection against EMI and RFI
5. PVC outer jacket for enhanced durability
6. Foamed PE dielectrics prevent s distortion of high frequency audio signals
7. Color coded connectors to show signal polarity

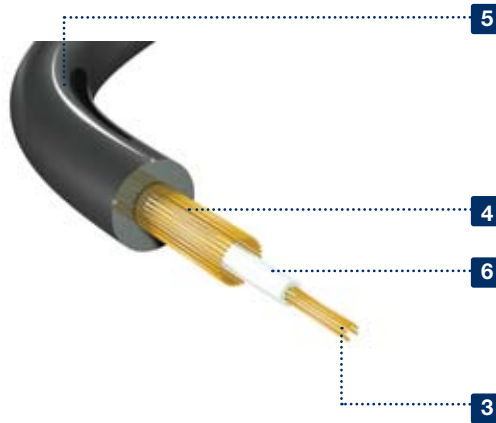

# DELTA

SERIES

AV  
ACCESSORIES

## MODELS

**DEW-JR05** Black

## SPECIFICATIONS

### Cable Length

16' (5m)

### Ship Weight

0.6lb (0.2kg)

## CERTIFICATIONS



To verify mount compatibility with any flat panel display or projector model use MountFinder™ at [www.peerless-av.com](http://www.peerless-av.com)



CALL: 630-375-5100  
800-865-2112



FAX: 630-820-8537  
800-359-6500



E-MAIL:  
[info@peerless-av.com](mailto:info@peerless-av.com)



ONLINE:  
[www.peerless-av.com](http://www.peerless-av.com)

# DELTA

SERIES

## Portable Stereo Audio Cable

3.5mm jack plug to 3.5mm jack plug

### MODELS

**DEW-JJ05** Black

### SPECIFICATIONS

**Cable Length**

16' (5m)

**Ship Weight**

0.6lb (0.2kg)

### CERTIFICATIONS



1. Connects iPods®, MP3 players, or other portable audio devices to AV equipment or car stereo
2. 24k gold contacts for a superior signal transfer
3. PCOFC oxygen free conductors to minimize signal loss and distortion
4. PCOFC outer shielding for protection against EMI and RFI
5. PVC outer jacket for enhanced durability
6. Foamed PE dielectrics prevent s distortion of high frequency audio signals

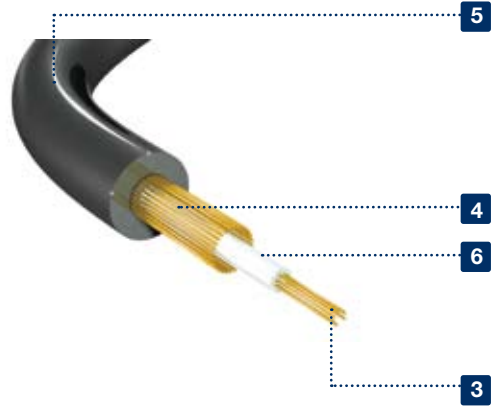

To verify mount compatibility with any flat panel display or projector model use MountFinder™ at [www.peerless-av.com](http://www.peerless-av.com)



CALL: 630-375-5100  
800-865-2112



FAX: 630-820-8537  
800-359-6500



E-MAIL: [info@peerless-av.com](mailto:info@peerless-av.com)



ONLINE: [www.peerless-av.com](http://www.peerless-av.com)

# Cable Management Channel

For Cables

1. Keeps cables out of sight for a clean, professional appearance
2. Paintable plastic to match any environment
3. 5' (1520mm) long with ability to customize to desired length
4. Measures 1.05" (27mm) from wall for low-profile installation
5. 90° corner connector to route cables in any direction
6. 8 wall-attachment clips designed with built-in channels to keep cables in place



## MODELS

Includes Phillips screws and anchors for wall attachment

<b>PCC</b>	White
<b>PCC-B</b>	Black
<b>PCC-S</b>	Silver

## SPECIFICATIONS

### Distance from Wall

1.05" (27mm)

### Product Dimensions (W x H x D)

3.11" x 5.00" x 1.05"  
(79 x 1520 x 27mm)

### Mounting Surfaces

Drywall, wood stud  
and concrete

### Ship Weight

1.6lb (.7kg)

For expanded product information and technical data visit [www.peerless-av.com](http://www.peerless-av.com)

## TECHNICAL DRAWINGS

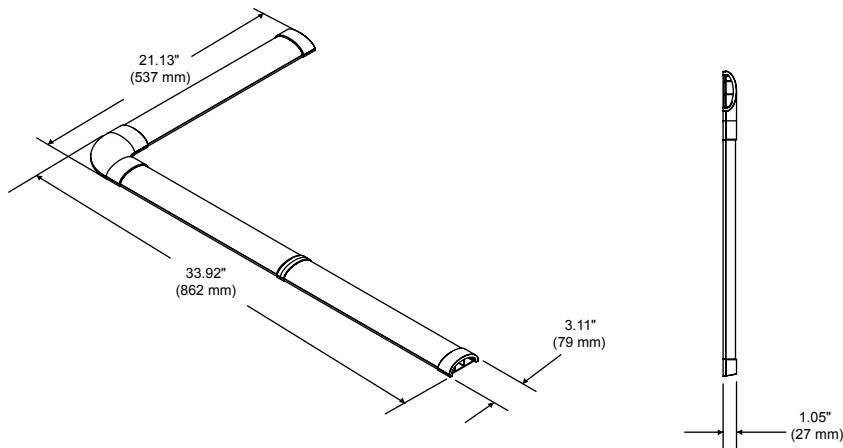

To verify mount compatibility with any flat panel display or projector model use MountFinder™ at [www.peerless-av.com](http://www.peerless-av.com)



CALL: 630-375-5100  
800-865-2112



FAX: 630-820-8537  
800-359-6500



E-MAIL:  
[info@peerless-av.com](mailto:info@peerless-av.com)



ONLINE:  
[www.peerless-av.com](http://www.peerless-av.com)



# 15U AV Component Rack System

Compatible with most standard 19" rack accessories

## MODELS

### Universal Models:

Includes standard hardware (hex or Phillips) for attaching component to mount

**AVM** Black

## SPECIFICATIONS

### Max Load

500lb (227kg)

### Product Dimensions (W x H x D)

25.86" x 32.12" x 24.68"  
(657 x 816 x 627mm)

### Ship Weight

86lb (39kg)

## CERTIFICATIONS

**RoHS**  
compliant

## ACCESSORIES



**AV-SHL:**  
5U Large Shelf



**AV-SHM:**  
2U Medium Shelf



**AV-VSP1:**  
2U Vented Seal Panel

1. Designed for managing components and providing an organized professional look to any AV installation
2. Fully assembled reduces installation time
3. Three sturdy 2U shelves to accommodate most components
4. Rubber wheels for easy movement from location to location
5. Integrated cable management clips assist with routing multiple bundles of cables
6. Open air vented panels, top and sides keep components cool
7. Removable handles provide ease of movement



4



5

1

## TECHNICAL DRAWINGS

For expanded product information and technical data visit [www.peerless-av.com](http://www.peerless-av.com)

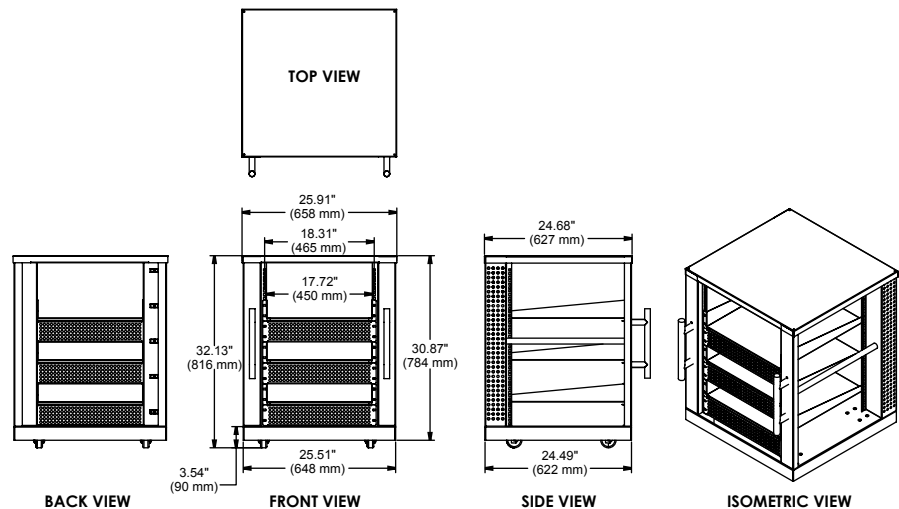

To verify mount compatibility with any flat panel display or projector model use MountFinder™ at [www.peerless-av.com](http://www.peerless-av.com)



CALL: 630-375-5100  
800-865-2112



FAX: 630-820-8537  
800-359-6500



E-MAIL: [info@peerless-av.com](mailto:info@peerless-av.com)



ONLINE: [www.peerless-av.com](http://www.peerless-av.com)



# 30U AV Component Rack System

Compatible with most standard 19" rack accessories



1. Designed for managing components and providing an organized professional look to any AV installation
2. Fully assembled reduces installation time
3. Includes four 2U shelves, one 5U shelf to accommodate most components
4. Rubber wheels for easy movement from location to location
5. Integrated cable management clips assist with routing multiple bundles of cables
6. Open air vented panels, top and sides keep components cool
7. Removable handles provide ease of movement



4

5

1

## MODELS

### Universal Models:

Includes standard hardware (hex or Phillips) for attaching component to mount

**AVL** Black

## SPECIFICATIONS



### Max Load

1,000lb (453kg)

### Product Dimensions (W x H x D)

25.86" x 58.46" x 24.68"  
(657 x 1485 x 627mm)

### Ship Weight

114.6lb (52kg)

## CERTIFICATIONS

**RoHS**  
2002/95/EC

## ACCESSORIES



**AV-SHL:**  
5U Large Shelf



**AV-SHM:**  
2U Medium Shelf



**AV-VSP1:**  
2U Vented Seal Panel

For expanded product information and technical data visit [www.peerless-av.com](http://www.peerless-av.com)

## TECHNICAL DRAWINGS

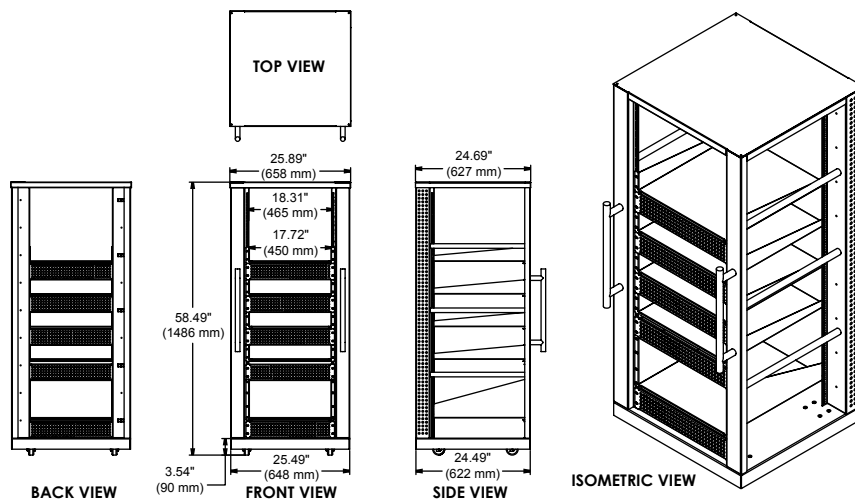

To verify mount compatibility with any flat panel display or projector model use MountFinder™ at [www.peerless-av.com](http://www.peerless-av.com)



**CALL:** 630-375-5100  
800-865-2112



**FAX:** 630-820-8537  
800-359-6500



**E-MAIL:**  
[info@peerless-av.com](mailto:info@peerless-av.com)



**ONLINE:**  
[www.peerless-av.com](http://www.peerless-av.com)



# Video Conference Shelf

## For Video Conference Equipment

### MODELS

#### Universal Models:

Includes standard hardware (hex or Phillips) for attaching component to mount

**ACC309** Black

### SPECIFICATIONS



#### Max Load

25lb (11kg)

#### Product Dimensions (W x H x D)

24.65" x 7.825" x 8.50"  
(626 x 198 x 216mm)

#### Mounting Surfaces

Wood stud

#### Ship Weight

6lb (2.7kg)

### CERTIFICATIONS



1. Mounts to 16" to 24" (406-609mm) wood studs
2. Shelf can be installed above or below flat panel display
3. 4" (101mm) of adjustable height to achieve ideal location of video conferencing equipment
4. Includes hardware for wood stud mounting

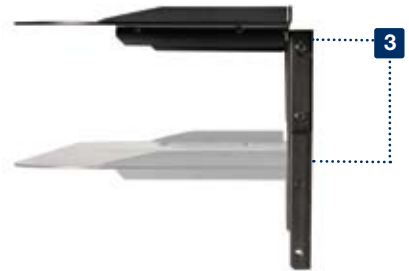

### TECHNICAL DRAWINGS

For expanded product information and technical data visit [www.peerless-av.com](http://www.peerless-av.com)

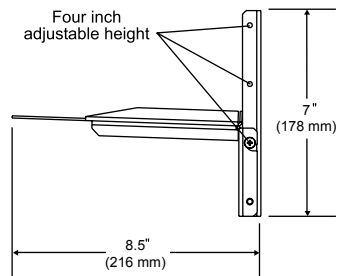
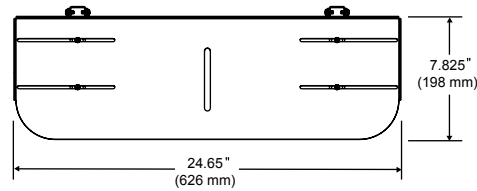

To verify mount compatibility with any flat panel display or projector model use MountFinder™ at [www.peerless-av.com](http://www.peerless-av.com)



CALL: 630-375-5100  
800-865-2112



FAX: 630-820-8537  
800-359-6500



E-MAIL: [info@peerless-av.com](mailto:info@peerless-av.com)



ONLINE: [www.peerless-av.com](http://www.peerless-av.com)

# Adjustable Shelf

For AV Components

1. Versatile design ideal for stacking multiple AV components
2. Adjustable width up to 18.44" (468mm) and depth range of 14.86" to 23" (377-584mm)
3. Snap-on cover hides wall plate and mounting hardware
4. Adjustment knobs allow for easy leveling of components
5. Embossed arms with screw holes secure components to shelf
6. 100lb (45kg) load capacity allows stacking of multiple components, ideal for AV closets

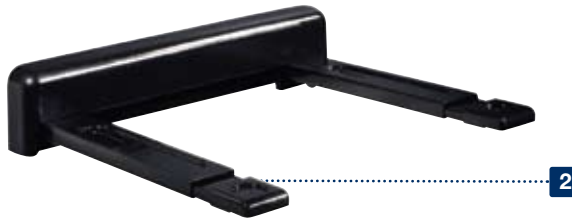

For expanded product information and technical data visit [www.peerless-av.com](http://www.peerless-av.com)

## TECHNICAL DRAWINGS

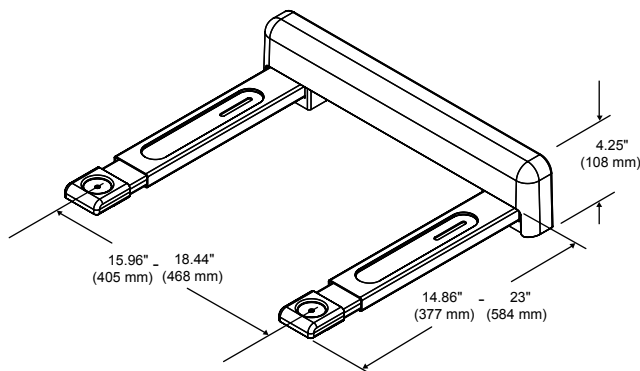

To verify mount compatibility with any flat panel display or projector model use MountFinder™ at [www.peerless-av.com](http://www.peerless-av.com)



CALL: 630-375-5100  
800-865-2112



FAX: 630-820-8537  
800-359-6500



E-MAIL: [info@peerless-av.com](mailto:info@peerless-av.com)



ONLINE: [www.peerless-av.com](http://www.peerless-av.com)



## MODELS

**PS200**

Black

## SPECIFICATIONS



### Max Load

100lb (45kg)

### Product Dimensions (W x H x D)

15.96"-18.44" x 4.25"  
x 14.86"- 23.00"  
(405-468 x 108 x 377-584mm)

### Mounting Surfaces

Wood stud, concrete, cinder  
block and metal stud  
(Metal stud accessory required)

### Ship Weight

10.7lb (4.8kg)

## CERTIFICATIONS



## ACCESSORIES



**ACC215:**  
2-pack Metal Stud  
Fastener Kit .....pg# 196



**IBA4-W:**  
Easy Mount Recessed  
Low Voltage Cable Plate ..... pg# 197



# Adjustable AV Component Shelves

For Most AV Components

## MODELS

**VPM and DS models** Black & Silver (see chart)

## SPECIFICATIONS



**Max Load**

50lb (22kg)\*

**Product Dimensions (W x H x D)**

See chart

**Ship Weight**

See chart

\* When stacking units, do not exceed the load capacity of the display mount and the maximum load capacity of 50lb (22kg) (combined weight of AV Component Shelves and AV components).

\*\* All Jumbo 2000® Mounts with the exception of JM2630, JM2640, JMW2630, JMW2640, JMC2630, JMC640, JMS2630, and JMS2640 which require VPM40-L

\*\*\* Classic, Designer, Small Tray-style, Multi-Display Mounts

## CERTIFICATIONS



## ACCESSORIES



**ACC931/ ACC932/ ACC951:**  
AV Component Shelf Accessory Brackets for Articulating, Pivot and Ceiling Mounts .....pg# 169



**IBA4-W:**  
Easy Mount Recessed Low Voltage Cable Plate ..... pg# 197

1. Adjustable height and width
2. Units can be stacked without additional accessories
3. Accommodates most front loading AV components
4. Security versions available

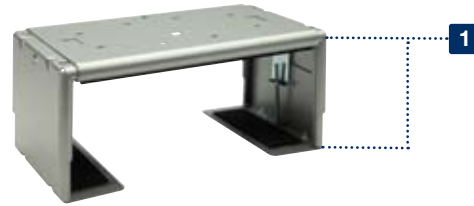

MODEL	Compatibility	Color	Security	Width Range	Height Range	Ship Weight
<b>Jumbo 2000® Series</b>						
VPM25-J	Jumbo 2000 Mounts**	Black	No	13.25"-17.25" (337-438mm)	1.50"-2.75" (38-70mm)	4.7lb (2.1kg)
VPM35-J	Jumbo 2000 Mounts**	Black	No	10.25"-14.25" (260-362mm)	2.69"-4.50" (68-114mm)	6lb (2.7kg)
VPM40-J	Jumbo 2000 Mounts**	Black	No	13.25"-17.25" (337-438mm)	2.69"-4.50" (68-114mm)	6lb (2.7kg)
VPM40-JS	Jumbo 2000 Mounts**	Silver	No	13.25"-17.25" (337-438mm)	2.69"-4.50" (68-114mm)	6lb (2.7kg)
VPM45-J	Jumbo 2000 Mounts**	Black	No	13.25"-17.25" (337-438mm)	4.25"-5.75" (108-146mm)	7lb (3.2kg)
<b>Tray-style for 19"-20" Displays</b>						
VPM25-W	LWB 354/530(T)	Black	No	13.25"-17.25" (337-438mm)	1.50"-2.75" (38-70mm)	4.4lb (2kg)
VPM40-W	LWB 354/530(T)	Black	No	13.25"-17.25" (337-438mm)	2.69"-4.50" (68-114mm)	6lb (2.7kg)
<b>Tray-style for 25"-27" Displays</b>						
VPM35-S	LWB 375/375T	Black	No	10.25"-14.25" (260-362mm)	2.69"-4.50" (68-114mm)	5.6lb (2.5kg)
VPM40-S	LWB 375/375T	Black	No	13.25"-17.25" (337-438mm)	2.69"-4.50" (68-114mm)	5.6lb (2.5kg)
VPM45-S	LWB 375/375T	Black	No	13.25"-17.25" (337-438mm)	4.25"-5.75" (108-146mm)	6.6lb (3kg)
<b>Classic Series™, Designer Series™, Small Tray-style and Multi-Display</b>						
DS25	Other Mounts***	Black	No	13.25"-17.25" (337-438mm)	1.50"-2.75" (38-70mm)	4lb (1.8kg)
DS35	Other Mounts***	Black	No	10.25"-14.25" (260-362mm)	2.69"-4.50" (68-114mm)	5lb (2.3kg)
DS40	Other Mounts***	Black	No	13.25"-17.25" (337-438mm)	2.69"-4.50" (68-114mm)	6lb (2.7kg)
DS45	Other Mounts***	Black	No	13.25"-17.25" (337-438mm)	4.25"-5.75" (108-146mm)	7lb (3.2kg)

To verify mount compatibility with any flat panel display or projector model use MountFinder™ at [www.peerless-av.com](http://www.peerless-av.com)



CALL: 630-375-5100  
800-865-2112



FAX: 630-820-8537  
800-359-6500



E-MAIL:  
[info@peerless-av.com](mailto:info@peerless-av.com)



ONLINE:  
[www.peerless-av.com](http://www.peerless-av.com)

# AV Component Shelf Accessory Brackets

For Articulating, Pivot and Ceiling Mounts

1. Connects Peerless-AV articulating, pivot and ceiling mounts to AV Component Shelves
2. Screw attachment location provides theft-deterrence when AV component is installed
3. Can be installed without removing mount from wall
4. Height adjustability allows AV component to sit flush with display



For expanded product information and technical data visit [www.peerless-av.com](http://www.peerless-av.com)

## TECHNICAL DRAWINGS

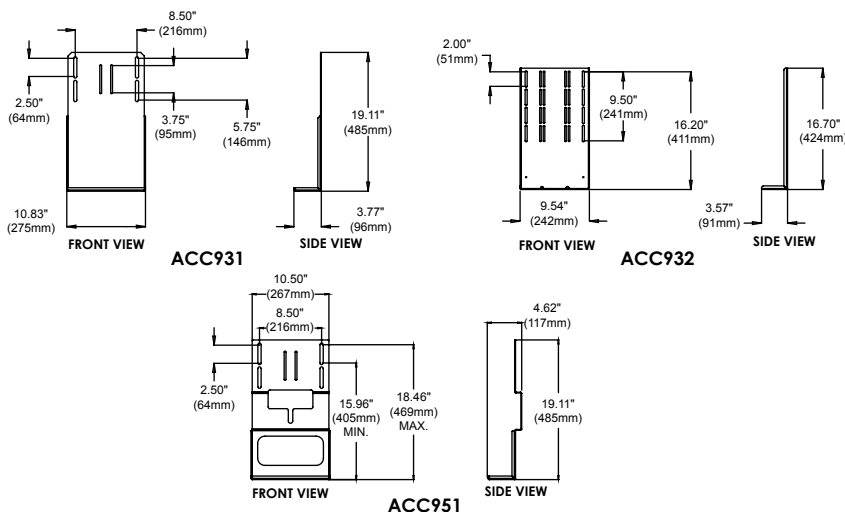

## MODELS

### Universal Models:

Includes standard hardware (hex or Phillips) for attaching component to mount

<b>ACC931</b>	Black
<b>ACC931-S</b>	Silver
<b>ACC932</b>	Black
<b>ACC932-S</b>	Silver
<b>ACC951</b>	Gloss Black

## DVD/VCR CONNECTOR INTERFACE

- ACC931:** Connects AV Component Shelves and pivot/articulating/ceiling mounts with PLP model adapter plates.
- ACC932:** Connects AV Component Shelves and pivot/articulating/ceiling mounts with VESA® 75, 100, 200 x 100 and 200 x 200mm mounting holes.
- ACC951:** Connects AV Component Shelves and SA752PU, SA761PU, SA763PU & SA771PU mounts together.

## SPECIFICATIONS



### Max Load

30lb (13kg)

### Product Dimensions (W x H x D)

<b>ACC931:</b>	10.83" x 19.11" x 3.57" (275 x 485 x 91mm)
<b>ACC932:</b>	9.54" x 16.70" x 3.57" (242 x 424 x 91mm)
<b>ACC951:</b>	10.50" x 19.11" x 4.62" (267 x 485 x 117mm)

### Mounting Surfaces

Peerless-AV articulating wall arms and AV component mounts (Requires Peerless-AV VPM or DS model AV Component shelves)

### Ship Weight

<b>ACC931:</b>	9lb (4.08kg)
<b>ACC932:</b>	6lb (2.72kg)
<b>ACC951:</b>	7lb (3kg)

## CERTIFICATIONS



## ACCESSORIES



**VPM and DS models:**  
AV Component Shelves .....pg# 168



**IBA4-W:**  
Easy Mount Recessed  
Low Voltage Cable Plate ..... pg# 197

To verify mount compatibility with any flat panel display or projector model use MountFinder™ at [www.peerless-av.com](http://www.peerless-av.com)



**CALL:** 630-375-5100  
800-865-2112



**FAX:** 630-820-8537  
800-359-6500



**E-MAIL:**  
[info@peerless-av.com](mailto:info@peerless-av.com)



**ONLINE:**  
[www.peerless-av.com](http://www.peerless-av.com)





# Universal Game Console Security Mount

For Displays up to 42". Holds PS3™, XBOX 360™ and Wii™ internally



## MODELS

**Universal Models:**  
Includes theft resistant hardware for attaching display to mount  
**GC-UNV** Matte Black

## DISPLAY ADAPTER

**VESA® Pattern**  
**Universal Models:** 100, 200 and 200 x 100mm  
Non-VESA® compliant displays require display-specific PLP adapter to be purchased separately.

## SPECIFICATIONS

	<b>Distance from Wall</b>	4.15" (105mm)
	<b>Tilt</b>	0, 5, 10°
	<b>Max Load</b>	100lb (46kg)
	<b>Product Dimensions (W x H x D)</b>	13.74" x 13.12" x 4.15" (349 x 333 x 105mm)
	<b>Mounting Surfaces</b>	Wood stud, concrete, cinder block and metal stud (Metal stud accessory required)
	<b>Ship Weight</b>	13lb (5.9kg)

## CERTIFICATIONS



1. Universal mount protects the game console from tampering and theft
2. Ventilation on the top, bottom and sides allows access and prevents game console overheating
3. Mounts directly to a single stud, desktop or Peerless-AV compatible mount
4. Display can attach to the front of the mount via VESA® hole patterns of 100, 200, 200 x 100mm and PLP
5. For wall applications, display tilts 0°, 5° and 10°



## TECHNICAL DRAWINGS

For expanded product information and technical data visit [www.peerless-av.com](http://www.peerless-av.com)

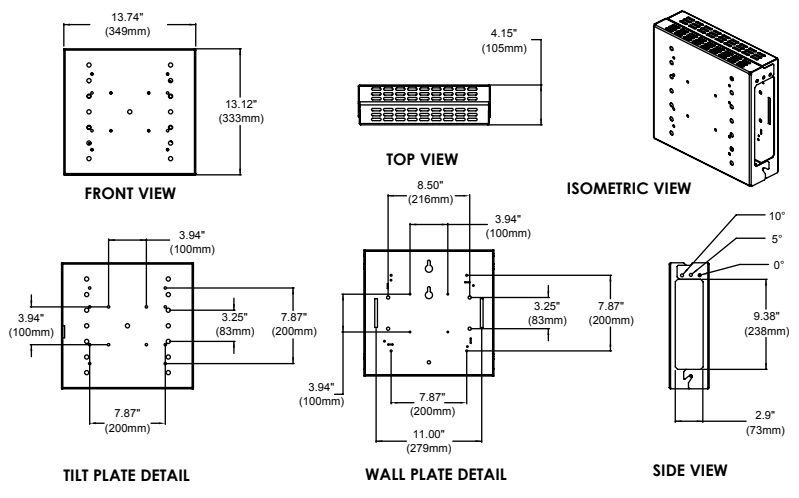

To verify mount compatibility with any flat panel display or projector model use MountFinder™ at [www.peerless-av.com](http://www.peerless-av.com)



# Game Console Security Covers

Holds PS3™, XBOX 360™ and Wii™ internally

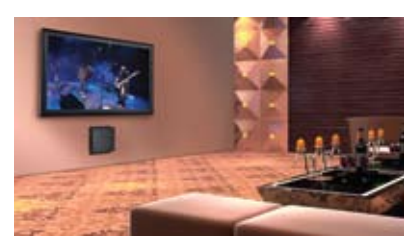

1. Game console security cover prevents theft
2. Open access to console connection points, buttons and disc slot or tray
3. Cover allows for ventilation to prevent overheating
4. Gloss color finish to match game console
5. Easily mounted to a desktop or wall



PC-PS3S



GC-WII



GC-X360

## MODELS

### Dedicated Models:

Includes theft resistant hardware for attaching display to mount

<b>GC-X360</b>	Holds XBOX 360	Black
<b>GC-X360W</b>	Holds XBOX 360	White
<b>GC-WII</b>	Holds Wii	White
<b>GC-PS3S</b>	Holds PS3	Black

## SPECIFICATIONS



### Max Load

25lb (11.3kg)

### Product Dimensions (W x H x D)

<b>GC-X360(W):</b>	10.65" x 3.40" x 14.15" (270 x 86 x 359mm)
<b>GC-WII:</b>	8.68" x 1.91" x 8.00" (220 x 48 x 203mm)
<b>GC-PS3S:</b>	11.65" x 2.90" x 13.15" (295 x 74 x 334mm)

### Mounting Surfaces

Desktop, wall and under cabinet

### Ship Weight

<b>GC-X360(W):</b>	7.1lb (3.2kg)
<b>GC-WII:</b>	2.0lb (0.9kg)
<b>GC-PS3S:</b>	6.8lb (3.1kg)

## CERTIFICATIONS



For expanded product information and technical data visit [www.peerless-av.com](http://www.peerless-av.com)

## TECHNICAL DRAWINGS

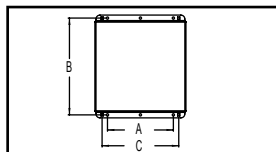

MODEL NO.	DIMENSION "A"	DIMENSION "B"	DIMENSION "C"
GC-PS3S	8.30" (216mm)	12.40" (315mm)	9.85" (250mm)
GC-WII	8.00" (192mm)	7.25" (184mm)	7.35" (187mm)
GC-X360	7.50" (191mm)	13.40" (340mm)	8.85" (225mm)
GC-X360-W	7.50" (191mm)	13.40" (340mm)	8.85" (225mm)

GC-X360 GC-X360-W GC-PS3S GC-WII

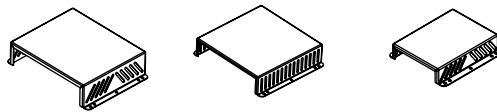

ISOMETRIC VIEW

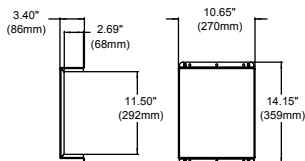

GC-X360 GC-X360-W

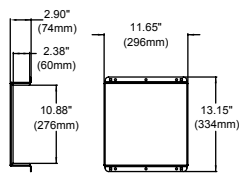

GC-PS3S

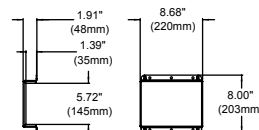

GC-WII

To verify mount compatibility with any flat panel display or projector model use MountFinder™ at [www.peerless-av.com](http://www.peerless-av.com)



CALL: 630-375-5100  
800-865-2112



FAX: 630-820-8537  
800-359-6500



E-MAIL:  
[info@peerless-av.com](mailto:info@peerless-av.com)



ONLINE:  
[www.peerless-av.com](http://www.peerless-av.com)



# Flat Panel Display Speaker Mount

For Center, Multi-channel or 3-piece LCR Speakers

## MODELS

### Dedicated Models:

Includes theft resistant hardware for attaching component to mount

<b>MSA-101</b>	Black
<b>MSA-101S</b>	Silver
<b>MSA-301</b>	Black
<b>MSA-301S</b>	Silver

## SPEAKER ADAPTER

<b>MSA-101:</b>	Accommodates Boston Acoustics model P400 and Polk Audio center channel speakers. <i>Contact Customer Care for compatibility with other models.</i>
<b>MSA-301:</b>	Technologies FS3200LR side and FS3200C center channel speakers and Polk Audio.

## SPECIFICATIONS



### Max Load

<b>MSA-101:</b>	25lb (11kg)
<b>MSA-301:</b>	50lb (22kg)

### Product Dimensions (W x H x D)

<b>MSA-101:</b>	20.00" x 21.20" x 1.18" (508 x 539 x 29mm)
<b>MSA-301:</b>	49"-64" x 27"-32" x 0.93" (1234-1618 x 697-801 x 23mm)

### Ship Weight

<b>MSA-101:</b>	12.5lb (5.7kg)
<b>MSA-301:</b>	23.5lb (10.6kg)

## CERTIFICATIONS



- 10.6" (269mm) adjustable height to align speaker with bottom of display
- MSA-101: Side-to-side adjustability for perfect positioning allows speaker to move with display
- MSA-301: Side-to-side and vertical adjustability for positioning three speakers
- Mounts to Peerless-AV pivot, articulating, ceiling and floor mounts
- Determine that combined weight of speaker(s), display and MSA do not exceed rated load capacity of mount

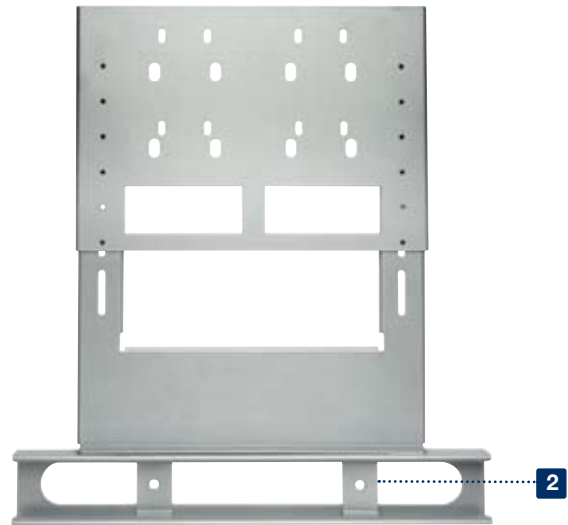

MSA-101



MSA-301

## TECHNICAL DRAWINGS

For expanded product information and technical data visit [www.peerless-av.com](http://www.peerless-av.com)

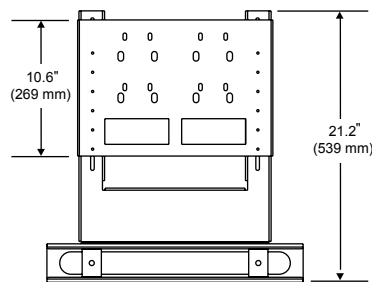

MSA-101

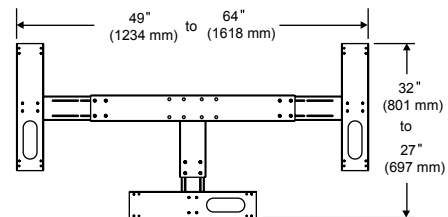

MSA-301

To verify mount compatibility with any flat panel display or projector model use MountFinder™ at [www.peerless-av.com](http://www.peerless-av.com)



CALL: 630-375-5100  
800-865-2112



FAX: 630-820-8537  
800-359-6500



E-MAIL: [info@peerless-av.com](mailto:info@peerless-av.com)



ONLINE: [www.peerless-av.com](http://www.peerless-av.com)

# Universal Speaker Mount

For Speakers Weighing up to 8lb (3kg)

1. Mounts to wall or ceiling
2. Universal design fits most brands
3. Easy tilt, pivot and rotation adjustments
4. 2.15" (54mm) ceiling extension included
5. 1, 2 and 4 hole mounting adapters accommodate speakers with key hole and threaded inserts
6. Includes installation and speaker attachment hardware



## MODELS

### Universal Models:

Includes standard hardware (hex or Phillips) for attaching speaker mount to wall

<b>PSP2</b>	Black	(2 pack)
<b>PSP2-W</b>	White	(2 pack)
<b>PSP5</b>	Black	(5 pack)
<b>PSP5-W</b>	White	(5 pack)

## SPECIFICATIONS



### Tilt | Swivel | Roll

±90° | 360° | 360°

### Max Load

8lb (3kg)

### Product Dimensions (W x H x D)

3.365" x 3.25"-5.40" x 1.75"  
(85 x 83-137 x 44mm)

### Mounting Surfaces

Wood joist and concrete

### Ship Weight

<b>PSP2(-W):</b>	1lb (.5kg)
<b>PSP5(-W):</b>	3lb (1.4kg)

For expanded product information and technical data visit [www.peerless-av.com](http://www.peerless-av.com)

## TECHNICAL DRAWINGS

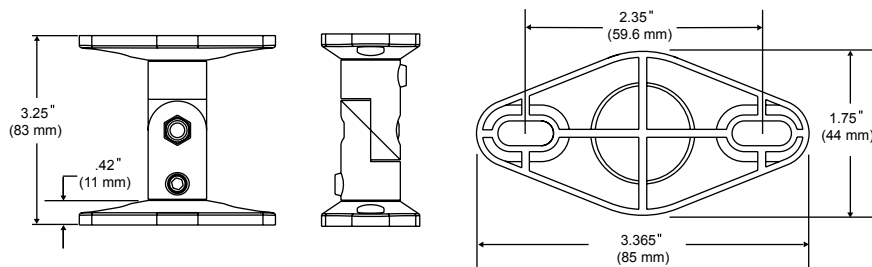

To verify mount compatibility with any flat panel display or projector model use MountFinder™ at [www.peerless-av.com](http://www.peerless-av.com)



**CALL:** 630-375-5100  
800-865-2112



**FAX:** 630-820-8537  
800-359-6500



**E-MAIL:**  
[info@peerless-av.com](mailto:info@peerless-av.com)



**ONLINE:**  
[www.peerless-av.com](http://www.peerless-av.com)



# Universal Speaker Mount

For Speakers Weighing up to 20lb (9kg)

## MODELS

### Universal Models:

<b>SPK811</b>	Black
<b>SPK811W</b>	White

## SPECIFICATIONS

### Tilt | Swivel | Roll

±37.5° | 360° | ±37.5°

### Max Load

20lb (9kg)

### Product Dimensions (W x H x D)

2.02" x 3.27" x 2.43"-4.72"  
(51 x 83 x 43-101mm)

### Mounting Surfaces

Wood stud, metal stud,  
concrete and drywall

### Ship Weight

0.9lb (0.4kg)

## CERTIFICATIONS



1. Ball and socket design provides 37.5° of rotation up or down
2. Concealed mounting screws
3. Flush mounted or used with 3" (76mm) extensions
4. Includes hardware for mounting most commercially available speakers
5. Include fasteners for wood studs, metal studs, concrete and drywall
6. Speaker attachment hardware included
7. Internal speaker wire management



## TECHNICAL DRAWINGS

For expanded product information and technical data visit [www.peerless-av.com](http://www.peerless-av.com)

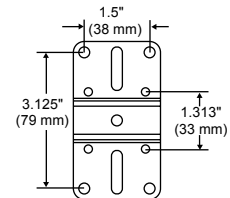
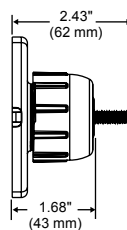
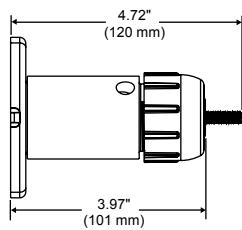

To verify mount compatibility with any flat panel display or projector model use MountFinder™ at [www.peerless-av.com](http://www.peerless-av.com)



CALL: 630-375-5100  
800-865-2112



FAX: 630-820-8537  
800-359-6500



E-MAIL: [info@peerless-av.com](mailto:info@peerless-av.com)



ONLINE: [www.peerless-av.com](http://www.peerless-av.com)

# Universal Speaker Mount

For Speakers Weighing up to 75lb (34kg)

1. Mounting plates have 4" x 4" (101 x 101mm) cut-out for speaker wire access
2. Up to  $\pm 45^\circ$  pivot in vertical and horizontal directions
3. Heavy gauge cold rolled steel construction
4. Requires wall and speaker installation hardware

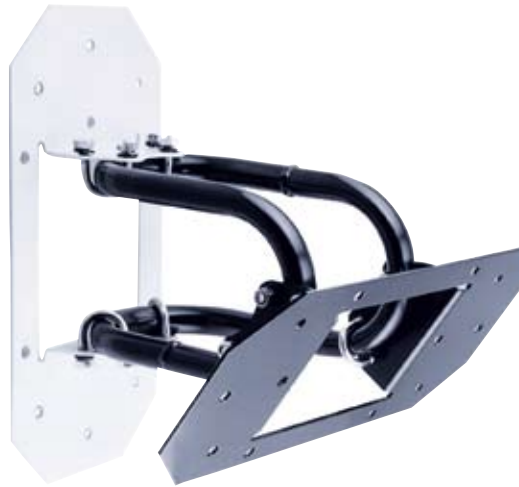

## MODELS

Universal Models:

**SPK815** Black

## SPECIFICATIONS

Tilt | Swivel

$\pm 45^\circ$  |  $\pm 45^\circ$



Max Load

75lb (34kg)

Product Dimensions (W x H x D)

6.00" x 12.00" x 9.125"  
(153 x 305 x 232mm)

Mounting Surfaces

Concrete  
(Concrete accessory required)

Ship Weight

5lb (2.2kg)

## ACCESSORIES



**ACC233/234, ACC243/244:**  
Concrete Anchors ..... pg# 196

## CERTIFICATIONS



For expanded product information and technical data visit [www.peerless-av.com](http://www.peerless-av.com)

## TECHNICAL DRAWINGS

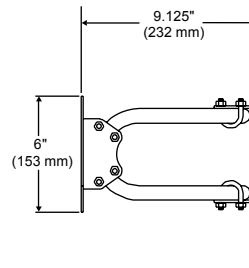
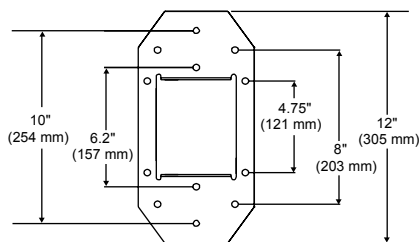

To verify mount compatibility with any flat panel display or projector model use MountFinder™ at [www.peerless-av.com](http://www.peerless-av.com)



CALL: 630-375-5100  
800-865-2112



FAX: 630-820-8537  
800-359-6500



E-MAIL:  
[info@peerless-av.com](mailto:info@peerless-av.com)



ONLINE:  
[www.peerless-av.com](http://www.peerless-av.com)



# Camera Mounts

For Small to Medium Security Cameras

## MODELS

**CMR410** Light Gray  
7" (178mm) Camera Mount

## SPECIFICATIONS

**Tilt | Swivel**

90° | 360°

**Max Load**

10lb (4kg)

**Product Dimensions (W x H x D)**

3.00" x 4.75" x 7.00"  
(76 x 121 x 178mm)

**Mounting Surfaces**

Wall or ceiling

**Ship Weight**

1 lb (0.5kg)

## CERTIFICATIONS



1. Patented ball and socket design for 360° swivel and 90° tilt for ideal positioning of camera
2. Engineered plastic eliminates electrical grounding problems
3. Single point adjustment knob
4. Cable management routing duct
5. Wall or ceiling mountable with option to mount directly to standard electrical outlet box
6. Mounting stud for camera installation



Patented

## TECHNICAL DRAWINGS

For expanded product information and technical data visit [www.peerless-av.com](http://www.peerless-av.com)

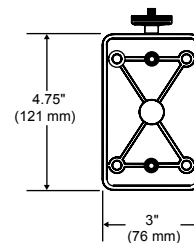
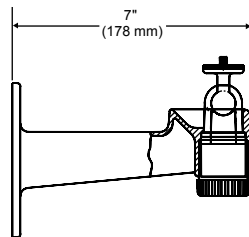

To verify mount compatibility with any flat panel display or projector model use MountFinder™ at [www.peerless-av.com](http://www.peerless-av.com)



CALL: 630-375-5100  
800-865-2112



FAX: 630-820-8537  
800-359-6500



E-MAIL: [info@peerless-av.com](mailto:info@peerless-av.com)



ONLINE: [www.peerless-av.com](http://www.peerless-av.com)



Video Wall Mounts  
 Digital Menu Board Kit  
 Portable Video Wall Cart  
 Dual Display Ceiling Mounts

**DS-VW650**  
 Ultra Thin Flat Video Wall Mount for Flat Panel Displays from 40" up to 75lb (34kg) .....pg# 177

**DS-VW660**  
 Flat Video Wall Mount for 40" to 65" Flat Panel Displays .....pg# 178

**DS-VW765-LAND**  
 Full Service Video Wall Mount - Landscape for 40" to 65" Flat Panel Displays.....pg# 179

**DS-VW765-POR**  
 Full Service Video Wall Mount - Portrait for 42" to 65" Flat Panel Displays .....pg# 180

**DS-VL-H/ACC-DSV Models**  
 Digital Menu Board Kit for 20" to 65" Flat Panel Displays.....pg# 181

**DS-VWC560**  
 Portable Video Wall Cart 2x2 or 2x1 Configurations for 40" to 60" Displays.....pg# 182

**DST940/DST965**  
 Dual Display Ceiling Mounts for Flat Panel Displays.....pg# 183

Media Player Storage Mounts

**DST660 Model**  
 Flat/Tilt Wall Mount with Media Device Storage for 40" to 60" Flat Panel Displays.....pg# 184

**DST360 Model**  
 Flat/Tilt Universal Wall or Ceiling Mount  
 with Media Player Storage for 26" to 60" Flat Panel Displays .....pg# 184

**DS415 Model**  
 Wall Mount with Media Player Storage for 32" to 52" Flat Panel Displays .....pg# 184

**DSX750 Model**  
 Media Player Storage for 32" to 60" Flat Panel Displays .....pg# 184

**DS334 Model**  
 Media Player Mounting Bracket .....pg# 184

**DS495 Model**  
 Media Player Mounting Plate for Apple Mac Mini Computer and AC Power Adapter.....pg# 184

**DSX200 Model**  
 Shelf Bracket for Media Devices .....pg# 184

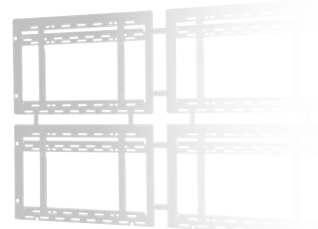

DIGITAL SIGNAGE

**peerless-AV™**

 **CALL:** 630-375-5100  
 800-865-2112

 **FAX:** 630-820-8537  
 800-359-6500

 **E-MAIL:**  
 info@peerless-av.com

 **ONLINE:**  
 www.peerless-av.com



# Ultra Thin Flat Video Wall Mount

For Flat Panel Displays from 40" up to 75lb (34kg)

1. Unique modular design offers unlimited video wall display configurations
2. Display specific wall plate spacers eliminate the guesswork and on-site installation calculations
3. Simple horizontal adjustment makes aligning screens quick and easy
4. Ultra-thin design provides streamlined video wall profiles
5. Durable locking rail holds the display ensuring a safe and secure installation
6. Includes security hardware that helps deter tampering and theft
7. All necessary mounting hardware included
8. Allows ultra thin displays to meet ADA requirement, which states display face must extend no more than 4" (102mm) off the wall

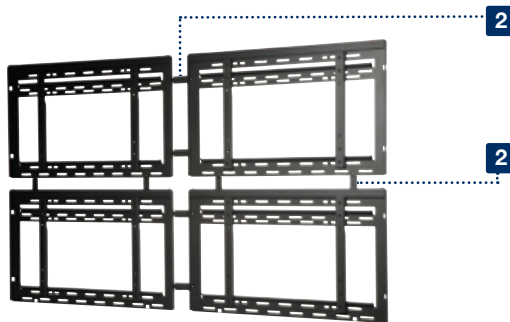
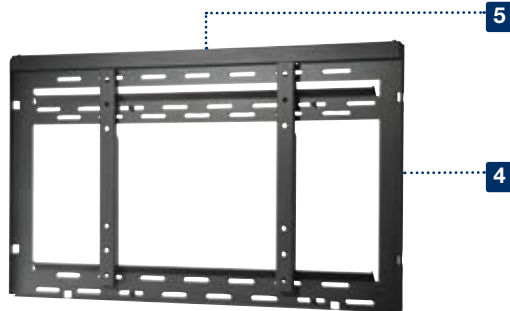

For expanded product information and technical data visit [www.peerless-av.com](http://www.peerless-av.com)

## TECHNICAL DRAWINGS

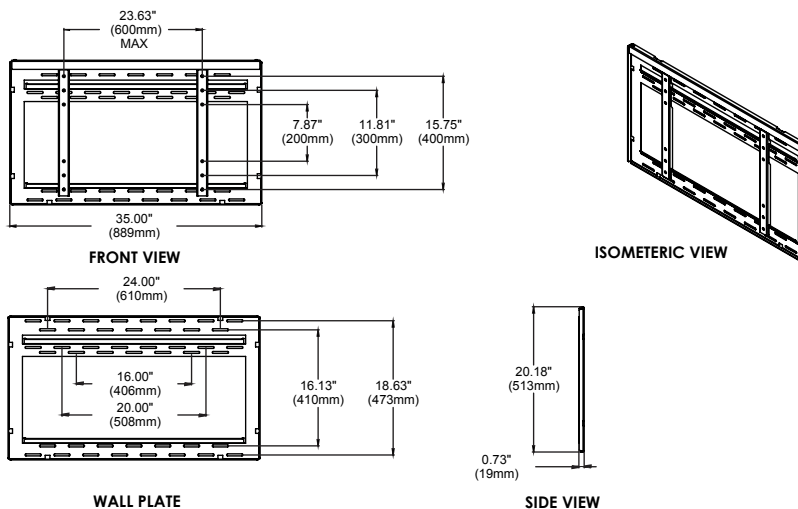

Digital Signage

## MODELS

### Universal Models:

Includes theft resistant hardware for attaching display to mount

**DS-VW650** Black

## DISPLAY ADAPTER



### VESA® Pattern

Universal Models: In 100mm increments, starting at 200 x 200 up to 600 x 400mm

## SPECIFICATIONS



### Distance from Wall

0.73" (19mm)



### Max Load

75lb (34kg)

### Product Dimensions (W x H x D)

35.00" x 20.18" x 0.73"  
(889 x 513 x 19mm)

### Mounting Surfaces

Wood stud, solid concrete, cinder block

### Ship Weight

16lb (7.26kg)

## CERTIFICATIONS



## ACCESSORIES



**DS-VWSxxx:**  
 Wall Plate Alignment Spacers  
 Contact Peerless-AV Customer Care for display-specific models.

To verify mount compatibility with any flat panel display or projector model use MountFinder™ at [www.peerless-av.com](http://www.peerless-av.com)



CALL: 630-375-5100  
800-865-2112



FAX: 630-820-8537  
800-359-6500



E-MAIL: [info@peerless-av.com](mailto:info@peerless-av.com)



ONLINE: [www.peerless-av.com](http://www.peerless-av.com)



# Flat Video Wall Mount

For 40" to 65" Flat Panel Displays

## MODELS

### Universal Models:

Includes theft resistant hardware for attaching display to mount  
**DS-VW660** Black

## DISPLAY ADAPTER

### VESA® Pattern

**Universal Models:** In 100mm increments, starting at 200 x 200 up to 600 x 400mm  
 Non-VESA® compatible displays require PLP adapter plate to be purchased separately.

## SPECIFICATIONS

### Distance from Wall

3.06" (78mm)

### Max Load

200lb (91kg)

### Product Dimensions (W x H x D)

35.00" x 20.10" x 3.06"  
 (889 x 510 x 78mm)

### Mounting Surfaces

Wood stud, concrete, cinder block and metal stud  
 (Metal stud accessory required)

### Ship Weight

43lb (19.5kg)

## CERTIFICATIONS

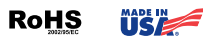

## ACCESSORIES



**ACC415:**  
 4-pack Metal Stud Fastener Kit ..... pg# 196



**DS-VWSxxx:**  
 Wall Plate Alignment Spacers  
 Contact Peerless-AV Customer Care for display-specific models.

**PLP-xxx:**  
 PLP Adapter Plates  
 Contact Peerless-AV Customer Care for more information.

1. Modular mount for unlimited video wall display configurations
2. Display specific wall plate spacers eliminate the guesswork and on-site installation calculations
3. 4 points of tool-less micro adjustments align the displays
4. Displays and mounts sit flush against the wall for a clean profile
5. Integrated cable management tie-backs make cabling simple
6. Adjustable VESA® mounting hole patterns in 100mm increments, starting at 200 x 200mm up to 600 x 400mm. Additional patterns supported with adapter plates.



Patented

## TECHNICAL DRAWINGS

For expanded product information and technical data visit [www.peerless-av.com](http://www.peerless-av.com)

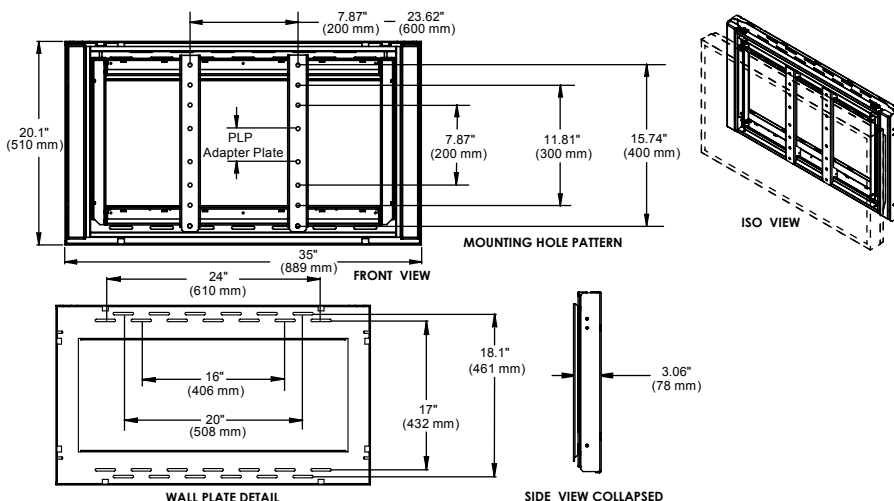

To verify mount compatibility with any flat panel display or projector model use MountFinder™ at [www.peerless-av.com](http://www.peerless-av.com)



CALL: 630-375-5100  
 800-865-2112



FAX: 630-820-8537  
 800-359-6500



E-MAIL: [info@peerless-av.com](mailto:info@peerless-av.com)



ONLINE: [www.peerless-av.com](http://www.peerless-av.com)

# Full Service Video Wall Mount - Landscape

For 40" to 65" Flat Panel Displays

1. Modular mount for unlimited video wall display configurations
2. Display specific wall plate spacers eliminate the guesswork and on-site installation calculations
3. 8 points of tool-less micro adjustments align the displays
4. Displays click securely into place
5. Displays sit flush against the wall for a clean appearance on all sides
6. Pull-out/prop-open mechanism provides quick service access
7. Integrated cable management tie-backs make cabling simple
8. Includes security hardware that helps deter tampering and theft
9. VESA® mounting hole patterns from 200 x 200mm up to 700 x 400mm in 100mm increments. Additional patterns supported with adapter plates.

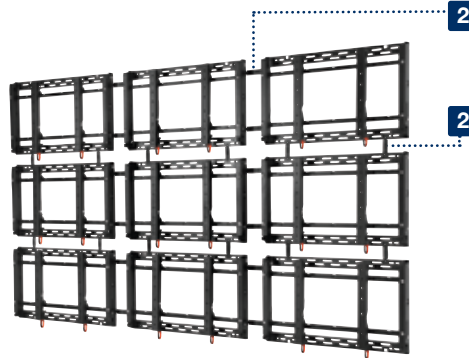
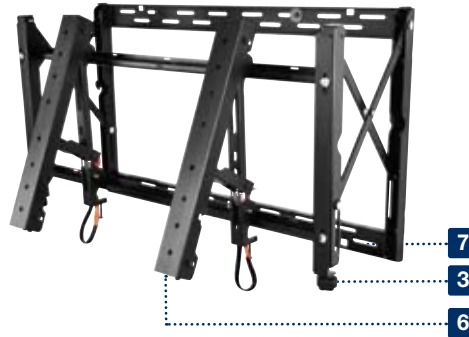

Patented

For expanded product information and technical data visit [www.peerless-av.com](http://www.peerless-av.com)

## TECHNICAL DRAWINGS

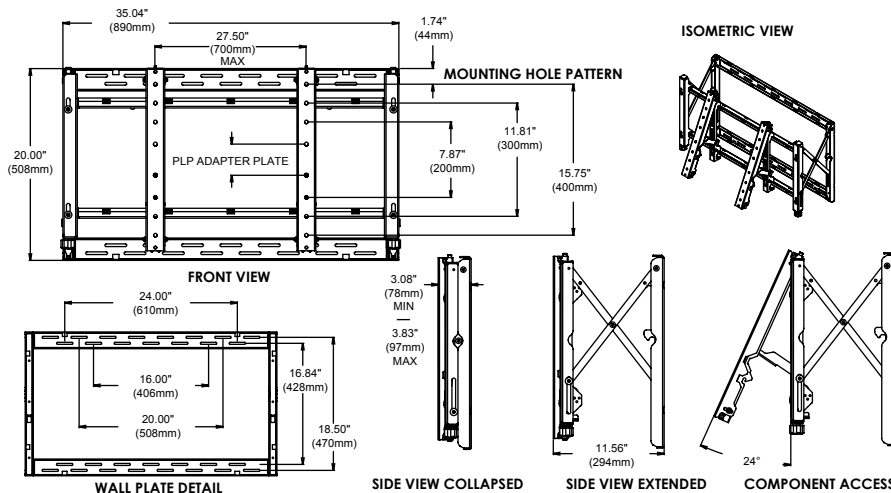

## MODELS

### Universal Models:

Includes theft resistant hardware for attaching display to mount  
**DS-VW765-LAND** Black

## DISPLAY ADAPTER



### VESA® Pattern

**Universal Models:** In 100mm increments, starting at 200 x 200 up to 700 x 400mm  
 Non-VESA® compatible displays require PLP adapter plate to be purchased separately.

## SPECIFICATIONS



### Distance from Wall

3.08"-3.83" (78-97mm)



### Max Load

125lb (56.8kg)

### Product Dimensions (W x H x D)

35.04" x 20.00" x 3.08"-3.83"  
 (890 x 508 x 78-97mm)

### Mounting Surfaces

Wood stud, solid concrete and cinder block

### Ship Weight

43lb (19.57kg)

## CERTIFICATIONS



## ACCESSORIES



**DS-VWSxxx:** Wall Plate Alignment Spacers  
 Contact Peerless-AV Customer Care for display-specific models.



**DS-ACC765:** Cable Release Kit for recessed wall applications  
 Contact Peerless-AV Customer Care for more information.

**PLP-xxx:** PLP Adapter Plates  
 Contact Peerless-AV Customer Care for more information.

Scan QR code with your Smartphone to watch a video about our Full Service Video Wall or visit [videos.peerless-av.com](http://videos.peerless-av.com).



To verify mount compatibility with any flat panel display or projector model use MountFinder™ at [www.peerless-av.com](http://www.peerless-av.com)



CALL: 630-375-5100  
 800-865-2112



FAX: 630-820-8537  
 800-359-6500



E-MAIL: [info@peerless-av.com](mailto:info@peerless-av.com)



ONLINE: [www.peerless-av.com](http://www.peerless-av.com)



# Full Service Video Wall Mount - Portrait

For 42" to 65" Flat Panel Displays

## MODELS

### Universal Models:

Includes theft resistant hardware for attaching display to mount  
**DS-VW765-POR** Black

## DISPLAY ADAPTER

### VESA® Pattern

**Universal Models:** In 100mm increments, starting at 200 x 200 up to 600 x 400mm  
 Non-VESA® compatible displays require PLP adapter plate to be purchased separately.

## SPECIFICATIONS

### Distance from Wall

3.22"-3.97" (81-100mm)

### Max Load

150lb (68kg)

### Product Dimensions (W x H x D)

21.70" x 26.90" x 3.30"-3.97"  
 (551 x 683 x 81-100mm)

### Mounting Surfaces

Wood stud, solid concrete and cinder block

### Ship Weight

40lb (18.2kg)

## CERTIFICATIONS



## ACCESSORIES



**DS-VWSxxx-P:**  
 Wall Plate Alignment Spacers  
 Contact Peerless-AV Customer Care for display-specific models.



**DS-ACC765:**  
 Cable Release Kit for recessed wall applications  
 Contact Peerless-AV Customer Care for more information.

### PLP-xxx:

PLP Adapter Plates  
 Contact Peerless-AV Customer Care for more information.

Scan QR code with your Smartphone to watch a video about our Full Service Video Wall or visit [videos.peerless-av.com](http://videos.peerless-av.com).



1. Modular mount for unlimited video wall display configurations
2. Display specific wall plate spacers eliminate the guesswork and on-site installation calculations
3. 8 points of tool-less micro adjustments align the displays
4. Displays click securely into place against the wall with spring-loaded mechanism
5. Displays and mounts sit flush against the wall for a clean side appearance
6. Pull-out/prop-open mechanism provides quick service access
7. Integrated cable management tie-backs make display to display cabling simple
8. Includes security hardware that helps deter tampering and theft
9. VESA® mounting hole patterns from 200 x 200mm up to 400 x 600mm in 100mm increments. Additional patterns supported with adapter plates.

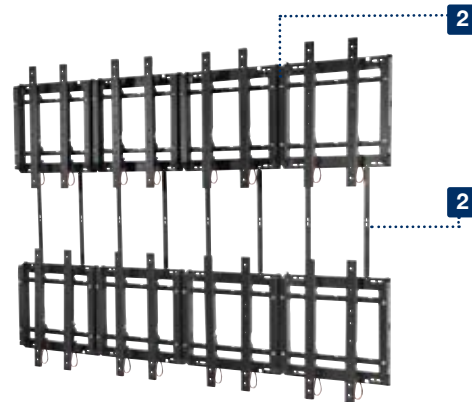
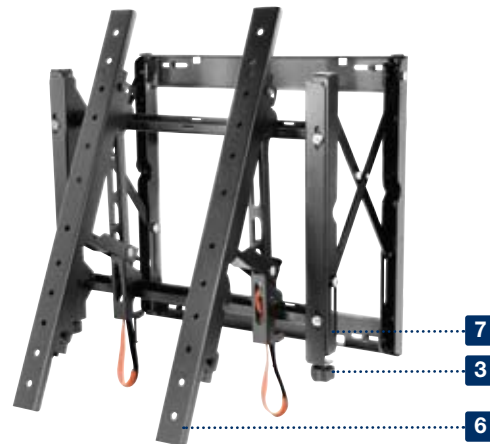

Note: 22" minimum display height

Patented

## TECHNICAL DRAWINGS

For expanded product information and technical data visit [www.peerless-av.com](http://www.peerless-av.com)

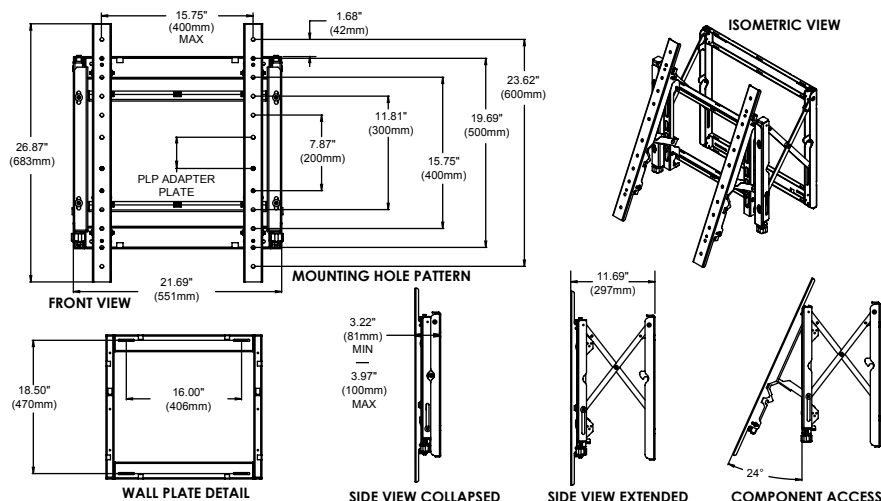

To verify mount compatibility with any flat panel display or projector model use MountFinder™ at [www.peerless-av.com](http://www.peerless-av.com)



# Digital Menu Board Kit

For 20" to 65" Flat Panel Displays



1. Create any combination of wall plates and vertical rails forming a limitless linear array of displays
2. Install multiple displays onto the mounting system with virtually no measuring required
3. Tilt displays to -5°, 0°, 5°, 10° and 15°
4. Horizontal adjustment to create a seamless appearance
5. Portrait or landscape orientation
6. Prevent tampering and theft with included security hardware

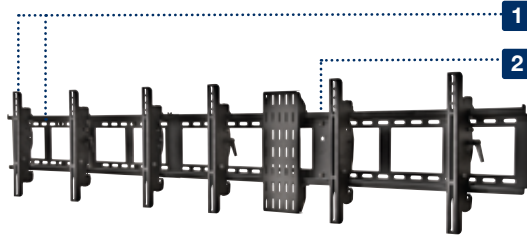

Configuration Shown: DS-VL-H048 and DS-VL-H036 and ACC-DSV329 with accessory DS-ACC-LDCM



Configuration Shown: DS-VL-H060 with ACC-DSV449

### Horizontal Wall Plates

Model	Product Dimensions (W x H x D)	Max Load	Ship Weight
DS-VL-H018	18.00" x 7.50" x 0.70" (457.2 x 190.5 x 17.78mm)	350lb (158.8kg)	4.5lb (2.04kg)
DS-VL-H024	24.00" x 7.50" x 0.70" (609.6 x 190.5 x 17.78mm)	350lb (158.8kg)	5.5lb (2.49kg)
DS-VL-H036	36.00" x 7.50" x 0.70" (914.4 x 190.5 x 17.78mm)	350lb (158.8kg)	6.7lb (3.04kg)
DS-VL-H048	48.00" x 7.50" x 0.70" (1219.20 x 190.5 x 17.78mm)	350lb (158.8kg)	7.9lb (3.58kg)
DS-VL-H060	60.00" x 7.50" x 0.70" (1524 x 190.5 x 17.78mm)	350lb (158.8kg)	9.1lb (4.13kg)
DS-VL-H072	72.00" x 7.50" x 0.70" (1828.8 x 190.5 x 17.78mm)	350lb (158.8kg)	14.01 (6.35kg)

### Vertical rails

Model	Product Dimensions (W x H x D)	Max Load	Ship Weight
ACC-DSV240	1.25" x 10.30" x 2.55" (31.75 x 261.62 x 64.77mm)	125lb (56kg)	5.32lb (2.41kg)
ACC-DSV329	1.25" x 13.50" x 2.49" (31.75 x 342.9 x 63.25mm)	150lb (68kg)	6.07lb (2.75kg)
ACC-DSV449	1.25" x 18.50" x 2.40" (31.75 x 469.9 x 60.96mm)	175lb (79kg)	7.26lb (3.29kg)
ACC-DSV503	1.25" x 20.62" x 2.89" (31.75 x 523.75 x 73.41mm)	250lb (113.4kg)	7.99lb (3.62kg)
ACC-DSV745	1.25" x 30.25" x 2.82" (31.75 x 768.35 x 71.63mm)	350lb (158.8kg)	8.9lb (4.04kg)

### Cable Management Accessory

Model	Product Dimensions (W x H x D)	Ship Weight
DS-ACC-LDCM	5.25" x 12.27" x 1.27" (133 x 312 x 32mm)	2.1lb (.95kg)

Patented

For expanded product information and technical data visit [www.peerless-av.com](http://www.peerless-av.com)

## TECHNICAL DRAWINGS

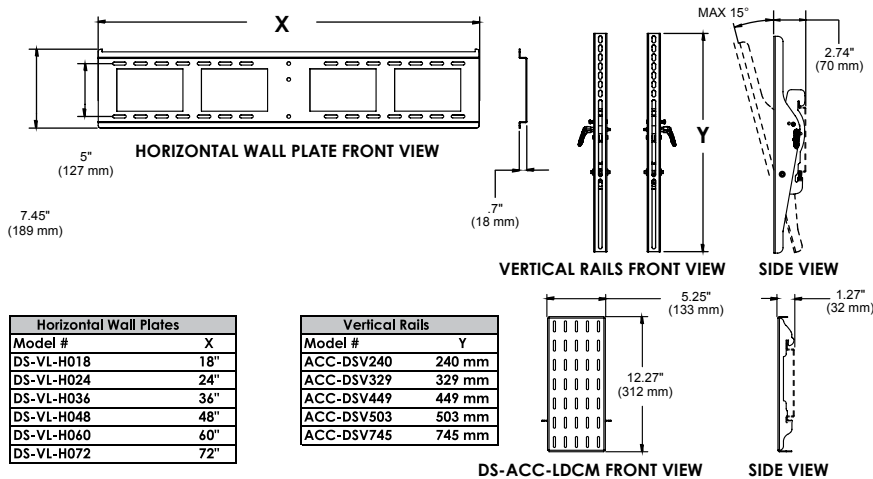

Horizontal Wall Plates	
Model #	X
DS-VL-H018	18"
DS-VL-H024	24"
DS-VL-H036	36"
DS-VL-H048	48"
DS-VL-H060	60"
DS-VL-H072	72"

Vertical Rails	
Model #	Y
ACC-DSV240	240 mm
ACC-DSV329	329 mm
ACC-DSV449	449 mm
ACC-DSV503	503 mm
ACC-DSV745	745 mm

## MODELS

### Universal Models:

Includes theft resistant hardware for attaching display to mount  
**DS-VL-H models** Horizontal Wall Plates Black  
**ACC-DSV models** Vertical rails Black

## DISPLAY ADAPTER



### VESA® Pattern

ACC-DSV240:	up to 240mm
ACC-DSV329:	up to 329mm
ACC-DSV449:	up to 449mm
ACC-DSV503:	up to 503mm
ACC-DSV745:	up to 745mm

## SPECIFICATIONS



### Distance from Wall

2.74" (70mm)



### Tilt

-5°, 0°, 5°, 10°, 15°

### Max Load

See chart

### Product Dimensions (W x H x D)

See chart

### Mounting Surfaces

Wood studs, concrete, cinder block and metal stud (Metal stud accessory required)

### Ship Weight

See chart

## CERTIFICATIONS



## ACCESSORIES



**ACC415:**  
4-pack Metal Stud Fastener Kit ..... pg# 196



**DS-ACC-LDCM:**  
Cable Management Accessory

Scan QR code with your Smartphone to use our Menuboard Configurator or visit [info.peerless-av.com/Menuboard](http://info.peerless-av.com/Menuboard).



To verify mount compatibility with any flat panel display or projector model use MountFinder™ at [www.peerless-av.com](http://www.peerless-av.com)



CALL: 630-375-5100  
800-865-2112



FAX: 630-820-8537  
800-359-6500



E-MAIL:  
[info@peerless-av.com](mailto:info@peerless-av.com)



ONLINE:  
[www.peerless-av.com](http://www.peerless-av.com)



# Portable Video Wall Cart

2x2 or 2x1 Configurations for 40" to 60" Flat Panel Displays

## MODELS

### Universal Models:

Includes theft resistant hardware for attaching display to mount  
**DS-VWC560** Black

## DISPLAY ADAPTER

### VESA® Pattern

**Universal Models:** In 100mm increments, starting at 200 x 200 up to 600 x 400mm  
 Non-VESA® compatible displays require PLP adapter plate to be purchased separately.

## SPECIFICATIONS

### Max Load

500lb (227kg)

### Product Dimensions (W x H x D)

71.54" x 81.16" x 39.22"  
 (1817 x 2061 x 996mm)

### Ship Weight

230lb (105kg)

## CERTIFICATIONS



## ACCESSORIES

**PLP-xxx:**  
 PLP Adapter Plates  
 Contact Peerless-AV Customer Care for more information.

1. Lockable 5" (127mm) casters enable safe and easy maneuverability over various flooring surfaces
2. Displays are height adjustable
3. Tool-less micro adjustment allow for precise alignment
4. Free standing video wall solution for 2x2 or 2x1 display configurations
5. Cable management through the stand upright columns
6. Mounting hole patterns of 200 x 200 up to 600 x 400mm. Additional patterns supported with adapter plates
7. Base cover with internal media player shelf, hides wires for a clean appearance



2x2 configuration

Patented

## TECHNICAL DRAWINGS

For expanded product information and technical data visit [www.peerless-av.com](http://www.peerless-av.com)

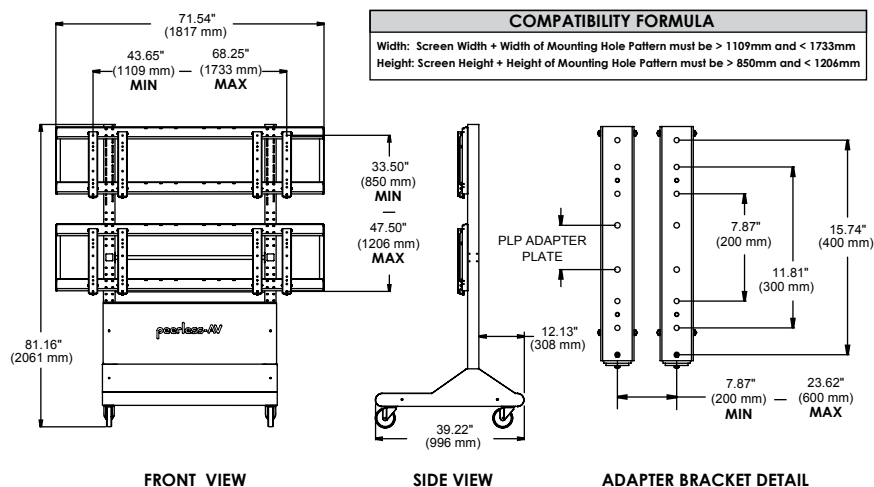

To verify mount compatibility with any flat panel display or projector model use MountFinder™ at [www.peerless-av.com](http://www.peerless-av.com)

# Dual Display Ceiling Mounts

For Flat Panel Displays

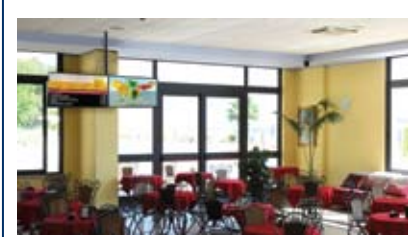

## DST940

1. Single adapter plate keeps the face of the displays on the same plane
2. Easy glide bracket design ensures display is securely attached to the adapter plate
3. Universal display brackets quickly hook onto adapter plate for fast installation
4. Horizontal adjustment allows for easily sliding displays together
5. Displays tilt from 0° to 20° for ideal viewing angle



**DST940**  
Patented

## DST965

1. Holds two displays back to back at a 20° fixed tilt
2. Removable side panels for easy maintenance
3. Two component shelves provide storage for standard size computers
4. Cords are routed through column for a clean appearance
5. Includes Peerless-AV universal mounting brackets

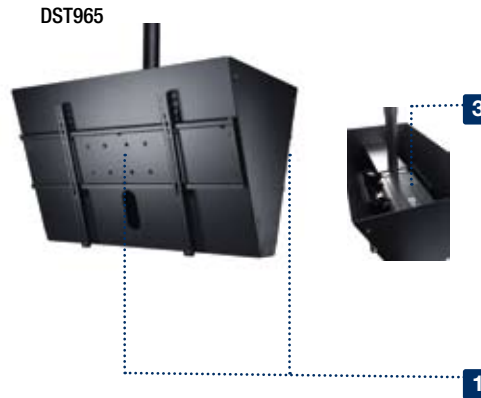

**DST965**

For expanded product information and technical data visit [www.peerless-av.com](http://www.peerless-av.com)

## TECHNICAL DRAWINGS

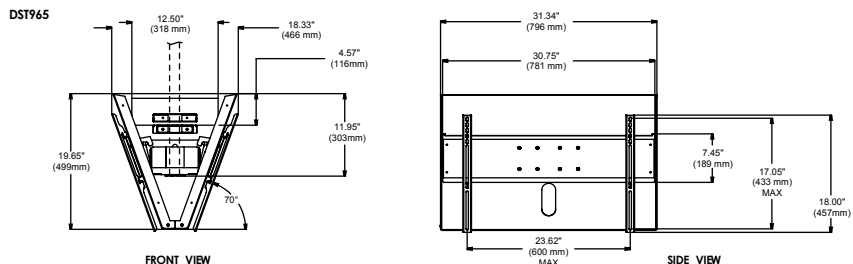
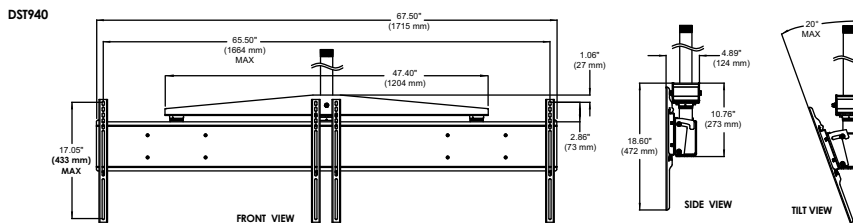

## MODELS

### Universal Models:

Includes theft resistant hardware for attaching display to mount

**DST940** For 37" to 46" Displays Black  
**DST965** For 37" to 50" Displays Black

## DISPLAY ADAPTER



### Mounting Pattern

<b>DST940:</b>	1,664 x 433mm (65.50" W x 17.05" H)
<b>DST965:</b>	729 x 433mm (28.70" W x 17.05" H)

## SPECIFICATIONS



### Tilt

<b>DST940:</b>	0°-20°
<b>DST965:</b>	20° fixed



### Max Load

<b>DST940:</b>	150lb (68kg)
<b>DST965:</b>	300lb (136kg)

### Product Dimensions (W x H x D)

<b>DST940:</b>	67.50" x 18.60" x 4.89" (1714 x 472 x 124mm)
<b>DST965:</b>	37.75" x 19.50" x 18.97" (959 x 495 x 482mm)

### Mounting Surfaces

<b>DST940:</b>	Ceiling Accessory Required
<b>DST965:</b>	Unistrut

### Ship Weight

<b>DST940:</b>	57lb (25.8kg)
<b>DST965:</b>	127lb (57.7kg)

## CERTIFICATIONS



## ACCESSORIES



**ADD Models:**  
Ceiling Extensions .....pg# 194



**AEC, ALU and EXT Models:**  
Ceiling Extensions ..... pg# 193



**ACC, CMJ, DCS, DCT Models:**  
Ceiling Plates ..... pg# 190-192

To verify mount compatibility with any flat panel display or projector model use MountFinder™ at [www.peerless-av.com](http://www.peerless-av.com)



**CALL:** 630-375-5100  
800-865-2112



**FAX:** 630-820-8537  
800-359-6500



**E-MAIL:**  
[info@peerless-av.com](mailto:info@peerless-av.com)



**ONLINE:**  
[www.peerless-av.com](http://www.peerless-av.com)

**DST660** Flat/Tilt Wall Mount with Media Device Storage for 40" to 60" Flat Panel Displays

1. Compatible with VESA® mounting hole patterns from 200 x 100 up to 400 x 400mm
2. Adapter plate compatible for VESA® patterns larger than 400 x 400mm
3. Display can be mounted in portrait or landscape
4. Continuous tilt options from 0° to 7° or fixed tilt at 0°, 3°, 5° and 7°
5. Accommodates media players up to 12.00" x 13.00" x 2.40" (305 x 330 x 61mm)
6. The media player can be removed from the bottom if replacement, repair or maintenance is necessary without having to remove the display
7. Included security hardware deters tampering and theft

**Mounting Surface:** Wood stud, concrete, cinder block and metal stud (metal stud hardware included)

**Max Load:** 125lb (57kg)  
**Color:** Black

**DST360** Flat/Tilt Universal Wall or Ceiling Mount with Media Player Storage for 26" to 60" Flat Panel Displays

1. VESA® 100 x 100, 200 x 100, 200 x 200 and 300 x 300mm compliant
2. Compatible with Peerless-AV PLP adapter plates
3. Accommodates media players up to 15.00" x 9.00" x 3.00" (381 x 229 x 76mm)
4. Mount props open for easy access to the media player without removing the display
5. Ceiling mounted: swivel up to 360° allows for optimum viewing angle; Wall mounted: flat and tilt option up to 20°
6. Universal mounting in either portrait or landscape orientation

**Mounting Surface:** Wood stud, concrete, cinder block and metal stud (metal stud hardware included)

**Max Load:** 150lb (68kg)  
**Ship Weight:** 40.5lb (18.37kg)  
**Color:** Black

**DS415** Wall Mount with Media Player Storage for 32" to 52" Flat Panel Displays

1. VESA® 100 x 100, 200 x 100 and 200 x 200mm compliant
2. Accommodates media players up to 14.10" x 10.81" x 3.60" (358 x 275 x 91mm)
3. Access panels on both sides of the mount provide access to electronic components

**Mounting Surface:** Wood stud, concrete, cinder block and metal stud (metal stud hardware included)

**Max Load:** 150lb (68kg)  
**Ship Weight:** 19lb (8.67kg)  
**Color:** Black

**DSX750** Media Player Storage for 32" to 60" Flat Panel Displays

1. VESA® 100 x 100, 200 x 100 and 200 x 200mm compliant
2. Accommodates media players up to 9.50" x 7.75" x 2.50" (241.3 x 196.8 x 63.5mm)
3. Compatible with a variety of Peerless-AV pull-out and articulating wall mounts (SP850-UNL, FPS-1000, SA752PU, SA761PU, SA763PU, SA771PU – ACC950 Accessory spacer kit required; contact Customer Care)
4. Offers direct wall mount option with single-stud attachment
5. Nylon belt strap holds media player securely in place inside mount
6. Prop-open access for service

**Mounting Surface:** Wood stud, concrete and cinder block

**Max Load:** See Peerless-AV compatible product selection  
**Ship Weight:** 15lb (6.8kg)  
**Color:** Black

**DS334** Media Player Mounting Bracket

1. Accommodates media players up to 16.75" (425mm) high and up to 4.25" (108mm) deep
2. Designed to quickly attach to a variety of Peerless-AV mounting solutions (PLP adapter plates, SF/ST630-640 and SF/ST16D/24D models)
3. Flexible housing area expands to fit a variety of media player shapes and sizes
4. Open-air design ensures ample airflow to the media player to prevent overheating

**Max Load:** 75lb (34kg)  
**Ship Weight:** 19.9lb (9kg)  
**Color:** Black

**DS495** Media Player Mounting Plate for Apple Mac Mini Computer and AC Power Adapter

1. Attachment angles allow for efficient and discrete placement to undersurfaces, walls, mounts and locations where fasteners are used
2. Complete enclosure provides safety and security
3. Slide cover in back of unit allows for quick access
4. Ventilation slots allow for airflow to prevent overheating

**Mounting Surface:** Wood stud, concrete, cinder block and metal stud (metal stud hardware included)

**Max Load:** 10lb (4.55kg)  
**Ship Weight:** 8.09lb (3.68kg)  
**Color:** Black

**DSX200** Shelf Bracket for Media Devices

1. For media devices up to 18"W x 15"D (457 x 381mm)
2. Shelf can be mounted above or below the display
3. Adjustable shelf is easily moved vertically and horizontally
4. Safety belt secures media devices for added support

**Max Load:** 25lb (11kg)  
**Ship Weight:** 15.2lb (6.9kg)  
**Color:** Black



To verify mount compatibility with any flat panel display or projector model use MountFinder™ at [www.peerless-av.com](http://www.peerless-av.com)



## HOSPITALITY MOUNTS TABLE OF CONTENTS

### Set Top Box Storage Mounts ..... Pull-out Swivel Wall Mount

**LT-320 Model**  
Flat/Tilt Wall Mount for 26" to 32" Flat Panel Displays ..... pg# 185

**HT642-002 Model**  
Flat/Tilt Wall Mount for 32" to 50" Flat Panel Displays ..... pg# 185

**HT642 Model**  
Flat/Tilt Wall Mount for 37" to 50" Flat Panel Displays ..... pg# 185

**PT-420A Model**  
Flat/Tilt Wall Mount for 37" to 60" Flat Panel Displays ..... pg# 185

**HF646-C52 – HF646-C63 Models**  
Flat Wall Mount with Cam Lock Security  
for 32" to 46" Flat Panel Displays ..... pg# 185

**FPS-1000 Models**  
Pull-out Swivel Wall Mount for 26" to 60" Flat Panel Displays ..... pg# 186

### Desktop Swivel Mounts ..... Security Kits

**HP450/HP442 Models**  
Desktop Swivel Mount for up to 52" Flat Panel Displays ..... pg# 187

**FLD-UNV/HLC-KIT Models**  
Display Base Lock-down Security Kits ..... pg# 188



# HOSPITALITY



-  **CALL:** 630-375-5100  
800-865-2112
-  **FAX:** 630-820-8537  
800-359-6500
-  **E-MAIL:**  
info@peerless-av.com
-  **ONLINE:**  
www.peerless-av.com





# Set Top Box Storage Mounts

For 26" to 60" Flat Panel Displays



## LT-320 Flat/Tilt Wall Mount for 26" to 32" Flat Panel Displays

1. VESA® 100 x 100 and 200 x 100mm compliant
2. Flat and tilt (+15°/-2°) wall mount functionality
3. Simple hook-and-hang design allows for an easy installation
4. Clean profile design hides cables and hardware within enclosed wall plate for a clutter-free installation
5. Measures 2.53" (64mm) distance from the wall

**Mounting Surface:** Wood stud, concrete, cinder block and metal stud (metal stud accessory, ACC415 required)

**Max Load:** 80lb (36kg)  
**Ship Weight:** 11lb (4.99kg)  
**Color:** Black



## HT642-002 Flat/Tilt Wall Mount for 32" to 50" Flat Panel Displays

1. VESA® 200 x 100, 200 x 200 and 400 x 200mm compliant
2. Flat and tilt (+5°/-1°) wall mount functionality
3. Simple hook-and-hang design allows for an easy installation
4. Clean profile design hides cables and mount within enclosed wall plate for clutter-free installation
5. Adjustable adapter plate prevents the mount from blocking critical connection points on the back of the display

**Mounting Surface:** Wood stud, concrete, cinder block and metal stud (metal stud hardware included)

**Max Load:** 75lb (34kg)  
**Ship Weight:** 9.8lb (4.4kg)  
**Color:** Black



## HT642 Flat/Tilt Wall Mount for 37" to 50" Flat Panel Displays

1. VESA® 400 x 400mm compliant
2. Flat and tilt (+5°/-1°) wall mount functionality
3. Simple hook-and-hang design allows for an easy installation
4. Clean profile design hides cables and mount within enclosed wall plate for clutter-free installation
5. Open wall plate for total access, increasing electrical and cable management options

**Mounting Surface:** Wood stud, concrete, cinder block and metal stud (metal stud hardware included)

**Max Load:** 100lb (45kg)  
**Ship Weight:** 13.76lb (6.2kg)  
**Color:** Black



## PT-420A Flat/Tilt Wall Mount for 37" to 60" Flat Panel Displays

1. VESA® 600 x 400mm compliant
2. Flat and tilt (+5°/-2°) wall mount functionality
3. Simple hook-and-hang design allows for an easy installation
4. Clean profile design hides cables and hardware within enclosed wall plate for a clutter-free installation
5. Open wall plate for total access, increasing electrical and cable management options

**Mounting Surface:** Wood stud, concrete, cinder block and metal stud (metal stud accessory, ACC415 required)

**Max Load:** 100lb (45kg)  
**Ship Weight:** 19lb (8.62kg)  
**Color:** Black



## HF646-C52 – HF646-C63 Flat Wall Mount with Cam Lock Security for 32" to 46" Flat Panel Displays

1. VESA® 200 x 100 and 200 x 200mm compliant
2. Cam lock security prevents tampering or theft with uniquely keyed security cam locks
3. Simple hook-and-hang design allows for an easy installation
4. Clean profile design hides cables and mount within enclosed wall plate for clutter-free installation
5. Open wall plate for total access, increasing electrical and cable management options

**Mounting Surface:** Wood stud, concrete, cinder block and metal stud (metal stud hardware included)

**Max Load:** 80lb (36kg)  
**Ship Weight:** 8.46lb (3.84kg)  
**Color:** Black



To verify mount compatibility with any flat panel display or projector model use MountFinder™ at [www.peerless-av.com](http://www.peerless-av.com)



**CALL:** 630-375-5100  
800-865-2112



**FAX:** 630-820-8537  
800-359-6500



**E-MAIL:**  
[info@peerless-av.com](mailto:info@peerless-av.com)



**ONLINE:**  
[www.peerless-av.com](http://www.peerless-av.com)



# Pull-out Swivel Wall Mount

For 26" to 60" Flat Panel Displays

## MODELS

**Dedicated Models:** 26" to 60" displays

Screen adapter purchased separately for non-VESA® displays\*  
Includes theft resistant hardware for attaching display to mount  
**FPS-1000** Black

\*Dedicated adapter plates come in flat black and include security fasteners

## DISPLAY ADAPTER

**VESA® Pattern**

**Dedicated Models:** 100 x 100 and 200 x 100mm  
Non-VESA® compliant displays require display-specific adapter to be purchased separately.

## SPECIFICATIONS

**Distance from Wall**

2.16"-10.53" (55-267mm)

**Swivel | Roll**

±45° | ±1°

**Max Load**

150lb (68kg)

**Product Dimensions (W x H x D)**

21.00" x 9.64" x 2.16"-10.53"  
(533 x 245 x 55-267mm)

**Mounting Surfaces**

Wood studs, concrete  
and cinder block

**Ship Weight**

20lb (9.07kg)

## CERTIFICATIONS



## ACCESSORIES



**WSP816/WSP820/WSP824:**  
Metal Stud Wall Plates ..... pg# 196

1. VESA® 100 x 100 and 200 x 100mm compliant
2. Non-VESA adapter plate also available
3. Ideal for wall mount applications and attachment to false backsplashes
4. Built-in swivel up to 90° (45° each direction) allows for adjustable viewing angles
5. Roll can be adjusted 1° clockwise or counterclockwise
6. Easy pull-out swivel provides quick maintenance access
7. Includes security lock out screw to eliminate pull out ability
8. Security screws prevent tampering and theft

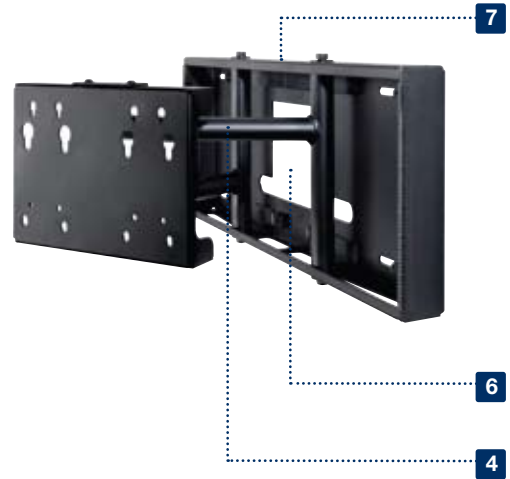

Patented

## TECHNICAL DRAWINGS

For expanded product information and technical data visit [www.peerless-av.com](http://www.peerless-av.com)

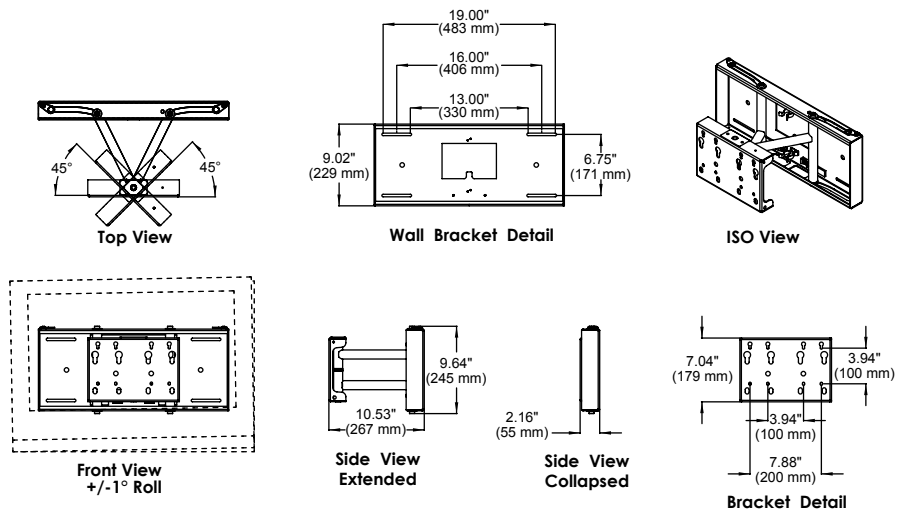

To verify mount compatibility with any flat panel display or projector model use MountFinder™ at [www.peerless-av.com](http://www.peerless-av.com)



# Desktop Swivel Mount

For up to 52" Flat Panel Displays

1. Built in swivel up to 360° allows for optimum viewing angle
2. Base stand bolts down for safety and security
3. Adjustable height allows for greater flexibility
4. Cable management internally through the mount and down through the mounting surface
5. Decorative base is aesthetically pleasing and hides desktop mounting hardware
6. HP442: built in adapter plate is VESA® 200 x 100 and 200 x 200mm compliant
7. HP442: depth of the adapter plate allows for access to the jack inputs on the backside of the display
8. HP450(-S)(-GB): universal and VESA® adapter plate included
9. Security screws prevent tampering and theft



HP450(-S)(-GB)



HP442

For expanded product information and technical data visit [www.peerless-av.com](http://www.peerless-av.com)

## TECHNICAL DRAWINGS

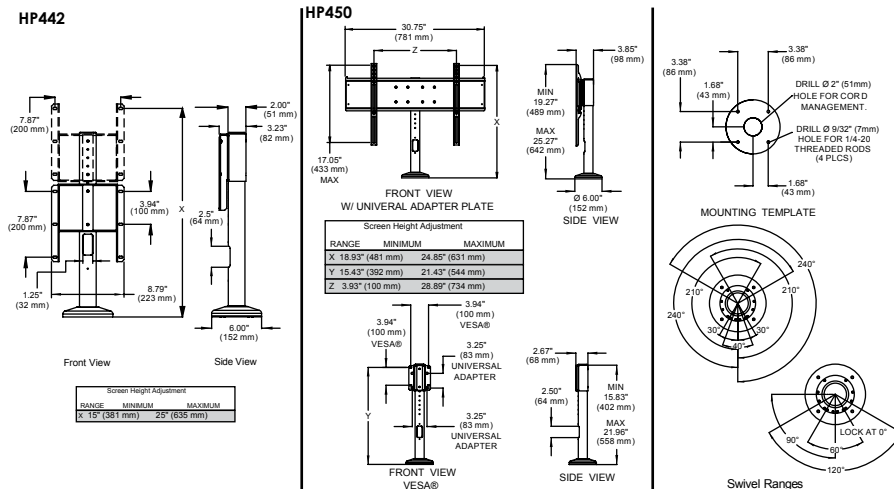

To verify mount compatibility with any flat panel display or projector model use MountFinder™ at [www.peerless-av.com](http://www.peerless-av.com)



CALL: 630-375-5100  
800-865-2112



FAX: 630-820-8537  
800-359-6500



E-MAIL: [info@peerless-av.com](mailto:info@peerless-av.com)



ONLINE: [www.peerless-av.com](http://www.peerless-av.com)



Hospitality

## MODELS

### Universal Models:

Includes theft resistant hardware for attaching display to mount

<b>HP450</b>	For 32" to 52" Displays	Black
<b>HP450-S</b>	For 32" to 52" Displays	Silver
<b>HP450-GB</b>	For 32" to 52" Displays	Gloss black
<b>HP442</b>	For 32" to 42" Displays	Black

## DISPLAY ADAPTER



### Mounting Pattern

HP450(-S)(-GB):	729 x 433mm (28.7"W x 17.05"H)
-----------------	-----------------------------------



### VESA® Pattern

HP442:	200 x 100 and 200 x 200mm
--------	---------------------------

## SPECIFICATIONS



### Swivel

360° of swivel with stops at 40°, 60°, 120°, 180°, 210° and 240°



### Max Load

150lb (68kg)

### Product Dimensions (W x H x D)

HP450(-S)(-GB):	30.75" x 26.50" x 6.00" (781 x 673 x 152mm)
HP442:	8.80" x 21.90" x 6.00" (224 x 556 x 152mm)

### Mounting Surfaces

Desktop

### Ship Weight



HP450(-S)(-GB):	Box 1: 14lb (6.35kg)
	Box 2: 14lb (6.35kg)

HP442:	15.5lb (7.03kg)
--------	-----------------

## CERTIFICATIONS



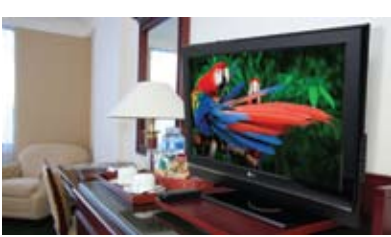

# Display Base Lock-down Security Kits

For select display base stands and VESA® compliant displays

## MODELS

### Universal Models:

Includes theft resistant hardware for attaching display to mount

<b>FLD-UNV</b>	Black	
<b>FLD-UNV-S</b>	Silver	
<b>HLC-KIT</b>	Black	
<b>HLC-KIT-Q10</b>	Black	10-pack

## SPECIFICATIONS

### Max Load

100lb (45.3kg)

### Product Dimensions (W x H x D)

FLD-UNV(-S): 2.00" x 1.00" x 5.00"  
(50.8 x 25.4 x 127mm)

HLC-KIT(-Q10): 30.00" (762mm)

### Mounting Surfaces

Wood surface

### Ship Weight

FLD-UNV(-S): 0.6lb (.27kg)  
HLC-KIT: 0.6lb (.27kg)  
HLC-KIT-Q10: 4lb (1.81kg)

## CERTIFICATIONS



### FLD-UNV(-S)

1. Brackets quickly fasten to the bottom of a variety of display base stands
2. Securely mounts to wood surfaces with tamper resistant hardware
3. Low-profile clips remain hidden when installed
4. Available in black or silver to match the display or desktop surface



FLD-UNV(-S)

### HLC-KIT(-Q10)

1. Compliant with all VESA® mounting hole patterns
2. Secures to virtually any wood surface
3. Neck security fasteners included for securing display to base stand

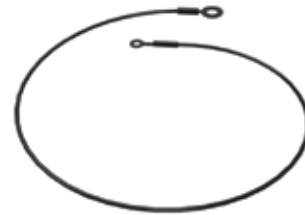

HLC-KIT(-Q10)

## TECHNICAL DRAWINGS

For expanded product information and technical data visit [www.peerless-av.com](http://www.peerless-av.com)

### FLD-UNV

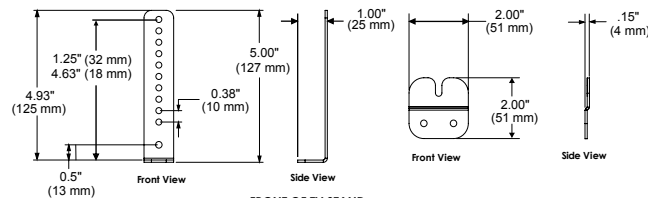

### FRONT OF TV STAND

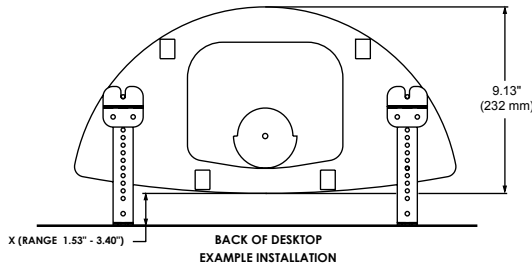

### BACK OF DESKTOP EXAMPLE INSTALLATION

### HLC-KIT

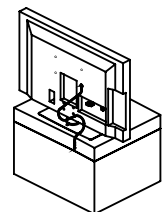
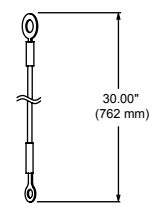

### EXAMPLE INSTALLATION

To verify mount compatibility with any flat panel display or projector model use MountFinder™ at [www.peerless-av.com](http://www.peerless-av.com)



CALL: 630-375-5100  
800-865-2112



FAX: 630-820-8537  
800-359-6500



E-MAIL:  
[info@peerless-av.com](mailto:info@peerless-av.com)



ONLINE:  
[www.peerless-av.com](http://www.peerless-av.com)

## MOUNTING ACCESSORIES TABLE OF CONTENTS

### Mount Accessories

<b>ACCXT100 / ACCXT101</b> Left & Right Speaker Accessory Mount .....	pg# 189
<b>ACCXT200 / ACCXT201</b> Soundbar and Center Channel Accessory Mount....	pg# 189
<b>ACCXT300 / ACCXT301</b> Video Conferencing Shelf Accessory .....	pg# 189
<b>ACCXT302</b> Video Conferencing Shelf Accessory .....	pg# 189
<b>ACC953/ ACC955</b> Component Shelf Accessory .....	pg# 189
<b>ACC-SB</b> Soundbar/Center Channel Accessory Mount .....	pg# 189
<b>ACCXT400 / ACCXT402</b> Recessed Power Outlet with Low Voltage In-Wall Cable Routing .....	pg# 189

### Ceiling Plates & Accessories

<b>CMJ470, CMJ471, CMJ480, CMJ490 Models</b> Ceiling Plates .....	pg# 190
<b>ACC120 Model</b> Internal Joist Mount .....	pg# 190
<b>ACC570 Models</b> Round Ceiling Plate .....	pg# 190
<b>ACC560 Model</b> Ceiling Plate .....	pg# 190
<b>ACC556 Model</b> Cathedral Ceiling Adapter .....	pg# 190
<b>ACC912 Model</b> Lightweight Cathedral Ceiling Adapter .....	pg# 190
<b>ACC840, ACC845 Models</b> Anti-vibration Ceiling Plates .....	pg# 190
<b>CMJ300, CMJ310 Models</b> Unistrut® and Structural Ceiling Plate.....	pg# 190
<b>ACC550 Model</b> Unistrut® Adapter for Truss Ceiling.....	pg# 190
<b>ACC558, ACC559 Models</b> I-beam Clamps .....	pg# 191
<b>ACC557 Model</b> Truss Ceiling Adapter .....	pg# 191
<b>DCS200 Model</b> Structural Ceiling Plate with Stress Decoupler .....	pg# 191
<b>DCT100 Model</b> Truss Ceiling Adapter with Stress Decoupler .....	pg# 191
<b>ACC600 Model</b> Multi-display Interface Bracket.....	pg# 191
<b>DCT500, DCT600, DCT700, DCT800, DCT900 Models</b> Multi-display I-beam Clamps .....	pg# 191
<b>DCT300 Model</b> Multi-display Truss Ceiling Stress Decoupler .....	pg# 191
<b>DCS400 Model</b> Multi-display Structural Ceiling Stress Decoupler.....	pg# 191
<b>PB-1 Model</b> Plenum Box for CMJ450/453/455/500 .....	pg# 191
<b>CMJ450 Model</b> Suspended Ceiling Plate .....	pg# 192
<b>CMJ453 Model</b> Variable Position Suspended Ceiling Kit .....	pg# 192
<b>CMJ455 Model</b> Lightweight Suspended Ceiling Kit .....	pg# 192
<b>CMJ500R1 Model</b> Lightweight Adjustable Suspended Ceiling Plate.....	pg# 192
<b>ACC455 Model</b> Accessory Pack for CMJ455 .....	pg# 192

### Extensions & Accessories

<b>ACC109 Model</b> Extension Column Connector .....	pg# 193
<b>ACC575 Models</b> Threaded Connector Accessory .....	pg# 193
<b>ACC800, ACC850 Models</b> Connector with Cord Management .....	pg# 193
<b>EXT Models</b> Fixed Length Extension Column .....	pg# 193
<b>AEC Models</b> Adjustable Extension Column .....	pg# 193
<b>ALU Models</b> Adjustable Aluminum Extension Column .....	pg# 193
<b>ACC050 Model</b> Extension Column Stabilizer Kit .....	pg# 194
<b>ACC830 Model</b> Side-to-side Adjuster .....	pg# 194
<b>ACC810 Model</b> Threaded Rod Adapter.....	pg# 194
<b>ACC-EXC Models</b> Extension Column for EXC Extension Kit .....	pg# 194
<b>ACC640 Models</b> Escutcheon Ring.....	pg# 194
<b>ACC852, ACC856 Models</b> Cord Wrap.....	pg# 194
<b>EXA/B/C Models</b> Ceiling/Wall Extension Kit for use with PRG/PRS-UNV Projector Mounts.....	pg# 194
<b>ADD Models</b> Multi-display™ Extension Column (Fixed Extension Columns for Ceiling Decouplers) .....	pg# 194
<b>ADD Models</b> Multi-display™ Extension Column (Adjustable Extension Columns for Ceiling Decouplers).....	pg# 194

### Arms & Wall Plates

<b>WSP415 Model</b> Concrete Wall Plate .....	pg# 195
<b>ACC170 Model</b> Rotational Mount Interface Cart and Stand Adapter Plate.....	pg# 195
<b>ACC937 Model</b> M10 Mounting Hole Adapters .....	pg# 195
<b>ACC604/MIS735 Models</b> Dual-display Cartridge .....	pg# 195
<b>WBK100 Models</b> Short Throw Double Stud Wall Plate .....	pg# 195
<b>PWA-14 Models</b> Projector Wall Arm .....	pg# 195
<b>WMJ018, WMJ022, WMJ025H Models</b> Wall Arms.....	pg# 195
<b>WSP716, WSP724 Models</b> Metal Stud Wall Plate - Triple Stud.....	pg# 195
<b>WSP700/WSP701 Models</b> Metal Stud Wall Plates for use with Peerless-AV single stud arms.....	pg# 195
<b>WSP756 Model</b> Metal Stud Wall Plate for SA752P(U), SA761P(U), SA763PU and SA771P(U) .....	pg# 195

### Wall Plates & Hardware

<b>ACC605 Model</b> Wall Hardware for IWB600-SB .....	pg# 196
<b>ACC610 Model</b> Wall Hardware for IWB600-UNIV .....	pg# 196
<b>WSP816/820/824 Models</b> Metal Stud Wall Plate for FPS-1000 and SP850 .....	pg# 196
<b>WSP425/445 Models</b> Metal Stud Wall Plates - Double Stud .....	pg# 196
<b>WSP450/460/470 Models</b> Metal Stud Wall Plates - Triple Stud .....	pg# 196
<b>ACC625/630 Models</b> Dedicated Wall Adapter Box .....	pg# 196
<b>ACC230/233/234, ACC240/243/244 Models</b> Concrete Anchors .....	pg# 196
<b>ACC215, ACC415, ACC615 Models</b> Metal Stud Fastener Kit .....	pg# 196
<b>ACC200, ACC205, ACC210, ACC255 Models</b> Concrete Expansion Anchors .....	pg# 196

continue...

**peerless-AV™**

 **CALL:** 630-375-5100  
800-865-2112

 **FAX:** 630-820-8537  
800-359-6500

 **E-MAIL:**  
info@peerless-av.com

 **ONLINE:**  
www.peerless-av.com

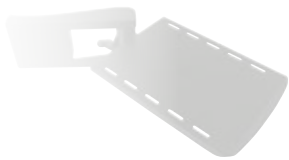

In-wall  
Accessories Boxes

**IBA2(-W)**  
In-Wall Accessories Box..... pg# 197

**IBA2AC(-W)**  
In-Wall Accessories Box  
with 125V Duplex Power Receptacle..... pg# 197

**IBA3(-W)**  
In-Wall Accessories Box..... pg# 197

**IBA3AC(-W)**  
In-Wall Accessories Box  
with 125V Duplex Power Receptacle..... pg# 197

**IBA4-W**  
In-wall Accessories Box  
with 125V Duplex Power Receptacle..... pg# 197

**IBA5-W**  
In-wall Accessories Box  
with 125V Duplex Power Receptacle..... pg# 197

Shelves & Casters

**ACC313 Model**  
Metal Shelf..... pg# 198

**ACC314 Model**  
Laptop Arm..... pg# 198

**ACC317, ACC318 Models**  
Tempered Glass Shelf..... pg# 198

**ACC833 Model**  
Equipment Accessory Shelf..... pg# 198

**ACC324 Models**  
Corner Mount Shelf..... pg# 198

**ACC315 Model**  
Base Shelf..... pg# 198

**ACC330 Model**  
AV Component Shelf for FPZ-640..... pg# 198

**ACC319 Model**  
Video Conferencing Shelf..... pg# 198

**ACC328 Model**  
Laptop Tray..... pg# 198

**ACC325 Model**  
Accessory Shelf for FPZ-600..... pg# 198

**ACC332 Model**  
Casters for FPZ-640..... pg# 198

**ACC310 Model**  
Feet Accessory..... pg# 198

Security & Safety

**ACC320 Model**  
Electrical Outlet Strip with Cord Wrap..... pg# 199

**ACC666 Model**  
Safety Belt..... pg# 199

**ACC952 Model**  
Above Display SUF Security Lock Accessory..... pg# 199

**ACC316 Model**  
Safety Belt..... pg# 199

**ACC954 Model**  
Theft resistant security kit  
for the PTM400 and PTM200..... pg# 199

**ACC111 Model**  
Safety Belt..... pg# 199

**ACC918, ACC919, ACC925 Models**  
Security Fasteners for Wall Arms..... pg# 199

**ACC502 Model**  
Security Fasteners..... pg# 199

**ACC930 Model**  
Fastener Kit for Speaker Mounts..... pg# 199

**ACC016 Model**  
Oversized Roll-out Protectors..... pg# 199

**ACC103, ACC104 Models**  
Bumper Guards..... pg# 199

**OP-ACC307 Model**  
Fasteners for OSHPD compliant installations  
into cinder block walls..... pg# 199

Enclosure  
Accessories

**FPEPM Models**  
Pedestal Mount  
for Peerless-AV Protective Enclosures..... pg# 200

**FPECMC Models**  
Concrete Ceiling Mount  
for Peerless-AV Protective Enclosures..... pg# 200

**FPECFI Models**  
I-Beam Mount  
for Peerless-AV Protective Enclosures..... pg# 200

**FPEWM Model**  
Tilt Wall Mount  
for Peerless-AV Protective Enclosures..... pg# 200



## ACCXT100 / ACCXT101 *Left and Right Speaker Accessory Mount*

1. Left and right speaker accessory mount for pivot and articulating mounts
2. Pivots, tilts and articulates with the flat panel display
3. Adjustable height and depth
4. ACCXT100 compatible with SmartMountXT™ SAX mounts
5. ACCXT101 compatible with PP/PA/SP/SA740(P)

**Max Load:** ACCXT100 15lb (6.8kg)  
ACCXT101 10lb (4.54kg)  
**Color:** Black



## ACCXT200 / ACCXT201 *Soundbar and Center Channel Accessory Mount*

1. Soundbar and center channel accessory mount for pivot and articulating mounts
2. Pivots, tilts and articulates with flat panel display
3. Adjustable width
4. ACCXT200 compatible with SmartMountXT™ SAX mounts
5. ACCXT201 compatible with PP/PA/SP/SA740(P)

**Max Load:** ACCXT200 25lb (11.34kg)  
ACCXT201 10lb (4.54kg)  
**Color:** Black



## ACCXT300 / ACCXT301 *Video Conferencing Shelf Accessory*

1. Can be mounted above or below display
2. Pivots, tilts and articulates with flat panel display
3. ACCXT300 compatible with SmartMountXT™ SAX mounts
4. ACCXT301 compatible with PP/PA/SP/SA740(P) mounts
5. Opening for cable management
6. Adjustable height

**Max Load:** 5lb (2.27kg)  
**Color:** Black



## ACCXT302 *Video Conferencing Shelf Accessory*

1. Can be mounted above or below display
2. Tilts with flat panel display
3. Compatible with SmartMountXT™ flat and tilt mounts
4. Opening for cable management
5. Adjustable height

**Max Load:** 5lb (2.27kg)  
**Color:** Black



## ACC953 / ACC955 *Component Shelf Accessory*

1. Pivots, tilts and articulates with flat panel display
2. Adjustable width
3. ACC953 compatible with SmartMountXT™ SAX mounts
4. ACC955 compatible with PP/PA/SP/SA740(P)

**Max Load:** 15lb (6.8kg)  
**Color:** Black



## ACC-SB *Soundbar/Center Channel Accessory Mount*

1. Compatible with SUA746PU, SUA751PU and SUA765PU mounts
2. Simple installation
3. Adjustable height
4. Post-installation leveling
5. Adds zero depth to installation
6. Opening for cable management

**Max Load:** 25lb (11.34kg)  
**Ship Weight:** 3.5lb (1.59kg)  
**Color:** Gloss Black



## ACCXT400 / 402 *Recessed Power Outlet with Low Voltage In-Wall Cable Routing*

1. Low-profile design fits neatly into the SAX, SFX and STX wall plate without adding any depth to the mount
2. Routes low voltage component cables inside the wall
3. 15Amp/125 Volt duplex power receptacle power source with surge suppressor protection
4. ACCXT400 compatible with SmartMountXT™ SAX762PU and SAX772PU mounts
5. ACCXT402 compatible with SmartMountXT™ flat and tilt mounts

**Color:** Black



## CMJ470(W), CMJ471, CMJ480, CMJ490 Ceiling Plates

1. Mounts to wood joists or structural concrete ceiling (requires concrete anchors ACC234/ACC244, sold separately)
2. 1.5"-11.5 NPT (38mm) fitting for attachment of extension column

**CMJ470(W):** for 16" (406mm) joist centers  
**CMJ471:** for 16" (406mm) joist centers  
**CMJ480:** for 20" (508mm) joist centers  
**CMJ490:** for 24" (609mm) joist centers

**Max Load:** 300 lb (136 kg)  
**Ship Weight:** **CMJ470** 3.2lb (1.4kg)  
**CMJ471** 4.3lb (2kg)  
**CMJ480** 4.8lb (2.2kg)  
**CMJ490** 5.7lb (2.6kg)

**Color:** Black or white (CMJ470W only)



## ACC120 Internal Joist Mount

1. Expandable to mount between two wood joists from 16" to 20" (406-508mm) centers
2. Attachment point for extension column may be positioned at any point within 2-3/4" (69mm) of either joist
3. 1.5"-11.5 NPT (38mm) fitting for attachment of extension column

**Max Load:** 300lb (136kg)  
**Ship Weight:** 8lb (3.6kg)  
**Color:** Black



## ACC570(S)(W) Round Ceiling Plate

1. Mounts to wood joist or structural ceiling (requires concrete anchor ACC233 or ACC200, sold separately)
2. Cable management access hole
3. 1.5"-11.5 NPT (38mm) fitting for attachment of extension column

**Max Load:** 150lb (68kg)  
**Ship Weight:** 1.7lb (.8kg)  
**Color:** Black, silver or white



## ACC560 Ceiling Plate

1. Mounts to wood joist, structural ceiling or concrete
2. Low-profile design ideal for small displays and projector installations
3. 1.5"-11.5 NPT (38mm) fitting for attachment of extension column

**Max Load:** 50lb (22kg)  
**Ship Weight:** 0.93lb (.4kg)  
**Color:** Black



## ACC556 Cathedral Ceiling Adapter

1. Mounts to cathedral or vaulted ceilings
2. 120° (+60°) of adjustment
3. 1.5"-11.5 NPT (38mm) fitting for attachment of extension column

**Max Load:** 300lb (136kg)  
**Ship Weight:** 4.6lb (2.1kg)  
**Color:** White



## ACC912 Lightweight Cathedral Ceiling Adapter

1. Mounts to cathedral or vaulted ceilings
2. 120° (±60°) of adjustment
3. Compact, lightweight and easy to install

**Max Load:** 75lb (34kg)  
**Ship Weight:** 1.9lb (.9kg)  
**Color:** Black



## ACC840, ACC845 Anti-vibration Ceiling Plates

1. Reduces vibrations that may cause internal damage to equipment and/or cause display image to vibrate
2. Features two cord management access holes
3. 1.5"-11.5 NPT (38mm) fitting for attachment of extension column

**ACC840:** for wood joist ceiling  
**ACC845:** for Unistrut ceiling 1.625" x 1.625" (41 x 41mm) 12 gauge Unistrut

**Max Load:** 60lb (27kg)  
**Ship Weight:** **ACC840:** 3lb (1.4kg)  
**ACC845** 4lb (1.8kg)  
**Color:** Black



## CMJ300, CMJ310 Unistrut® and Structural Ceiling Plate

1. Attaches directly to standard Unistrut 1.625" x 1.625" (41 x 41mm) or to solid structural ceiling
2. Unistrut fittings and attachment hardware not included
3. 1.5"-11.5 NPT (38mm) fitting for attachment of extension column

**Max Load:** 250lb (113kg)  
**Ship Weight:** **CMJ300** 2lb (.9kg)  
**CMJ310** 4lb (1.8kg)  
**Color:** Black



## ACC550 Unistrut® Adapter for Truss Ceiling

1. For use with 1.625" x 1.625" (41 x 41mm), 12 gauge Unistrut
2. 1.5"-11.5 NPT (38mm) fitting for attachment of extension column

**Max Load:** 250lb (113kg)  
**Ship Weight:** 1.4lb (.6kg)  
**Color:** Black



## ACC558, ACC559

### I-beam Clamps

- 1.5"-11.5 NPT (38mm) fitting for attachment of extension column

**ACC558:** for 4"-8" (101-203mm) wide, 0.25" to 1" (6-25mm) thick I-Beam  
**ACC559:** for 7"-12" (177-304mm) wide, 0.25" to 1" (6-25mm) thick I-Beam

**Max Load:** 250 lb (113 kg)  
**Ship Weight:** **ACC558** 4.8lb (2kg)  
**ACC559** 5.3lb (2.4kg)  
**Color:** Black



## ACC557

### Truss Ceiling Adapter

1. Attaches to a round square, rectangular, or I-Beam truss up to 3" (76mm) wide x 3.5" (89mm) high
- 1.5"-11.5 NPT (38mm) fitting for attachment of extension column

**Max Load:** 1,200lb (544kg)  
**Ship Weight:** 3lb (1.4kg)  
**Color:** Black



## DCS200 Structural Ceiling Plate with Stress Decoupler

1. Includes structural ceiling plate with integral high density rubber decoupler assembly to prevent vibrations
2. Mounts to concrete beam, slab or other structural member
- 1.5"-11.5 NPT (38mm) fitting for attachment of extension column

**Max Load:** 300lb (136kg)  
**Ship Weight:** 6lb (2.7kg)  
**Color:** Black



## DCT100 Truss Ceiling Adapter with Stress Decoupler

1. Includes truss ceiling plate with integral high density rubber decoupler assembly to prevent vibrations
2. Attaches to round, square, rectangular or I-beam trusses up to 3" (76mm) wide x 3.5" (89mm) high
- 1.5"-11.5 NPT (38mm) fitting for attachment of extension column

**Max Load:** 300lb (136kg)  
**Ship Weight:** 4lb (1.8kg)



## ACC600

### Multi-display Interface Bracket

1. Suspends flat panel display mount from extension column to in-line, curvilinear and circular MDJ multi-display configurations
2. For use with EXT or ADJ model extension columns
3. For other applications that require mounting from pipe larger than 2" (50mm) in diameter, use ACC557

**Max Load:** 1200lb (544kg)  
**Ship Weight:** 3.8lb (1.7kg)  
**Color:** Black



## DCT500, DCT600, DCT700, DCT800, DCT900 Multi-display I-beam Clamps

1. For use only with Peerless-AV Multi-Display Systems in combination with Adjustable Length Extension Columns (ADD models)
2. Includes structural ceiling plate with integral high density rubber decoupler assembly to prevent vibrations

**DCT500:** for 7"-12" (177-304mm) wide, 0.25"-1" (6-25mm) thick I-beams  
**DCT600:** for 15"-19.5" (381-495mm) wide, 1.5"-2" (38-50mm) thick I-beams  
**DCT700:** for 15"-19.5" (381-495mm) wide, 2.5"-3" (63-76mm) thick I-beams  
**DCT800:** for 7"-12" (177-304mm) wide, 2.5"-3" (63-76mm) thick I-beams  
**DCT900:** for 4"-7" (101-177mm) wide, up to 1.5" (38mm) thick I-beams

**Max Load:** 600lb (272kg)  
**Ship Weight:** **DCT500** 9.4lb (4.3kg)  
**DCT600** 13.1lb (6kg)  
**DCT700** 13.6lb (6.2kg)  
**DCT800** 14lb (6.4kg)  
**DCT900** 9lb (4.1kg)  
**Color:** Black



## DCT300 Multi-display Truss Ceiling Stress Decoupler

1. Includes truss ceiling plate with integral high density rubber decoupler assembly to prevent vibrations
2. Attaches to round, square, rectangular or I-beam trusses up to 3" (76mm) wide x 3.5" (89mm) high
3. Stub fitting accepts adjustable or fixed length ADD model extension columns

**Max Load:** 1,200lb (544kg)  
**Ship Weight:** 4.6lb (2.1kg)  
**Color:** Black



## DCS400 Multi-display Structural Ceiling Stress Decoupler

1. Includes structural ceiling plate with integral high density rubber decoupler assembly to prevent vibrations
2. Stub fitting accepts adjustable or fixed length ADD model extension columns

**Max Load:** 1,200lb (544kg)  
**Ship Weight:** 7.8lb (3.5kg)  
**Color:** Black



## PB-1 Plenum Box for CMJ450/453/455/500

1. Simple lockdown with slideable lid and optional lockdown screw
2. 3" (76mm) of lateral adjustment for precise placement
3. 0.5" (13mm), 0.75" (19mm) and 1" (25mm)
4. For all CMJ450 and 453 installations ACC460 is required

**Ship Weight:** 11.28lb (5.12kg)  
**Color:** White



## CMJ450

### Suspended Ceiling Plate

1. Replaces 2' x 2' (609 x 609mm) ceiling tile and secures to structural ceiling with tie wires
2. Includes tie wire supports and ceiling plate with two knockout panels for outlet boxes and antenna leads (knockouts are for half-size handy boxes with flanges)
3. 1.5"-11.5 NPS (38mm) fitting for attachment of extension column

**Max Load:** 250lb (114kg)  
**Ship Weight:** 21.1lb (9.6kg)  
**Color:** White



## CMJ453

### Variable Position Suspended Ceiling Kit

1. Replaces 2' x 2' (609 x 609mm) ceiling tile and secures to structural ceiling with tie wires
2. Two-piece design offers five different points for mount attachment
3. Includes tie wire supports, flush mount tube and offers two knockout panels for outlet boxes
4. 1.5"-11.5 NPS (38mm) fitting for attachment of extension column

**Max Load:** 250lb (114kg)  
**Ship Weight:** 21.4lb (9.7kg)  
**Color:** White



## CMJ455

### Lightweight Suspended Ceiling Kit

1. Replaces a 2' x 2' (609 x 609mm) ceiling tile or mounts above existing 2' x 2' (609 x 609mm) or 2' x 4' (609 x 1219mm) ceiling tile to structural ceiling with tie wires
2. Two-piece design offers five different points for mount attachment
3. Includes tie wire supports, flush mount tube and offers two knockout panels for outlet boxes
4. 1.5"-11.5 NPS (38mm) fitting for attachment of extension column

**Max Load:** 50lb (22kg)  
**Ship Weight:** 14.6lb (6.6kg)  
**Color:** White



## CMJ500R1 Lightweight Adjustable Suspended Ceiling Plate

1. Mounts above 2' x 2' (609 x 609mm) or 2' x 4' (609 x 1219mm) ceiling tile to structural ceiling with tie wires
2. Includes Kwik-Loc™ self locking cable joiners for simple cable support set-up
3. Allows 13.90" (353mm) uninterrupted adjustment

**Max Load:** 60lb (27kg)  
**Ship Weight:** 6.6lb (2.9kg)  
**Color:** White



## ACC455

### Accessory Pack for CMJ455

1. Includes four hanger brackets and four hanger clamps for additional stability
2. For use with model CMJ455

**Ship Weight:** 2lb (.9kg)  
**Color:** Black



### ACC109

#### Extension Column Connector

- Two female connectors to join two extension columns to create maximum length of 20' (6,096mm)
- Unit has 1.5"-11.5 NPT (38mm) fitting for attachment of extension column
- Security screws included

**Max Load:** 1,200lb (544kg)  
**Ship Weight:** 1.1lb (.5kg)  
**Color:** Black



### ACC575(-S)(-W)

#### Threaded Connector Accessory

- Compatible with flat panel display ceiling mounts (PC930A/B/C, PC932A/B/C) and projector mounts (PPA/B/C, PRS and PRG Projector Mount Kits)
- 1.5" (38mm) threaded connector used in various ceiling installations
- Increases drop length when used in conjunction with standard extension column

**Max Load:** 80lb (36kg)  
**Ship Weight:** 0.365lb (0.165kg)  
**Color:** Black, silver or white



### ACC800, ACC850(S)

#### Connector with Cord Management

- 1.5" (38mm) access hole for internal cord management
- Unit has 1.5"-11.5 NPT (38mm) fitting for attachment of extension column
- Security screws included
- ACC800 – One male and one female connection to provide internal cord management between extension column and mount or ceiling plate
- ACC850 – Two female connectors to provide internal cord management and join two extension columns to create maximum height of 20' (6m)

**Max Load:** 300lb (136kg)  
**Ship Weight:** ACC800 0.5 lb (0.2kg)  
 ACC850 0.39 lb (0.17kg)  
**Color:** ACC800 Black  
 ACC850 Black or silver



### EXT Models

#### Fixed Length Extension Columns

- 1.5"-11.5 NPT (38mm) schedule 40 pipe threaded on both ends. Notched for use with screw to provide safety and security
- Extension column lengths measure 3.5" (89mm) longer than stated drop to provide finished drop length for various mounts (i.e. EXT101 measures 15.5" (393mm))

Model	Drop*	Ship Weight
EXT002(S)**	Flush	1lb (0.4kg)
EXT006(S)	6" (15cm)	2.3lb (1kg)
EXT018(S)	18" (46cm)	4lb (1.8kg)
EXT101(S)	1' (0.3m)	3.7lb (1.7kg)
EXT102(S)	2' (0.6m)	6lb (2.7kg)
EXT103(S)	3' (0.9m)	9lb (4.1kg)
EXT104(S)	4' (1.2m)	10lb (4.5kg)
EXT105(S)	5' (1.5m)	15lb (6.8kg)
EXT106(S)	6' (1.8m)	16lb (7.3kg)
EXT107(S)	7' (2.1m)	18lb (8.2kg)
EXT108(S)	8' (2.4m)	20lb (9.1kg)
EXT109(S)	9' (2.7m)	26lb (11.8kg)
EXT110(S)	10' (3.1m)	29lb (13.2kg)

\* Drop length applies to Jumbo 2000® mount installations  
 \*\* For projector installations only

**Max Load:** 1,200lb (544kg)  
**Color:** Black or silver



### AEC Models

#### Adjustable Extension Columns

- 1.5"-11.5 NPT (38mm) schedule 40 pipe threaded on both ends
- Notch design at top for set screw to lock column in place
- Height adjustment at 1" (25mm) increments
- Extension column lengths measure 1" (25mm) longer than stated drop to provide finished drop length for various mounts

Model	Drop	Ship Weight
AEC006009(-S)(-W)	6"-9" (0.15-0.23m)	2.16lb (0.98kg)
AEC012018(-S)(-W)	12"-18" (0.30-0.46m)	3.98lb (1.80kg)
AEC018024 (-S)(-W)	18"-24" (0.46-0.61m)	5.72lb (2.59kg)
AEC0203(-S)(-W)	2'-3" (0.61-0.91m)	7.87lb (3.57kg)
AEC0305(-S)(-W)	3'-5" (0.91-1.52m)	13.01lb (5.90kg)
AEC0406(-S)(-W)	4'-6" (1.22-1.83m)	16.53lb (7.49kg)
AEC0608(-S)(-W)	6'-8" (1.83-2.44m)	22.47lb (10.19kg)
AEC0810(-S)(-W)	8'-10" (2.44-3.05m)	28.42lb (12.89kg)
AEC1012(-S)(-W)	10'-12" (3.05-3.66m)	34.25lb (15.53kg)

**Max Load:** 900lb (408kg)  
**Color:** Black, silver or white



### ALU Models

#### Adjustable Aluminum Extension Columns

- Lightweight for ease of installation ideal solution for lightweight projectors and single display applications
- 1.5"-11.5 NPT (38mm) schedule 40 pipe threaded on both ends
- Notch design at top for set screw to lock column in place
- Height adjustment at 1" (25mm) increments
- Extension column lengths measure 1" (25mm) longer than the stated drop to provide finished drop length for various mounts
- Unobtrusive cable management

Model	Drop	Ship Weight
ALU006009(-S)(-W)	6"-9" (0.15-0.23m)	1.3lb (0.6kg)
ALU0090012(-S)(-W)	9"-12" (0.22-0.30m)	1.6lb (0.7kg)
ALU012018(-S)(-W)	12"-18" (0.30-0.46m)	2.2lb (1kg)
ALU018024(-S)(-W)	18"-24" (0.46-0.61m)	2.9lb (1.3kg)
ALU0203(-S)(-W)	2'-3" (0.61-0.91m)	4.1lb (1.9kg)
ALU0305(-S)(-W)	3'-5" (.91-1.52m)	6.7lb (3.0kg)
ALU0406(-S)(-W)	4'-6" (1.22-1.83m)	9.1lb (4.1kg)
ALU0507(-S)(-W)	5'-7" (1.52-2.13m)	10.4lb (4.7kg)
ALU0608(-S)(-W)	6'-8" (1.83-2.44m)	11.4lb (5.2kg)
ALU0810(-S)(-W)	8'-10" (2.44-3.05m)	13.9lb (6.3kg)
ALU1012(-S)(-W)	10'-12" (3.05-3.66m)	16.0lb (7.3kg)

**Max Load:** 500lb (225kg)  
**Color:** Black, silver or white



To verify mount compatibility with any flat panel display or projector model use MountFinder™ at [www.peerless-av.com](http://www.peerless-av.com)



**CALL:** 630-375-5100  
800-865-2112



**FAX:** 630-820-8537  
800-359-6500



**E-MAIL:**  
[info@peerless-av.com](mailto:info@peerless-av.com)



**ONLINE:**  
[www.peerless-av.com](http://www.peerless-av.com)



### ACC050

#### Extension Column Stabilizer Kit

1. Reduces unwanted swaying that may occur with long drop lengths
2. For use with 1.5" (38mm) schedule 40 extension columns

**Ship Weight:** 2.8lb (1.3kg)  
**Color:** Black



### ACC830

#### Side-to-side Adjuster

1. 4" (101mm) of radial side to side adjustment
2. May be used with extension column or projector wall arm
3. Includes Flush Mount Tube, EXT002

**Max Load:** 50lb (22kg)  
**Ship Weight:** 2lb (.9kg)  
**Color:** Black



### ACC810

#### Threaded Rod Adapter

1. For use with thread rod ACC820
2. Has 1.5" x 11.5 NPT (38mm) male thread for use with Peerless-AV mounts and ceiling accessories
3. Security screws included

**Max Load:** 50lb (22kg)  
**Ship Weight:** 1lb (.5kg)  
**Color:** Black



### ACC-EXC(S)(W) Extension Column for EXC Extension Kit

1. Adds 16" (406mm) of drop to EXC, PRS-EXC and PRG-EXC projector kits
2. Also adds 16" (406mm) extension drop with EXA, EXB, PRS-EXA/B/C and PRG-EXA/B/C
3. Integrated cable management
4. Includes matching wire slot cover

**Max Load:** 50lb (22kg)  
**Ship Weight:** 2.7lb (1.22kg)  
**Color:** Black, silver or white  
Not usable in wall-mounted applications



### ACC640(-B)(-W), ACC002 Escutcheon Ring

1. Covers hole where extension column passes through ceiling
2. Hinged ring wraps around 1.5" (38mm) schedule 40 extension column with ACC640(-B)(-W)
3. Hinged ring wraps around 2" (50mm) schedule 40 extension column with ACC002

**Max Load:** 1200lb (544kg)  
**Ship Weight:** 0.02lb (.09kg)  
**Color:** Chrome, black or white  
**ACC640(-B)(-W):** Chrome, black or white  
**ACC002:** Black



### ACC852(S)(W), ACC856(W) Cord Wrap

1. Designed to externally route cords along outside of extension column
2. Sections can be stacked to create longer lengths or cut to desired length

**ACC852:** Four 2' (609mm) sections  
**ACC856:** Four 6' (1828mm) sections  
**Ship Weight:** **ACC852** 2lb (.9kg)  
**ACC856** 6lb (2.7kg)  
**Color:** Black, silver or white



### EXA/B/C(S)(W) Ceiling/Wall Extension Kit for use with PRG/PRS-UNV Projector Mounts

1. EXA and EXB series for ceiling or wall mounting
2. EXC models for ceiling mounting
3. Integrated cable management
4. Various height adjustments for ideal viewing positions

Model	Extension	Position	Ship weight
EXA/S/W	8.7"-12.8" (220-325mm)	Ceiling	4.6lb (2kg)
EXA/S/W	9.7"-13.8" (246-350mm)	Wall	4.6lb (2kg)
EXB/S/W	12.6"-20.6" (322-523mm)	Ceiling	5lb (2.2kg)
EXB/S/W	13.7"-21.7" (348-551mm)	Wall	5lb (2.2kg)
EXC/S/W	19.1"-32.9" (485-835mm)	Ceiling	6.1lb (2.7kg)

**Max Load:** 50lb (22kg)  
**Color:** Black, silver or white



### ADD Models Multi-display™ Extension Column (Fixed Extension Columns for Ceiling Decouplers)

1. Drop length of final display assembly will vary according to selected decoupler unit. See spec sheet at [www.peerless-av.com](http://www.peerless-av.com) for complete information.

Model	Drop	Ship Weight
ADD101	1' (.3m)	4.6lb (2.1kg)
ADD102	2' (.6m)	7.1lb (3.2kg)
ADD103	3' (.9m)	11.3lb (5.1kg)
ADD104	4' (1.22m)	13.4lb (6.1kg)
ADD105	5' (1.52m)	17.8lb (8.1kg)
ADD106	6' (1.83m)	20.5lb (9.3kg)
ADD107	7' (2.13m)	25.8lb (11.7kg)
ADD108	8' (2.44m)	29.2lb (12.8kg)
ADD109	9' (2.74m)	35.8lb (16.2kg)
ADD110	10' (3.05m)	38.2lb (17.3kg)

**Max Load:** 1,200lb (544kg)  
**Color:** Black

Columns longer than 9' (2.74m) wrapped in vinyl



### ADD Models Multi-display™ Extension Column (Adjustable Extension Columns for Ceiling Decouplers)

1. Drop length of final display assembly will vary according to selected decoupler unit. See spec sheet at [www.peerless-av.com](http://www.peerless-av.com) for complete information.

Model	Drop	Ship Weight
ADD012018	12"-18" (30-46cm)	5lb (2.3kg)
ADD018024	18"-24" (46-61cm)	5.5lb (2.5kg)
ADD0203	2'-3' (0.6-0.9m)	8.2lb (3.7kg)
ADD0305	3'-5' (0.9-1.2m)	13.3lb (6kg)
ADD0406	4'-6' (1.2-1.8m)	16lb (7.3kg)
ADD0507	5'-7' (1.5-2.1m)	21lb (9.5kg)
ADD0608	6'-8' (1.8-2.4m)	22lb (10kg)
ADD0709	7'-9' (2.1-2.7m)	26lb (11.7kg)
ADD0810	8'-10' (2.4-3.1m)	28lb (12.7kg)
ADD0911	9'-11' (2.7-3.4m)	30.3lb (13.7kg)
ADD1012	10'-12' (3.1-3.7m)	34lb (15.4kg)

**Max Load:** 1,200lb (544kg)  
**Color:** Black

Columns longer than 9' (2.74m) wrapped in vinyl



To verify mount compatibility with any flat panel display or projector model use MountFinder™ at [www.peerless-av.com](http://www.peerless-av.com)



## WSP415

### Concrete Wall Plate

1. For cinder block installations
2. Mounts on opposite side of wall from display mount by bolting through wall
3. Mounting hardware not included

**Max Load:** 150lb (68kg)  
**Ship Weight:** 2.3lb (1kg)  
**Color:** Black



## ACC170 Rotational Mount Interface

### Cart and Stand Adapter Plate

1. Required for use of RMI1 with SS550P stand and SR560 cart

**Ship Weight:** 3lb (1.5kg)  
**Color:** Black



## ACC937

### M10 Mounting Hole Adapters

1. Provides compatibility with displays that use M10 mounting screws
2. For use on universal flat, tilt, and articulating products

**Max Load:** 250lb (113kg) on mount  
**Ship Weight:** 2.1lb (.95kg)  
**Color:** Black



## ACC604 / MIS735

### Dual-display Cartridge

1. For use with flat panel display stands
2. For two stacked displays and four-display formation

**ACC604:** For use with FPZ-600  
**MIS735:** For use with FPZ-670

**Ship Weight:** **ACC604** 12.06lb (5.4kg)  
**MIS735** 24lb (10.8kg)

**Color:** Black



## WBK100(-W)

### Short Throw Double Stud Wall Plate

1. For wood stud, 16" (406mm) centers, and concrete or cinder block applications
2. Allows for 6" (152mm) of lateral adjustment
3. Mounting hardware included

**Max Load:** 50lb (22kg)  
**Ship Weight:** 7lb (3.2kg)  
**Color:** Black or white



## PWA-14(S)(W)

### Projector Wall Arm

1. Mounts to single wood stud or concrete wall (requires concrete anchor ACC233/243, sold separately)
2. Offers 14.25" (361mm) reach
3. Includes flush mount adapter

**Max Load:** 50lb (22kg)  
**Ship Weight:** 5lb (2.3kg)  
**Color:** Black, silver or white



## WMJ018, WMJ022, WMJ025H

### Wall Arms

1. 1.5"-11.5 NPT (38mm) threaded fitting accepts flush mount tube or extension column
2. Comes with wood screws

**WMJ018:** Single arm with 18" (457mm) reach  
**WMJ022:** Single Arm with 22.5" (572mm) reach  
**WMJ025H:** Double Arm with 25" (635mm) reach

**Max Load:** **Wood** 125lb (57kg) single arm  
**Concrete** 150lb (68kg) single arm  
**Wood/ Concrete** 300lb (137kg) double arm

**Ship Weight:** **WMJ018** 12lb (5.4kg)  
**WMJ022** 13lb (5.9kg)  
**WMJ025H** 18lb (8.2kg)

**Color:** Black



## WSP716(S)(W)(GB)(GS), WSP724(S)(W)(GB)(GS)

### Metal Stud Wall Plate - Triple Stud

1. Compatible with PLA Series Wall Mount
2. Designed to span the load between three studs
3. Offered with electrical knockouts

**WSP716 Models:** 16" (406mm) centers  
**WSP724 Models:** 16" (406mm), 20" (508mm), 24" (609mm) centers

**Max Load:** 200lb (90kg)

**Ship Weight:** **WSP716 Models** 20.4lb (9.2kg)  
**WSP724 Models** 30.9lb (14kg)

**Color:** Black, High-Gloss Black, Silver, High-Gloss Silver or White



## WSP700/WSP701 Metal Stud Wall Plate

### for use with Peerless-AV single stud arms

1. For use with SA730P, SA735P, SA740P, SA746PU, SP730P, SP735P, SP740P, SP746PU, PA730, PA735F, PA740, PA746F, PP730 and PP740
2. Minimal wall footprint for added wall access and increased cable management options

**Max Load:** 80lb (36kg)  
**Mounting Surface:** **WSP700** 16" Center Metal Studs  
**WSP701** 20" and 24" Center Metal Studs  
**Ship Weight:** **WSP700** 6.5lb (3kg)  
**WSP701** 10.5lb (5kg)

**Color:** Gloss black



## WSP756 Metal Stud Wall Plate for

### SA752P(U) / 761P(U) / 763PU / 771P(U)

1. For use with SA752P(U), SA761P(U), SA763PU and SA771P(U)
2. Increased cable management options

**Max Load:** **for SA752P(U):** 90lb (40.8kg)  
**for SA761P(U):** 130lb (58.9kg)  
**for SA763PU / 771P(U):** 200lb (90.7kg)

**Mounting Surface:** 16", 20" and 24" Center Metal Studs  
**Ship Weight:** 16.5lb (7kg)  
**Color:** Gloss black



## ACC605

Wall Hardware for IWB600-SB

- 4 each security screws, concrete anchors, toggle and washers

Ship Weight: 0.32lb (0.14kg)



## ACC610

Wall Hardware for IWB600-UNIV

- 10 each security screws, concrete anchors, toggle and washers

Ship Weight: 0.50lb (0.22kg)



## WSP816/820/824 Metal Stud Wall Plate for FPS-1000 and SP850

- Compatible with FPS-1000 and SP850
- Designed to span the load between 2 studs

WSP816 16" (406mm) centers  
WSP820: 20" (508mm) centers  
WSP824: 24" (609mm) centers

Max Load: 150lb (68kg) on mount

Ship Weight: WSP816 14.5lb (6.6kg)  
WSP820: 14.5lb (6.6kg)  
WSP824: 15.96lb (7.2kg)

Color: Black or white



## WSP425/445(W)

Metal Stud Wall Plates - Double Stud

- For use on 25 gauge or heavier metal studs to span load between two studs with 16" (406mm), 20" (508mm) or 24" (609mm) centers
- Can also be used on wood studs
- Compatible with most Peerless-AV single wall arms

WSP425(W): 16" (406mm) centers with knockouts

WSP445(W): 24" (609mm) centers with knockouts

Max Load: WSP models 125lb (57kg)

Ship Weight: WSP425(W) 11lb (5kg)  
WSP445(W) 15lb (6.8kg)

Color: WSP models Black or white



## WSP450/460/470

Metal Stud Wall Plates - Triple Stud

- For use on 25 gauge or heavier metal studs to span load between three studs with 16" (406mm), 20" (508mm) or 24" (609mm) centers
- Compatible with most Peerless-AV double wall arms
- Pre-scored electrical knockouts

WSP450: 16" (406mm) centers

WSP460: 20" (508mm) centers

WSP470: 24" (609mm) centers

Max Load: 175lb (79kg)

Ship Weight: WSP450 24.5lb (11.1kg)  
WSP460 30lb (13.6kg)  
WSP470 33.5lb (15.2kg)

Color: Black



## ACC625/630

Dedicated Wall Adapter Box

- Compatible with SMART Arm 600i, SMART UX60 and Hitachi A100WALLARM2
- Mounts to studs 16" on center
- Expandable depth range of 2.14"-3.50" with ACC625 and 3.26"-5.50" with ACC630

Overall Dimensions: (W x H x D)

ACC625: 18.48" x 10.75" x 3.50" (469 x 273 x 89mm)

ACC630: 18.48" x 10.75" x 5.50" (469 x 273 x 139mm)

Max Load: ACC625 60lb (27.2kg)  
ACC630 50lb (22.6kg)

Ship Weight: ACC625 15lb (6.8kg)  
ACC630 17.5lb (7.9kg)

Color: Black



## ACC230/233/234, ACC240/243/244

Concrete Anchors

- For attachment to concrete and concrete block
- ACC233, ACC234, ACC230: 8mm anchor used in conjunction with #14 x 2.5" (63mm) wood screw  
ACC243, ACC244, ACC240: 10mm anchor used in conjunction with #5/16 x 3" (76mm) wood screw

ACC233/243: 3 anchors  
ACC234/244: 4 anchors  
ACC230/ACC240: 50 anchors

Ship Weight:

ACC233/243: 0.05lb (0.02kg)

ACC234/244: 0.05lb (0.22kg)

ACC230/ACC240: 1lb (0.45kg)



## ACC215, ACC415, ACC615

Metal Stud Fastener Kit

- For mounting Peerless-AV wall mounts to 25 gauge or heavier metal studs

ACC215: 2 anchors

ACC415: 4 anchors

ACC615: 6 anchors

Ship Weight: ACC215 0.19lb (0.09kg)

ACC415 0.32lb (0.1kg)

ACC615 0.47lb (0.2kg)



## ACC200, ACC205, ACC210, ACC255

Concrete Expansion Anchors

- Not recommended for concrete block applications (see ACC233, ACC234, ACC230, ACC243, ACC244, ACC240 for all types of concrete and cinder block applications)

ACC200: 2 anchors

ACC205: 3 anchors

ACC210: 4 anchors

ACC255: 50 anchors

Ship Weight: ACC200 0.2lb (0.09kg)

ACC205 0.2lb (0.09kg)

ACC210 1lb (0.45kg)

ACC255 2.09lb (0.94kg)



**IBA2(-W)***In-Wall Accessories Box*

1. Helps create clean and concealed installation by adding additional cable and power management space behind the display
2. Installs between 16" wood stud centers of dry-wall
3. Removeable outlet receptacle and cable management access plate
4. Cable ties for organized finish
5. Heavy cage cold rated steel construction

**Useable Space:** 13.10" x 9.6" x 3.76"  
(W x H x D) (333 x 244 x 96mm)

**Max Load:** 25lb (11.34kg)

**Ship Weight:** 5lb (2.27kg)  
**Color:** Gloss black or white

**IBA2AC(-W)** *In-Wall Accessories Box with 125V Duplex Power Receptacle*

1. Helps create clean and concealed installation by adding additional cable and power management space behind the display
2. Installs between 16" wood stud centers of dry-wall
3. Levitron SmartGrid tamper resistant duplex surge outlet and galvanized outlet box
4. Removeable outlet receptacle and cable management access plate
5. Cable ties for organized finish
6. Heavy cage cold rated steel construction

**Useable Space:** 13.10" x 9.6" x 3.76"  
(W x H x D) (333 x 244 x 96mm)

**Max Load:** 25lb (11.34kg)

**Ship Weight:** 5lb (2.27kg)  
**Color:** Gloss black or white

**IBA4-W** *In-wall Accessories Box with 125V Duplex Power Receptacle*

1. Inside-wall cable routing
2. Low profile design fits behind the thinnest mounts and flat panels
3. Sleek design makes outside cable covers unnecessary
4. Wing design eliminates the need for low voltage mounting brackets
5. Installation template included

**Overall Dimensions:** 3.22" x 4.88" x 2.17"  
(W x H x D) (82 x 124 x 55mm)

**Ship Weight:** 0.5lb (0.23kg)  
**Color:** White

**IBA3(-W)***In-Wall Accessories Box*

1. Helps create clean and concealed installation by adding additional cable and power management space behind the display
2. Installs between 16" wood stud centers of dry-wall
3. Removeable outlet receptacle and cable management access plate
4. Cable ties for organized finish
5. Heavy cage cold rated steel construction

**Useable Space:** 13.10" x 4.35" x 3.76"  
(W x H x D) (333 x 110 x 96mm)

**Max Load:** 25lb (11.34kg)

**Ship Weight:** 6.5lb (2.95kg)  
**Color:** Gloss black or white

**IBA3AC(-W)** *In-Wall Accessories Box with 125V Duplex Power Receptacle*

1. Helps create clean and concealed installation by adding additional cable and power management space behind the display
2. Installs between 16" wood stud centers of dry-wall
3. Levitron SmartGrid tamper resistant duplex surge outlet and galvanized outlet box
4. Removeable outlet receptacle and cable management access plate
5. Cable ties for organized finish
6. Heavy cage cold rated steel construction

**Useable Space:** 13.10" x 4.35" x 3.76"  
(W x H x D) (333 x 110 x 96mm)

**Max Load:** 25lb (11.34kg)

**IBA5-W** *In-wall Accessories Box with 125V Duplex Power Receptacle*

1. Duplex power receptacle with surge protection
2. Copper wiring device surgeblock protection
3. Inside wall cable routing
4. Wing design eliminates the need for low voltage mounting brackets
5. Low profile design fits behind the thinnest mounts and flat panels
6. Sleek design makes outside cable covers unnecessary

**Overall Dimensions:** 8.10" x 7.58" x 3.68"  
(W x H x D) (206 x 193 x 93mm)

**Ship Weight:** 2lb (0.91kg)  
**Color:** White



**ACC313**  
*Metal Shelf*

1. Metal shelf mounts directly to post of SR series flat panel cart
2. Installs above or below flat panel display
3. Holds AV or computer accessories
4. Designed with slots for safety belt (ACC316) to secure equipment

**Max Load:** 50lb (22kg)  
**Ship Weight:** 10.5lb (4.7kg)  
**Color:** Black



**ACC314**  
*Laptop Arm*

1. Attaches directly to post of SR series carts and SS series stands
2. Supports laptop
3. Vertical height and 180° swivel adjustability
4. Quick-release knob for easy height adjustment

**Max Load:** 10lb (4kg)  
**Ship Weight:** 10.3lb (4.6kg)  
**Color:** Black



**ACC317(-S), ACC318(-S)(GB)**  
*Tempered Glass Shelf*

1. Tempered glass shelf designed to hold AV components and accessories
2. Attaches directly to SS stands and SR carts

**Max Load:** 50lb (22kg)  
**Ship Weight:** 14.2lb (6.4kg)

**Color:**  
**ACC317(-S)** clear shelf, black or silver brackets  
**ACC318(-S)** tinted shelf, black or silver brackets  
**ACC318-GB** tinted shelf, high gloss black brackets



**ACC833**  
*Equipment Accessory Shelf*

1. Accommodates AV components
2. Mounts to 3.5" (89 mm) pole used in Peerless-AV® COL model pedestal displays
3. Can be mounted anywhere along the length of the column, facing any direction

**Max Load:** 40lb (18kg)  
**Ship Weight:** 10.1lb (4.6kg)  
**Color:** Black



**ACC324(-S)**  
*Corner Mount Shelf*

1. For use with CM850(-S), CM60(-S), CM50(-S)
2. Creates enclosed compartment when mounted at the bottom of corner mount
3. Top mounting provides open access to AV equipment

**Max Load:** 25lb (11kg)  
**Ship Weight:** 10lb (4.5kg)  
**Color:** Black or silver



**ACC315**  
*Base Shelf*

1. For SR series Flat Panel Display Cart
2. Additional storage space for PC or larger components
3. Designed with slots for safety belt (ACC316) to secure equipment

**Max Load:** 50lb (22kg)  
**Ship Weight:** 7.6lb (3.4kg)  
**Color:** Black



**ACC330**  
*AV Component Shelf for FPZ-640*

1. Attaches directly to Practico Flat Panel Stand
2. Holds AV components or accessories

**Max Load:** 20lb (9kg)  
**Ship Weight:** 4.4lb (2kg)  
**Color:** Black

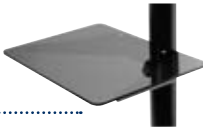

**ACC319**  
*Video Conferencing Shelf*

1. Mounts directly on top of SS stands and SR carts
2. Adjusts in height along with display

**Max Load:** 50lb (22kg)  
**Ship Weight:** 12.8lb (5.8kg)  
**Color:** Black



**ACC328**  
*Laptop Tray*

1. Simply attaches to LCT and LCW desktop and wall mounts for laptop usage
2. Designed with front edge to prevent laptop from sliding forward

**Max Load:** 17.5lb (7.9kg)  
**Ship Weight:** 5lb (2.26kg)  
**Color:** Black



**ACC325**  
*Accessory Shelf for FPZ-600*

1. Easily adjust along poles
2. Measures 21"W (533mm) x 19"D (482mm)

**Max Load:** 25lb (11.3kg)  
**Ship Weight:** 19.7lb (8.93kg)  
**Color:** Black



**ACC332**  
*Casters for FPZ-640*

1. Two locking casters ensures stability
2. Non-marking tread reduces scuff marks

**Max Load:** 110lb (50kg)  
**Ship Weight:** 3.30lb (1.5kg)  
**Color:** Silver



**ACC310**  
*Feet Accessory*

1. Four feet for stationary cart placement
2. Hard plastic base with steel casing

**Ship Weight:** 1lb (0.45kg)  
**Color:** Black



To verify mount compatibility with any flat panel display or projector model use MountFinder™ at [www.peerless-av.com](http://www.peerless-av.com)

## ACC320

### Electrical Outlet Strip with Cord Wrap

1. For use with SR Flat Panel Cart series
2. Includes outlet strip with three outlets
3. 20' (6096mm) long cord with hanger clamp and cord wrap

**Ship Weight:** 3lb (1.3kg)  
**Color:** Black



## ACC666

### Safety Belt

1. Heavy-duty black nylon safety belt
2. 13-foot endless loop ratchet tie-down
3. Recommended for use with mounts and carts

**Max Load:** 300lb (136kg)  
**Ship Weight:** 0.7lb (0.3kg)  
**Color:** Black



## ACC952 Above Display SUF Security Lock Accessory

1. Prevents flat panel display from being lifted up off of SUF Mount
2. Attaches to wall with theft resistant security screw
3. Two keyed alike padlocks prevent access to security screw

**Ship Weight:** 2lb (0.91kg)  
**Color:** Gloss Black



## ACC316

### Safety Belt

1. 8' (2438mm) belt to secure equipment to shelves with slots
2. Tear-resistant nylon

**Ship Weight:** 0.3lb (0.1kg)  
**Color:** Black



## ACC954 Theft resistant security kit for the PTM400 and PTM200

1. Theft Resistant Security Kit for the PTM400 and PTM200



## ACC111

### Safety Belt

1. Wraps around back of mount for additional roll out protection

**Max Load:** 150lb (68kg)  
**Ship Weight:** 1lb (0.5kg)  
**Color:** Black



## ACC918, ACC919, ACC925

### Security Fasteners for Wall Arms

1. Screen-side security fasteners for theft resistance

**ACC918:** for SA/SP730P Wall Arms  
**ACC919:** for SA/SP740P Wall Arms  
**ACC925:** for SA752PU, SA761PU, SA763PU & SA771PU Wall Arms

**Ship Weight:** **ACC918** 0.49lb (0.2kg)  
**ACC919** 0.49lb (0.2kg)  
**ACC925** 0.84lb (0.38kg)

**Color:** Black



## ACC502

### Security Fasteners

1. M10 penta-pin screws for Jumbo® Mounts (qty 10)
2. Kit includes installation tool

**Ship Weight:** 2lb (0.9kg)



## ACC930

### Fastener Kit for Speaker Mounts

1. Speaker mounts fastener kit for attaching Peerless-AV speaker mounts PSP2, PSP5 and SPK811 to corner mount

**Ship Weight:** 0.30lb (0.13kg)



## ACC016

### Oversized Roll-out Protectors

1. For use with Jumbo 2000® TV Mounts in place of regular side clamp
2. Grips TV instead of side speakers
3. 4.25" (107mm) of grip in front of monitor
4. Sold in pairs

**Ship Weight:** 1lb (.45kg)  
**Color:** Black



## ACC103, ACC104

### Bumper Guards

1. Provides protection by padding front corners of mount tray
2. Sold in pairs

**ACC103:** Fits all Jumbo® Mounts  
**ACC104:** Fits all Slimline® Mounts

**Ship Weight:** **ACC103** 0.2lb (.09kg)  
**ACC104** 0.1lb (.06kg)

**Color:** Black



## OP-ACC307 Fasteners for OSHPD

### compliant installations into cinder block walls

1. OP-ACC307 used when installing Peerless-AV OSHPD wall mounts to cinder block\*
2. Includes 10 threaded rods and fasteners for installing through wall

**OP-ACC204:** Concrete Fasteners  
**OP-ACC307:** Cinder Block Fasteners

**Ship Weight:** 1.5lb (0.68kg)

\* Only for smaller mounts that use 1/4" hardware





## FPEPM Pedestal Mount for Peerless-AV Protective Enclosures

1. Made of anti-corrosion materials for weather resistance
2. Mounts to concrete floor
3. 15° tilt

<b>FPEPM-05:</b>	5ft (1.52m)
<b>FPEPM-06:</b>	6ft (1.85m)
<b>FPEPM-07:</b>	7ft (2.13m)
<b>FPEPM-08:</b>	8ft (2.44m)

**Max Load:** 400lb (181kg)

<b>Ship Weight:</b>	<b>FPEPM-05</b>	120lb (54kg)
	<b>FPEPM-06</b>	130lb (58kg)
	<b>FPEPM-07</b>	140lb (63kg)
	<b>FPEPM-08</b>	150lb (68kg)

**Color:** Stone Gray



## FPECMC Concrete Ceiling Mount for Peerless-AV Protective Enclosures

1. Made of anti-corrosion materials for weather resistance
2. Mounts to concrete ceiling
3. 20° tilt

<b>FPECMC-01:</b>	1ft (0.30m)
<b>FPECMC-02:</b>	2ft (0.61m)
<b>FPECMC-03:</b>	3ft (0.91m)
<b>FPECMC-04:</b>	4ft (1.22m)

**Max Load:** 400lb (181kg)

<b>Ship Weight:</b>	<b>FPECMC-01</b>	64lb (29kg)
	<b>FPECMC-02</b>	66lb (30kg)
	<b>FPECMC-03</b>	68lb (31kg)
	<b>FPECMC-04</b>	70lb (32kg)

**Color:** Stone Gray



## FPECMI I-beam Mount for Peerless-AV Protective Enclosures

1. Made of anti-corrosion materials for weather resistance
2. Mounts to I-beam ceiling
3. 20° tilt

<b>FPECMI-01:</b>	1ft (0.30m)
<b>FPECMI-02:</b>	2ft (0.61m)
<b>FPECMI-03:</b>	3ft (0.91m)
<b>FPECMI-04:</b>	4ft (1.22m)

**Max Load:** 400lb (181kg)

<b>Ship Weight:</b>	<b>FPECMI-01</b>	67lb (30kg)
	<b>FPECMI-02</b>	69lb (31kg)
	<b>FPECMI-03</b>	71lb (32kg)
	<b>FPECMI-04</b>	73lb (33kg)

**Color:** Stone Gray



## FPEWM Tilt Wall Mount for Peerless-AV Protective Enclosures

1. Made of anti-corrosion materials for weather resistance
2. Mounts to wood stud wall
3. 20° tilt

**Max Load:** 400lb (181kg)

**Ship Weight:** 38lb (17kg)

**Color:** Stone Gray





MODEL	Page #
ACC002	194
ACC016	199
ACC050	194
ACC103	199
ACC104	199
ACC109	193
ACC111	199
ACC120	190
ACC170	195
ACC200	196
ACC205	196
ACC210	196
ACC215	196
ACC230	196
ACC233	196
ACC234	196
ACC240	196
ACC243	196
ACC244	196
ACC255	196
ACC309	166
ACC310	198
ACC313	198
ACC314	198
ACC315	198
ACC316	199
ACC317	198
ACC317-S	198
ACC318	198
ACC318GB	198
ACC318-S	198
ACC319	198
ACC320	199
ACC324	198
ACC324-S	198
ACC325	198
ACC328	198
ACC329	111
ACC330	198
ACC332	198
ACC415	196
ACC455	192
ACC502	199
ACC550	190
ACC556	190
ACC557	191
ACC558	191
ACC559	191
ACC560	190
ACC570	190
ACC570S	190
ACC570W	190
ACC575	193
ACC575-S	193
ACC575-W	193
ACC600	191
ACC604	195
ACC605	196
ACC610	196
ACC615	196
ACC625	196
ACC630	196
ACC640	194
ACC640-B	194
ACC640-W	194
ACC666	199
ACC800	193
ACC810	194
ACC830	194
ACC833	198

MODEL	Page #
ACC840	190
ACC845	190
ACC850	193
ACC850S	193
ACC852	194
ACC852S	194
ACC852W	194
ACC856	194
ACC856W	194
ACC912	190
ACC918	199
ACC919	199
ACC925	199
ACC930	199
ACC931	169
ACC931-S	169
ACC932	169
ACC932-S	169
ACC937	195
ACC951	169
ACC952	199
ACC953	189
ACC954	199
ACC955	189
ACC-DSV240	181
ACC-DSV329	181
ACC-DSV449	181
ACC-DSV503	181
ACC-DSV745	181
ACC-EXC	194
ACC-EXCS	194
ACC-EXCW	194
ACC-SB	189
ACCXT100	189
ACCXT101	189
ACCXT200	189
ACCXT201	189
ACCXT300	189
ACCXT301	189
ACCXT302	189
ACCXT400	189
ACCXT402	189
ADD012018	194
ADD018024	194
ADD0203	194
ADD0305	194
ADD0406	194
ADD0507	194
ADD0608	194
ADD0709	194
ADD0810	194
ADD0911	194
ADD101	194
ADD1012	194
ADD102	194
ADD103	194
ADD104	194
ADD105	194
ADD106	194
ADD107	194
ADD108	194
ADD109	194
ADD110	194
AEC006009	153, 193
AEC006009-S	153, 193
AEC006009-W	153, 193
AEC012018	153, 193
AEC012018-S	153, 193
AEC012018-W	153, 193
AEC018024	153, 193

MODEL	Page #
AEC018024-S	153, 193
AEC018024-W	153, 193
AEC0203	193
AEC0203-S	153, 193
AEC0203-W	153, 193
AEC0305	153, 193
AEC0305-S	153, 193
AEC0305-W	153, 193
AEC0406	153, 193
AEC0406-S	153, 193
AEC0406-W	153, 193
AEC0608	153, 193
AEC0608-S	153, 193
AEC0608-W	153, 193
AEC0810	153, 193
AEC0810-S	153, 193
AEC0810-W	153, 193
AEC1012	153, 193
AEC1012-S	153, 193
AEC1012-W	153, 193
ALU006009	153, 193
ALU006009-S	153, 193
ALU006009-W	153, 193
ALU0090012	153, 193
ALU0090012-S	153, 193
ALU0090012-W	153, 193
ALU0203	153, 193
ALU0203-S	153, 193
ALU0203-W	153, 193
ALU0305	153, 193
ALU0305-S	153, 193
ALU0305-W	153, 193
ALU0406	153, 193
ALU0406-S	153, 193
ALU0406-W	153, 193
ALU0507	153, 193
ALU0507-S	153, 193
ALU0507-W	153, 193
ALU0608	153, 193
ALU0608-S	153, 193
ALU0608-W	153, 193
ALU0810	153, 193
ALU0810-S	153, 193
ALU0810-W	153, 193
ALU1012	153, 193
ALU1012-S	153, 193
ALU1012-W	153, 193
ALU12018	153, 193
ALU12018-S	153, 193
ALU12018-W	153, 193
ALU18024	153, 193
ALU18024-S	153, 193
ALU18024-W	153, 193
AVL	165
AVM	164
CM50	90
CM50-S	90
CM60	90
CM60-S	90
CM850	9, 89
CM850-S	9, 89
CMJ300	190
CMJ310	190
CMJ450	192
CMJ453	192
CMJ455	192
CMJ470	190
CMJ471	190
CMJ480	190
CMJ490	190

To verify mount compatibility with any flat panel display or projector model use MountFinder™ at [www.peerless-av.com](http://www.peerless-av.com)



CALL: 630-375-5100  
800-865-2112



FAX: 630-820-8537  
800-359-6500



E-MAIL: [info@peerless-av.com](mailto:info@peerless-av.com)



ONLINE: [www.peerless-av.com](http://www.peerless-av.com)

**MODEL** **Page #**

CMJ500R1	192
CMR410	176
COL510P	124
COL610P	124
COL710P	124
COL810P	124
DCS200	191
DCS400	191
DCT100	191
DCT300	191
DCT500	191
DCT600	191
DCT700	191
DCT800	191
DCT900	191
DEB-CV05	159
DEB-CV10	159
DEB-CV15	159
DEB-CV20	159
DEB-HD10	157
DEB-HD15	157
DEB-HD20	157
DEB-RR10	160
DEB-RR15	160
DEB-RR20	160
DEW-HD05	157
DEW-JJ05	162
DEW-JR05	161
DEW-RR05	160
DS25	168
DS334	184
DS35	168
DS40	168
DS415	184
DS45	168
DS495	184
DS-ACC-LDCM	181
DST360	184
DST660	184
DST940	183
DST965	183
DS-VL-H018	181
DS-VL-H024	181
DS-VL-H036	181
DS-VL-H048	181
DS-VL-H060	181
DS-VL-H072	181
DS-VW560	177
DS-VW660	178
DS-VW765-LAND	179
DS-VW765-POR	180
DS-VWC560	182
DSX200	184
DSX750	184
ECMU-01-C	131
ECMU-01-C-S	131
ECMU-01-I	131
ECMU-01-I-S	131
ECMU-02-C	131
ECMU-02-C-S	131
ECMU-02-I	131
ECMU-02-I-S	131
ECMU-03-C	131
ECMU-03-C-S	131
ECMU-03-I	131
ECMU-03-I-S	131
ECMU-04-C	131
ECMU-04-C-S	131
ECMU-04-I	131
ECMU-04-I-S	131

**MODEL** **Page #**

EPMU-05	132
EPMU-05-S	132
EPMU-06	132
EPMU-06-S	132
EPMU-07	132
EPMU-07-S	132
EPMU-08	132
EPMU-08-S	132
EPT650	126
EPT650-S	126
ESA746PU	127
ESA746PU-S	127
ESA763PU	128
EWMU	130
EWMU-S	130
EXA	194
EXAS	194
EXAW	194
EXB	194
EXBS	194
EXBW	194
EXC	194
EXCS	194
EXCW	194
EXT002	153, 193
EXT002S	153, 193
EXT006	153, 193
EXT006S	153, 193
EXT018	153, 193
EXT018S	153, 193
EXT101	153, 193
EXT101S	153, 193
EXT102	153, 193
EXT102S	153, 193
EXT103	153, 193
EXT103	153, 193
EXT103S	153, 193
EXT103S	153, 193
EXT104	153, 193
EXT104S	153, 193
EXT105	153, 193
EXT105S	153, 193
EXT106	153, 193
EXT106S	153, 193
EXT107	153, 193
EXT107S	153, 193
EXT108	153, 193
EXT108S	153, 193
EXT109	153, 193
EXT109S	153, 193
EXT110	153, 193
EXT110S	153, 193
FLD-UNV	188
FLD-UNV-S	188
FPE42FH-S	129
FPE42F-S	129
FPE47FH-S	129
FPE47F-S	129
FPE55FH-S	129
FPE55F-S	129
FPECMC-01	200
FPECMC-02	200
FPECMC-03	200
FPECMC-04	200
FPECMI-01	200
FPECMI-02	200
FPECMI-03	200
FPECMI-04	200
FPEPM-05	200
FPEPM-06	200

**MODEL** **Page #**

FPEPM-07	200
FPEPM-08	200
FPEWM	200
FPS-1000	186
FPZ-600	10, 118
FPZ-640	10, 122
FPZ-646	10, 123
FPZ-655	10, 123
FPZ-670	10, 119
GC-PS3S	171
GC-UNV	170
GC-WII	171
GC-X360	171
GC-X360W	171
HF646-C52	185
HF646-C53	185
HF646-C54	185
HF646-C55	185
HF646-C56	185
HF646-C57	185
HF646-C58	185
HF646-C59	185
HF646-C60	185
HF646-C61	185
HF646-C62	185
HF646-C63	185
HLC-KIT	188
HLC-KIT-Q10	188
HP442	187
HP450	187
HP450-GB	187
HP450-S	187
HT642	185
HT642-002	185
IB40	87
IB40-S	87
IB40-W	87
IBA2	197
IBA2AC	197
IBA2AC-W	197
IBA2-W	197
IBA3	197
IBA3AC	197
IBA3AC-W	197
IBA3-W	197
IBA4-W	197
IBA5-W	197
IM740P	9, 85
IM740P-S	9, 85
IM760P	86
IM760P-S	86
IM760PU	9, 86
IM760PU-S	9, 86
IWB600-2SB	155
IWB600-UNIV	154
IWB600-WB	155
LCC-18	9, 94
LCC-18-C	9, 94
LCC-18-CS	9, 94
LCC-18S	9, 94
LCC-36	9, 94
LCC-36-C	9, 94
LCC-36-CS	9, 94
LCC-36S	9, 94
LCFS-100	10, 125
LCFS-100S	10, 125
LCH-100	9, 100
LCT100S	9, 102
LCT-101	9, 103
LCT-202	9, 104

To verify mount compatibility with any flat panel display or projector model use MountFinder™ at [www.peerless-av.com](http://www.peerless-av.com)



MODEL	Page #
LCT-203	9, 104
LCT420A	10, 108
LCT620A	10, 109
LCT620AD	10, 110
LCV-100	9, 101
LCW420A	10, 108
LCW620A	10, 109
LCW620AD	10, 110
LCZ-2F430B	9, 105
LCZ-3F419B	9, 106
LCZ-4F430B	9, 107
LCZ-4F4G30B	9, 107
LT-320	185
MIS735	195
MDJ700	96, 97
MDJ701	96, 97
MDJ710	96, 97
MDJ711	96, 97
MDJ720	96, 97
MDJ721	96, 97
MDJ760	96, 97
MM746PU	9, 23
MSA-101	172
MSA-101S	172
MSA-301	172
MSA-301S	172
ONE-TP	7, 80
OP-ACC307	199
PA730	8, 72
PA730-S	8, 72
PA735F	8, 73
PA735F-S	8, 73
PA740	9, 74
PA740-S	9, 74
PA746F	9, 75
PA746F-S	9, 75
PA760	9, 76
PAG-HDX	147
PAG-MU	146
PAG-UNV	146
PAG-UNV-HD	147
PAG-UNV-MU	146
PB-1	191
PC930A	9, 92
PC930A-S	9, 92
PC930A-W	9, 92
PC930B	9, 92
PC930B-S	9, 92
PC930B-W	9, 92
PC930C	9, 92
PC930C-S	9, 92
PC930C-W	9, 92
PC932A	9, 93
PC932A-S	9, 93
PC932A-W	9, 93
PC932B	9, 93
PC932B-S	9, 93
PC932B-W	9, 93
PC932C	9, 93
PC932C-S	9, 93
PC932C-W	9, 93
PCC	163
PCC-B	163
PCC-S	163
PE1120	151
PE1120-W	151
PF630	6, 61
PF632	6, 62
PF640	6, 63
PF660	6, 64

MODEL	Page #
PFT640	7, 69
PFT660	7, 69
PJF2-1	141
PJF2-MODELS	141
PJF2-UNV	141
PJF2-UNV-S	141
PLA50	81
PLA50-S	81
PLA50-UNL	9, 81
PLA50-UNLP	9, 81
PLA50-UNLP-GB	9, 81
PLA50-UNLP-GS	9, 81
PLA50-UNLP-S	9, 81
PLA50-UNL-S	9, 81
PLA60	82
PLA60-S	82
PLA60-UNL	9, 82
PLA60-UNLP	9, 82
PLA60-UNLP-GB	9, 82
PLA60-UNLP-GS	9, 82
PLA60-UNLP-S	9, 82
PLA60-UNL-S	9, 82
PLAV60	83
PLAV60-S	83
PLAV60-UNL	9, 83
PLAV60-UNLP	9, 83
PLAV60-UNLP-GB	9, 83
PLAV60-UNLP-GS	9, 83
PLAV60-UNLP-S	9, 83
PLAV60-UNL-S	9, 83
PLAV70	84
PLAV70-S	84
PLAV70-UNL	9, 84
PLAV70-UNLP	9, 84
PLAV70-UNLP-GB	9, 84
PLAV70-UNLP-GS	9, 84
PLAV70-UNLP-S	9, 84
PLAV70-UNL-S	9, 84
PLB-1	98
PLCK-1	91
PLCK-UNL	91
PLCM-1	95
PLCM-1CP	95
PLCM-2	95
PLCM-UN1	95
PLCM-UN1-CP	95
PLCM-UNL	95
PLCM-UNL-CP	9, 95
PLT-BLK	99
PP730	8, 70
PP730-S	8, 70
PP740	8, 71
PP740-S	8, 71
PPA	149
PPA-S	149
PPA-W	149
PPB	149
PPB-S	149
PPB-W	149
PPC	149
PPC-S	149
PPC-W	149
PPF	148
PPF-S	148
PPF-W	148
PRG-1	135
PRG-1-S	135
PRG-1-W	135
PRG-ALU0811	137
PRG-ALU1420	137

MODEL	Page #
PRG-ALU2026	137
PRG-EXA	136
PRG-EXA-S	136
PRG-EXA-W	136
PRG-EXB	136
PRG-EXB-S	136
PRG-EXB-W	136
PRG-EXC	136
PRG-EXC-S	136
PRG-EXC-W	136
PRG-KIT0811	137
PRG-KIT1420	137
PRG-KIT2026	137
PRG-MODELS	135
PRG-UNV	135
PRG-UNV-S	135
PRG-UNV-W	135
PRGS-ALU0811	143
PRGS-ALU1420	143
PRGS-ALU2026	143
PRGS-KIT0811	143
PRGS-KIT1420	143
PRGS-KIT2026	143
PRGS-UNV	142
PRS-1	138
PRS-1-S	138
PRS-1-W	138
PRS-EXA	139
PRS-EXA-S	139
PRS-EXA-W	139
PRS-EXB	139
PRS-EXB-S	139
PRS-EXB-W	139
PRS-EXC	139
PRS-EXC-S	139
PRS-EXC-W	139
PRS-ALU0811	140
PRS-ALU1420	140
PRS-ALU2026	140
PRS-KIT0811	140
PRS-KIT1420	140
PRS-KIT2026	140
PRS-MODELS	138
PRS-UNV	138
PRS-UNV-S	138
PRS-UNV-W	138
PRSS-ALU0811	145
PRSS-ALU1420	145
PRSS-ALU2026	145
PRSS-KIT0811	145
PRSS-KIT1420	145
PRSS-KIT2026	145
PRSS-UNV	144
PS-1	77
PS-2	77
PS200	167
PSM-UNV	150
PSM-UNV-S	150
PSM-UNV-W	150
PSMU-PRS	150
PSMU-PRS-S	150
PSMU-PRS-W	150
PSP2	173
PSP2-W	173
PSP5	173
PSP5-W	173
PSTA-600	153
PSTA-1200	153
PSTA-1600	153
PSTK-600	153

To verify mount compatibility with any flat panel display or projector model use MountFinder™ at [www.peerless-av.com](http://www.peerless-av.com)



CALL: 630-375-5100  
800-865-2112



FAX: 630-820-8537  
800-359-6500



E-MAIL:  
[info@peerless-av.com](mailto:info@peerless-av.com)



ONLINE:  
[www.peerless-av.com](http://www.peerless-av.com)

**MODEL** **Page #**

PSTK-1200.....	153
PSTK-1600.....	153
PT-420A.....	185
PT630.....	7, 65
PT632.....	7, 66
PT640.....	7, 67
PT660.....	7, 68
PTM200.....	10, 78
PTM200-S.....	10, 78
PTM400.....	10, 79
PTM400S.....	10, 79
PTM400S-W.....	10, 79
PTM400-W.....	10, 79
PWA-14.....	195
PWA-14S.....	195
PWA-14W.....	195
RMI1.....	88
SA730P.....	8, 51
SA730P-S.....	8, 51
SA735P.....	8, 52
SA735P-S.....	8, 52
SA740P.....	8, 53
SA740P-S.....	8, 53
SA746PU.....	8, 54
SA752P.....	8, 55
SA752PU.....	8, 55
SA761P.....	8, 56
SA761PU.....	8, 56
SA763PU.....	8, 57
SA771P.....	8, 58
SA771PU.....	8, 58
SAX755PU.....	8, 30
SAX762PU.....	8, 31
SAX772PU.....	8, 32
SC550.....	10, 112
SC550GL.....	10, 112
SC551GL.....	10, 113
SC560DPB.....	10, 115
SC560DPS.....	10, 115
SC560FK.....	10, 120
SF16D.....	59
SF24D.....	59
SF630.....	6, 33
SF630P.....	6, 33
SF630P-S.....	6, 33
SF630-S.....	6, 33
SF632.....	6, 34
SF632P.....	6, 34
SF632P-S.....	6, 34
SF632-S.....	6, 34
SF640.....	6, 35
SF640P.....	6, 35
SF640P-S.....	6, 35
SF640-S.....	6, 35
SF650.....	6, 36
SF650P.....	6, 36
SF650P-S.....	6, 36
SF650-S.....	6, 36
SF660.....	6, 37
SF660P.....	6, 37
SF660P-S.....	6, 37
SF660-S.....	6, 37
SF670.....	6, 38
SF670P.....	6, 38
SF670P-S.....	6, 38
SF670-S.....	6, 38
SF680.....	6, 39
SF680P.....	6, 39
SF680P-S.....	6, 39
SF680-S.....	6, 39

**MODEL** **Page #**

SFX645.....	6, 24
SFX645P.....	6, 24
SFX650.....	6, 25
SFX650P.....	6, 25
SFX660.....	6, 26
SFX660P.....	6, 26
SGLB01.....	121
SGLS01.....	121
SLW-HDRU05.....	158
SLW-HDRZ05.....	158
SP730P.....	8, 48
SP730P-S.....	8, 48
SP735P.....	8, 48
SP735P-S.....	8, 48
SP740P.....	8, 49
SP740P-S.....	8, 49
SP746PU.....	8, 49
SP850.....	50
SP850P.....	50
SP850-S.....	50
SP850-S.....	50
SP850-UNL.....	8, 50
SP850-UNLP.....	8, 50
SP850-UNLP-GB.....	8, 50
SP850-UNLP-GS.....	8, 50
SP850-UNLP-S.....	8, 50
SP850-UNL-S.....	8, 50
SPK811.....	174
SPK811W.....	174
SPK815.....	175
SR1G.....	114
SR1M.....	114
SR560G.....	10, 114
SR560M.....	10, 114
SS550P.....	10, 121
SS550P-S.....	10, 121
SS560DPB.....	10, 117
SS560DPB-1.....	115
SS560DPS.....	10, 117
SS560DPS-1.....	115
SS560F.....	10, 116
SS560FK.....	10, 120
SS560G.....	10, 114
SS560M.....	10, 114
ST16D.....	60
ST24D.....	60
ST630.....	7, 40
ST630P.....	7, 40
ST630P-S.....	7, 40
ST630-S.....	7, 40
ST632.....	7, 41
ST632P.....	7, 41
ST632P-S.....	7, 41
ST632-S.....	7, 41
ST635.....	7, 42
ST635P.....	7, 42
ST635P-S.....	7, 42
ST635-S.....	7, 42
ST640.....	7, 43
ST640P.....	7, 43
ST640P-S.....	7, 43
ST640-S.....	7, 43
ST650.....	7, 44
ST650P.....	7, 44
ST650P-S.....	7, 44
ST650-S.....	7, 44
ST660.....	7, 45
ST660P.....	7, 45
ST660P-S.....	7, 45
ST660-S.....	7, 45

**MODEL** **Page #**

ST670.....	7, 46
ST670P.....	7, 46
ST670P-S.....	7, 46
ST670-S.....	7, 46
ST680.....	7, 47
ST680P.....	7, 47
ST680P-S.....	7, 47
ST680-S.....	7, 47
STX645.....	7, 27
STX645L.....	7, 27
STX645P.....	7, 27
STX650.....	7, 28
STX650L.....	7, 28
STX650P.....	7, 28
STX660.....	7, 29
STX660L.....	7, 29
STX660P.....	7, 29
SUA737.....	8, 20
SUA746PU.....	8, 20
SUA751PU.....	8, 21
SUA765PU.....	8, 22
SUF640P.....	6, 11
SUF641.....	6, 14
SUF650P.....	6, 12
SUF651.....	6, 15
SUF660P.....	6, 13
SUF661.....	6, 16
SUT632P.....	7, 17
SUT645P.....	7, 18
SUT660P.....	7, 19
VPM25-J.....	168
VPM25-W.....	168
VPM35-J.....	168
VPM35-S.....	168
VPM40-J.....	168
VPM40-JS.....	168
VPM40-S.....	168
VPM40-W.....	168
VPM45-J.....	168
VPM45-S.....	168
WBK100.....	195
WBK100-W.....	195
WMJ018.....	195
WMJ022.....	195
WMJ025H.....	195
WSP415.....	195
WSP425.....	196
WSP445.....	196
WSP445W.....	196
WSP450.....	196
WSP460.....	196
WSP470.....	196
WSP700.....	195
WSP701.....	195
WSP716.....	195
WSP716GB.....	195
WSP716GS.....	195
WSP716S.....	195
WSP716W.....	195
WSP724.....	195
WSP724GB.....	195
WSP724GS.....	195
WSP724S.....	195
WSP724W.....	195
WSP756.....	195
WSP816.....	196
WSP820.....	196
WSP824.....	196

To verify mount compatibility with any flat panel display or projector model use MountFinder™ at [www.peerless-av.com](http://www.peerless-av.com)



# Terms & Conditions

## TERMS OF PAYMENT

Payment should be made according to the payment terms referenced on the invoice of each shipment. Each shipment shall be considered a separate and independent transaction, and payment, therefore, shall be made accordingly. Please include our invoice number with your payment.

## PRICES

Prices are subject to change without prior notice. Orders are accepted at pricing in effect on the date of shipment. Customers requiring price guarantees for a specific period of time must submit a written list of accounts on which proposals have been made, giving the date of the proposal, the customer's name, items quoted and the expected purchase date.

## SPECIFICATIONS

Peerless-AV is constantly striving to develop new products and improve existing ones. We therefore reserve the right to change or revise product designs, product specifications, and model numbers without notice.

## DELIVERY

Prices are FOB warehouse, Aurora, Illinois, or point of shipment. All transportation costs and risk of freight damage are the obligation of the buyer. Any claims for shortages or damages, whether concealed or otherwise, must be filed with the common freight carrier. All promises of delivery are made in good faith, and Peerless-AV will make every reasonable effort to see that they are fulfilled. However, if we are unable to meet scheduled delivery dates due to factors beyond our control, such as fires, strikes, government directive, or failure of our suppliers to meet their promises, we shall not be liable for consequential or special damage. Refused shipments will automatically receive a 25% restocking fee plus the cost of the return freight.

## RETURN OF GOODS

For returns please call Returns Coordinator at: 630-375-5100, 7:00AM to 7:00PM CST or email us at [returns@peerless-av.com](mailto:returns@peerless-av.com)

Return of goods for repair, warranty claims, credit or any other reason will not be accepted without a RETURN MATERIAL AUTHORIZATION (RMA) number. Such number can be obtained from the Peerless Customer Service Team upon request, provided that all of the necessary information is available regarding the proposed return. Defective goods will be replaced or credited, at the customer's option, at no additional charge.

A minimum 25% restocking charge applies to all non-defective products returned for credit within the first 30 days after purchase. Thereafter, a larger restocking charge will be applied based upon the date of original shipment. Products will not be accepted for return 120 days after their original ship date. Custom product, specially produced or not normally carried in inventory, will not be accepted for return under any circumstances. Also, any obsolete products will not be accepted for return under any circumstances. All items to be returned must be sent back to us via pre-paid freight, with the RETURN MATERIAL AUTHORIZATION (RMA) number clearly marked on the carton and noted on the packing slip. No freight collect shipments will be accepted.

If a customer orders the wrong product by mistake, it may be returned with a reduced restocking charge of 10% if ALL of the following conditions are met; the incorrectly ordered products are returned within 30 days of receipt of shipment, the customer must pay freight to return the product, the product must be received in the original packaging and in like-new condition, the customer must immediately place a replacement order of equal or greater value than that of the order being returned. If and only if all of these conditions are met, at the discretion of Peerless, may a customer receive the reduced 10% restocking charge.

It is the purchaser's responsibility to provide adequate packaging to protect the product being returned. Peerless reserves the right to accept or reject the returned product subject to an inspection upon receipt. Products that are returned severely damaged may be rejected and therefore will not qualify for any type of return credit. The following chart defines the minimum restocking charge that will be applied for goods accepted for return by Peerless. It does not include any additional charges that may apply for damaged products or those needing rework.

<u>Days since shipping</u>	<u>Restocking Charge</u>
0-30	25%
31-59	35%
60-119	50%
120+	Returns not accepted

## SPECIAL ORDERS

We are ready to work with you to tailor our products for your special equipment mounting needs. In most cases, we can provide special paint, engineering, and manufacturing processes. Standard product colors are indicated within the catalog. Product (not including fasteners) can be ordered in other paint choices including black, white, silver, and gray for a surcharge. Charges for other custom paint colors and product design/manufacturing modifications will be quoted on an individual basis. Custom painted or manufactured product CANNOT BE RETURNED. Contact the Customer Care Team for more information.

## LIMITED WARRANTY

Peerless-AV warrants its products, under normal use, to be free from defects in material and workmanship for a period of five years from the date of purchase. Peerless-AV, at its sole discretion, will repair or replace such defective equipment free of charge provided the products are returned prepaid to Peerless-AV. Thereafter, repairs will be made at established factory prices. Unauthorized service or repairs by anyone other than authorized Peerless-AV personnel renders this Warranty void and releases Peerless-AV from any further responsibility or obligation. Any damage caused by failure to observe proper packing or to observe instructions for installation, by accident or in transit or elsewhere will not be covered by the Warranty. This Warranty is in lieu of all other Warranties expressed or implied, and no one is authorized to assume any liability on behalf of Peerless-AV or impose any obligation on it in connection with the sale of any product other than as outlined above. In no event will responsibility be assumed or implied for consequential damages arising from the theft of any product secured by a Peerless-AV security device, by delay of installation, interrupted operation or other causes.

## FREIGHT OPTIONS

**Freight Program** The Peerless-AV NO SUPPRISES™ FREIGHT PROGRAM takes the guesswork out of calculating your total costs. Freight costs are based on a percentage of the total order value. The Peerless-AV Freight Program only applies to dock deliveries. For further information or to obtain a freight quote, please contact Customer Care or your Peerless-AV Sales Representative.

**Collect** Have your order billed to the receiver on the receiver's freight account.

**Third Party Bill** Have your order billed to an approved third party's freight account.



CALL: 630-375-5100  
800-865-2112



FAX: 630-820-8537  
800-359-6500



E-MAIL:  
[info@peerless-av.com](mailto:info@peerless-av.com)



ONLINE:  
[www.peerless-av.com](http://www.peerless-av.com)

**peerless-AV**

Visit us at [www.peerless-av.com](http://www.peerless-av.com)

Follow us on



Scan this QR code\* to use our interactive catalog on your Smartphone or tablet, or visit [ecatalog.peerless-av.com](http://ecatalog.peerless-av.com).

*\*Download a free QR Reader at your devices' app store.*

LIT-CAT2012, rev. 12, 01-01-2012

#### Peerless-AV

2300 White Oak Circle  
Aurora, IL 60502 USA  
Toll Free: 800-865-2112  
P: 630-375-5100  
F: 800-359-6500  
[sales@peerless-av.com](mailto:sales@peerless-av.com)

#### Peerless-AV Europe

Unit 3 Watford Interchange  
Colonial Way, Watford  
Herts, WD24 4WP  
United Kingdom  
P: +44(0) 1923 205600  
F: +44(0) 1923 205601

#### Peerless-AV de México

Ave de las Industrias 413  
Parque Industrial Escobedo  
Escobedo, N. L.,  
Mexico 66050  
P: +52 (81) 8383-8300  
F: +52 (81) 8384-8360

